



Jergens®

MANUFACTURING EFFICIENCY

 WWW.JERGENSINC.COM/LIFTING





Rugged American Made Quality

Jergens hoist rings are made the way they should be: right here in the USA, starting with domestically-produced, certified alloy steel. Choose Jergens and get tough, dependable, American-made quality every time. Period.

Quality Control for Safety's Sake

Our quality control procedures define the entire manufacturing process and provide complete traceability from raw materials, tested in our metallurgical lab, to finished product. Our state-of-the-art, 110,000 square foot facility is ISO 9001:2008 rated, and our center and side pull hoist rings are CE certified. Finally, all hoist rings conform to: (OSHA) 29 CFR 1918, ANSI B30-26, MIL-STD-1365C, MIL-STD-209K.

Jergens, Inc. is a proud supplier to leading companies in the following industries:

- Transportation
- Military/Aviation
- Manufacturing
- Metalworking
- Material Handling
- Recreation
- Entertainment

View our Quality Certifications at

www.jergensinc.com/site/showcase_lifting/quality.html



LIFTING SOLUTIONS

Lifting Solutions

Center Pull Style	8-9
Envirolox™ Protective Finish	15
Eye Bolts	21
Eye Nuts.....	20
Forged Center Pull	6-7
Forged Center Pull Stainless Steel	5
Kwik-Lok® Lifting Pin	16-17
Hold Down Clips	15
Installation Information	3
LIFT ID™	4
Pivoting Lift Rings	20
Quality Standard Information	23-24
Shoulder Eyebolts	21
Side-Pull Style	10-11
Side Swivel.....	14
SP 2000 Side-Pull Style.....	12-13
Swivel Eyebolts	18-19



Engineer The Lift!!

- Jergens recommends the use of swiveling and pivoting hoist rings.
- Conventional eye bolts should be used for straight vertical lifts only.
- Are you using the proper hoist ring for the application?
- Is the hoist ring free to swivel and pivot? Any movement restrictions?
- Are lifting hole(s) in the proper location?
- Do you have the correct hole size for the hardware - safe lift capacity?
- Are the holes tapped deep enough to assure full thread engagement? (See figure #3 on Installation Information; page 3.)
- Recommended thread depth:
 - Steel – 1-1/2 times the bolt diameter (min.)
 - Aluminum – 2 times the bolt diameter (min.)
- **RULE OF THUMB, IF IN DOUBT – DON'T!!!**

Applied Load Changes With Sling Angle

Jergens swivelling hoist rings are designed and rated to be pulled at any angle at the rated load. However, the applied load on a multipoint lift will increase if the sling angle is less than 90°. So be sure to consider the sling angle when selecting lifting equipment. See illustration below.

Sample Calculation:

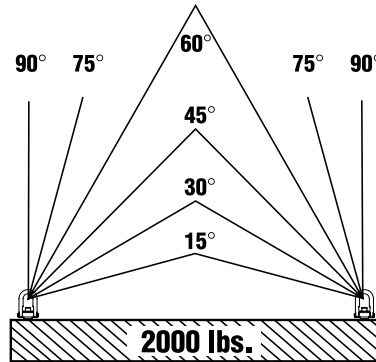
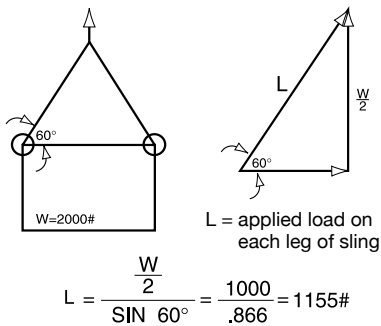

Sling Angle (Degrees)	Applied Load (Pounds)
90	1000
75	1040
60	1155
45	1410
30	2000
15	3860

DO'S

1. Observe working load limitations (be especially careful with eyebolts used for angle lifts – see sling angle chart).
2. Visually inspect hoist ring prior to use.
3. Fully tighten hoist ring to recommended torque. Full thread engagement is required (no space between swivel bushing and lift).
4. Assure proper thread depth - do not shim.
5. Make sure hoist rings have free travel - it must swivel and pivot without restrictions.
6. When installing in soft metal, such as aluminum, the minimum effective thread engagement should be two times the diameter of the thread (1-1/2 times bolt diameter – steel).

DON'TS

1. Never pull a Center Pull Style hoist ring bar from the side.
2. Never use an oversized hook in eyebolts or hoist rings (See figure #1 on Installation Information; page 3).
3. Never use excessive sling angle.
4. Never steam clean or degrease hoist rings (could cause rusting and binding).
5. Never apply shock loads.
6. Never allow the side of a hoist ring to make contact with the lift. (See figure #2 on Installation Information; page 3.)

Installation Information

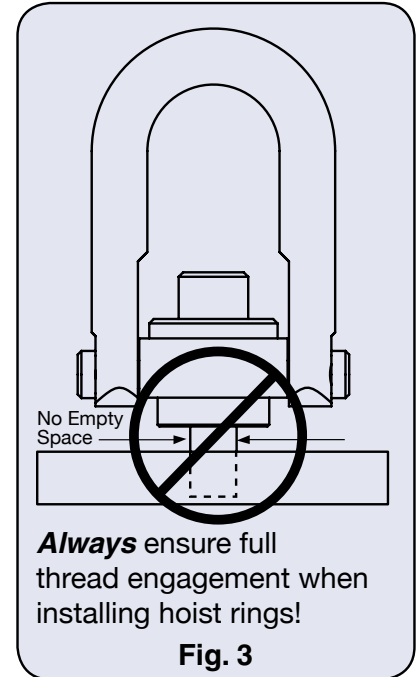
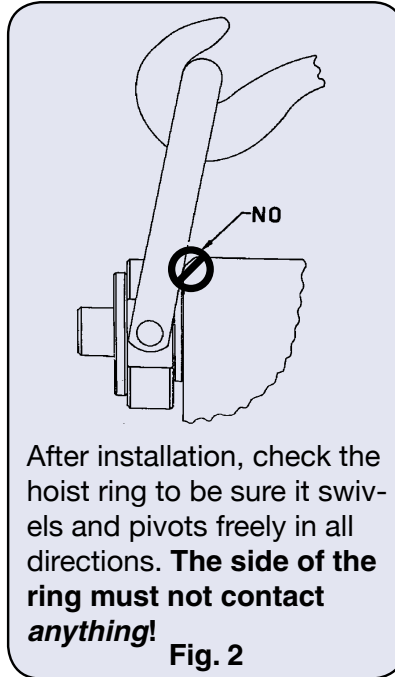
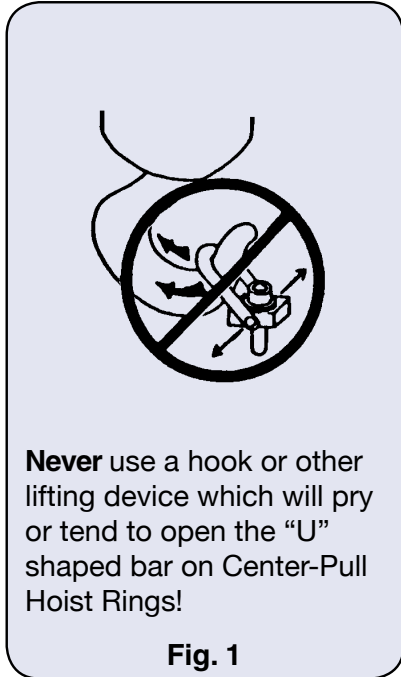

Select the proper Hoist Ring for the job. Do not attempt to apply more than the rated load capacity. *The load capacity is marked on the Hoist Ring.*

Drill and tap the workpiece so that the hoist ring bolt is installed perpendicular to the surface of the workpiece. Countersink the tapped hole to prevent “swelling” of the top thread when the hoist ring bolt is torqued. The workpiece surface must be flat, providing complete contact for the hoist ring bushing.

Do not use spacers between the hoist ring bushing and the workpiece surface.

When installing in soft metal, such as aluminum, the minimum effective thread engagement should be two times the diameter of the thread. When installing in steel, thread engagement should be 1-1/2 times the thread diameter.

Always *tighten the bolt to the proper torque value*, which is stamped on the Hoist Ring.

Loosening of the *bolt* may develop during use. *Re-tightening to the required torque must be done whenever the bolt loosens.* The proper tightening torque is stamped on the Hoist Ring.

When lifting, apply force gradually. **DO NOT APPLY SHOCK LOADS.**

For through-hole applications, be sure that nut/washer are the same quality grade as the Hoist Ring.

Periodic visual inspection and pull testing is recommended as damage can occur from improper usage.

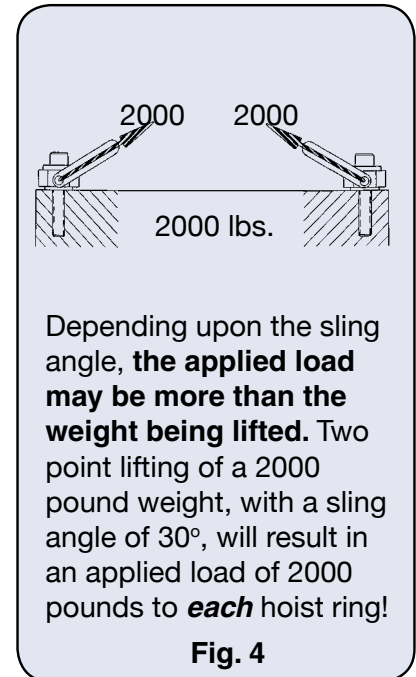



Lift ID™ Automated Inspection and Compliance System



Kwik-Lok® Lifting Pin

The rugged RFID tag is engineered for service even in the most demanding environments. **Lift ID™** is available with all Jergens lifting products, including **Kwik-Lok®** Lifting Pins.

Exclusively from Jergens, **Lift ID™** combines the power of RFID, the ease of mobile computers and the convenience of the Internet to automate the entire tracking and reporting process. This two part system combines rugged hardware and powerful software to simplify your workplace safety compliance program.

The embedded RFID tags on Jergens' lifting products provide a quick and efficient way to identify and track equipment in the field. The RFID tag is scanned and **Lift ID™** Software accesses our secure website to track the manufacturing and test data for that particular hoist ring. Safety testing, repair histories, inspection certificates and more are immediately accessible from anywhere using web-based administration.

Lift ID™ is available with all Jergens lifting products.

Simply add an "F" to the end of the part number when ordering. Example: 23414F

Easy identification using RFID technology

Perform one-click visual inspections

Perform non-destructive testing (proof tests, magnetic particle)

Generate electronic inspection certificates from the Web

Allow your customers online access to see the audit trail and traceability

Automatic product registration

Use handheld client online and offline

Access to the safety network

Fully hosted solution with phone, Web and e-mail support packages

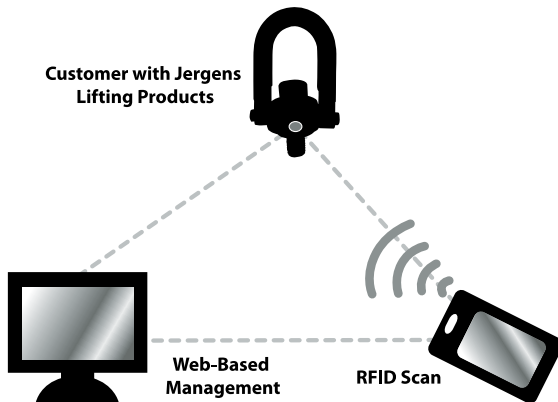

- ✓ Compatible with N4 Systems' FieldID Inspection and Safety Compliance Suite
- ✓ Compliant with the ISO 15693 air interface standard



LIFT ID™

AUTOMATED INSPECTION AND COMPLIANCE SYSTEM

Forged Center Pull - Stainless Steel



Our new Forged Center Pull Hoist Ring integrates a solid center brace lift bail into our most popular style product. This design eliminates the possibility of spreading the lift ring in misapplications. Forged hoist rings are ideal for OEM and industrial use.

- Material: 17-4PH
- Full (over center) 360° swivel and 180° pivot action
- Capacities up to 5,000 lbs.
- Inch and metric
- 5:1 strength factor
- Same strength/load capacity as steel
- Maximum operating pressure 800°F Intermittent, 600°F continuous
- Made in U.S.A.
- 3D Solid Models available in multiple formats from www.jergensinc.com

U.S. Patent No. 6,652,012



To add Lift ID™ to Hoist Ring
Add "F" to the end of the part
number Example: 23414F

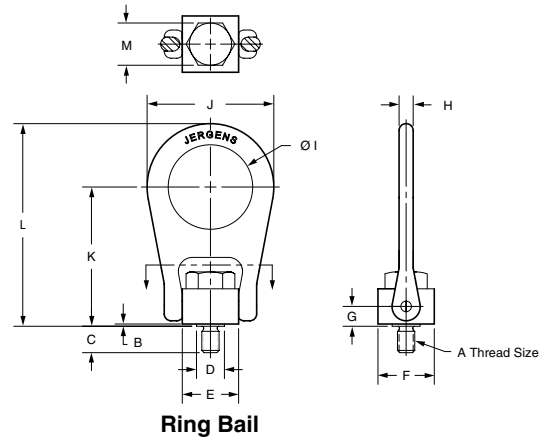

Inch

Part Number	Load Capacity (lbs)	Thread Size A	B	C	D	E	F	G	H	I	J	K	L	Hex Size M	Torque (ft.lbs)	Weight (lbs)
23906-SS	800	5/16-18	3/64	15/32	1/2	1	1	11/32	1/4	1 1/2	2 1/4	2 15/32	3 19/32	3/4	7	0.6
23907-SS	800	5/16-18	3/64	5/8	1/2	1	1	11/32	1/4	1 1/2	2 1/4	2 15/32	3 19/32	3/4	7	0.6
23908-SS	1000	3/8-16	3/64	9/16	1/2	1	1	11/32	1/4	1 1/2	2 1/4	2 15/32	3 19/32	3/4	12	0.6
23909-SS	1000	3/8-16	3/64	3/4	1/2	1	1	11/32	1/4	1 1/2	2 1/4	2 15/32	3 19/32	3/4	12	0.6
23910-SS	2500	1/2-13	1/16	11/16	1	2	1 1/2	9/16	3/4	3	4 7/16	4	6 3/8	1 1/4	28	3.6
23911-SS	2500	1/2-13	1/16	1	1	2	1 1/2	9/16	3/4	3	4 7/16	4	6 3/8	1 1/4	28	3.6
23914-SS	4000	5/8-11	1/16	15/16	1	2	1 1/2	9/16	3/4	3	4 7/16	4	6 3/8	1 1/4	60	3.6
23915-SS	4000	5/8-11	1/16	1 1/4	1	2	1 1/2	9/16	3/4	3	4 7/16	4	6 3/8	1 1/4	60	3.6
23917-SS	5000	3/4-10	1/16	1 1/8	1	2	1 1/2	9/16	3/4	3	4 7/16	4	6 3/8	1 1/4	100	3.6
23918-SS	5000	3/4-10	1/16	1 1/2	1	2	1 1/2	9/16	3/4	3	4 7/16	4	6 3/8	1 1/4	100	3.6

Metric

Part Number	Load Capacity (kg)	Thread Size A	B	C	D	E	F	G	H	I	J	K	L	Hex Size M	Torque (N•m)	Weight (kg)
23956-SS	400	M8 X 1.25	1.2	12	12.7	25.4	25.4	8.7	6.3	38.1	57.2	62.7	91.3	19	10	0.27
23958-SS	450	M10 X 1.5	1.2	15	12.7	25.4	25.4	8.7	6.3	38.1	57.2	62.7	91.3	19	17	0.27
23962-SS	1050	M12 X 1.75	1.6	18	25.4	50.8	38.1	14.3	19	76.2	112.7	101.6	161.9	32	37	1.64
23965-SS	1900	M16 X 2.0	1.6	24	25.4	50.8	38.1	14.3	19	76.2	112.7	101.6	161.9	32	80	1.64
23968-SS	2150	M20 X 2.5	1.6	30	25.4	50.8	38.1	14.3	19	76.2	112.7	101.6	161.9	32	134	1.7



Forged Center Pull



Our new Forged Center Pull Hoist Ring integrates a solid center brace lift bail into our most popular style product. This design eliminates the possibility of spreading the lift ring in misapplications. Forged hoist rings are ideal for OEM and industrial use.

- Full (over center) 360° swivel and 180° pivot action
- Capacities up to 30,000 lbs.
- Inch and metric
- 5:1 strength factor-alloy steel
- Available in 17-4PH Stainless Steel (up to 5,000lbs/2,150kgs.) See page 5.
- Made in U.S.A.
- 3D Solid Models available in multiple formats from www.jergensinc.com

U.S. Patent No. 6,652,012



To add Lift ID™ to Hoist Ring
Add "F" to the end of the part
number Example: 23414F

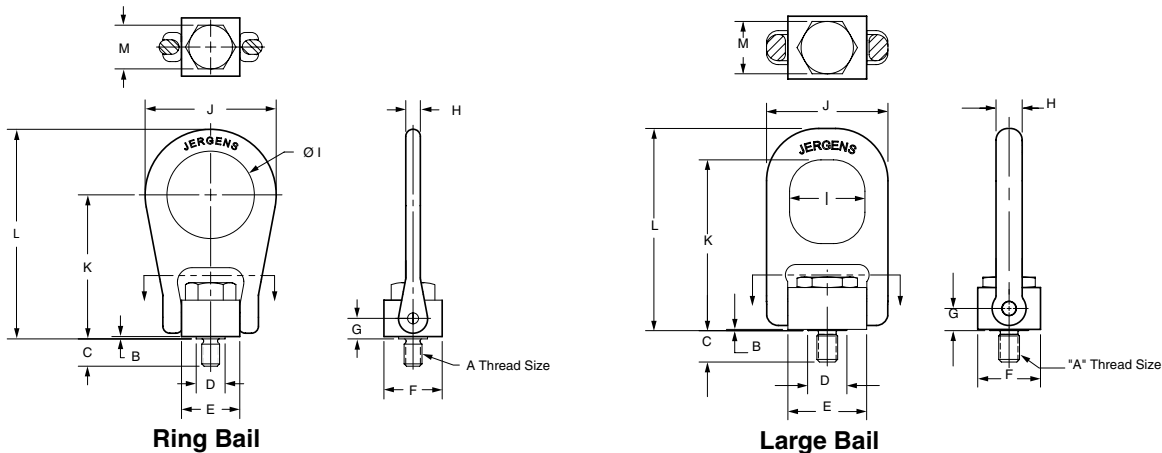

Ring Bail

Large Bail

Inch

Part Number	Load Capacity (lbs)	Thread Size A	B	C	D	E	F	G	H	I	J	K	L	Hex Size M	Torque (ft.lbs)	Weight (lbs)
23906	800	5/16-18	3/64	15/32	1/2	1	1	11/32	1/4	1 1/2	2 1/4	2 15/32	3 19/32	3/4	7	0.6
23907	800	5/16-18	3/64	5/8	1/2	1	1	11/32	1/4	1 1/2	2 1/4	2 15/32	3 19/32	3/4	7	0.6
23908	1000	3/8-16	3/64	9/16	1/2	1	1	11/32	1/4	1 1/2	2 1/4	2 15/32	3 19/32	3/4	12	0.6
23909	1000	3/8-16	3/64	3/4	1/2	1	1	11/32	1/4	1 1/2	2 1/4	2 15/32	3 19/32	3/4	12	0.6
23910	2500	1/2-13	1/16	11/16	1	2	1 1/2	9/16	3/4	3	4 7/16	4	6 3/8	1 1/4	28	3.6
23911	2500	1/2-13	1/16	1	1	2	1 1/2	9/16	3/4	3	4 7/16	4	6 3/8	1 1/4	28	3.6
23914	4000	5/8-11	1/16	15/16	1	2	1 1/2	9/16	3/4	3	4 7/16	4	6 3/8	1 1/4	60	3.6
23915	4000	5/8-11	1/16	1 1/4	1	2	1 1/2	9/16	3/4	3	4 7/16	4	6 3/8	1 1/4	60	3.6
23917	5000	3/4-10	1/16	1 1/8	1	2	1 1/2	9/16	3/4	3	4 7/16	4	6 3/8	1 1/4	100	3.6
23918	5000	3/4-10	1/16	1 1/2	1	2	1 1/2	9/16	3/4	3	4 7/16	4	6 3/8	1 1/4	100	3.6
23926	10000	1-8	1/16	1 1/2	1 7/8	3 25/32	3	1 1/16	1 1/4	3 19/32	5 13/16	8 5/32	9 21/32	2 1/2	230	15.7
23927	10000	1-8	1/16	2	1 7/8	3 25/32	3	1 1/16	1 1/4	3 19/32	5 13/16	8 5/32	9 21/32	2 1/2	230	15.9
23929	15000	1 1/4-7	1/16	1 7/8	1 7/8	3 25/32	3	1 1/16	1 1/4	3 19/32	5 13/16	8 5/32	9 21/32	2 1/2	470	16.0
23930	15000	1 1/4-7	1/16	2 1/2	1 7/8	3 25/32	3	1 1/16	1 1/4	3 19/32	5 13/16	8 5/32	9 21/32	2 1/2	470	16.2
23933	24000	1 1/2-6	7/64	2 1/4	2 1/2	4 7/8	4 1/2	1 7/16	1 3/4	4 1/2	7 23/32	11 7/16	13 27/32	3 1/4	800	42.3
23934	24000	1 1/2-6	7/64	3	2 1/2	4 7/8	4 1/2	1 7/16	1 3/4	4 1/2	7 23/32	11 7/16	13 27/32	3 1/4	800	42.7
23935	30000	2-4 1/2	7/64	3	2 1/2	4 7/8	4 1/2	1 7/16	1 3/4	4 1/2	7 23/32	11 7/16	13 27/32	3 1/4	800	43.8
23936	30000	2-4 1/2	7/64	4	2 1/2	4 7/8	4 1/2	1 7/16	1 3/4	4 1/2	7 23/32	11 7/16	13 27/32	3 1/4	800	44.7



Ring Bail

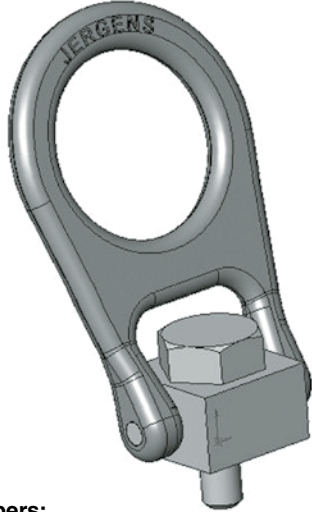

Ring Bail

Part Numbers:

23906 thru 23918 (Inch)
23956 thru 23968 (Metric)

Large Bail

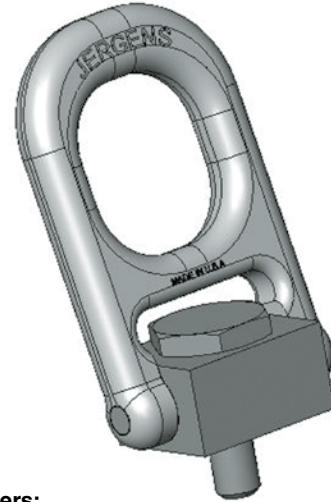

Large Bail

Part Numbers:

23926 thru 23936 (Inch)
23974 thru 23987 (Metric)

- Replace Stationary Eyebolt
- Lifting Tooling Columns & Large Fixtures
- OEM Applications
- Lifting Die & Molds



To add Lift ID™ to Hoist Ring
Add "F" to the end of the part
number Example: 23414F



Metric

Part Number	Load Capacity (kg)	Thread Size A	B	C	D	E	F	G	H	I	J	K	L	Hex Size M	Torque (N•m)	Weight (kg)
23956	400	M8 X 1.25	1.2	12	12.7	25.4	25.4	8.7	6.3	38.1	57.2	62.7	91.3	19	10	0.27
23958	450	M10 X 1.5	1.2	15	12.7	25.4	25.4	8.7	6.3	38.1	57.2	62.7	91.3	19	17	0.27
23962	1050	M12 X 1.75	1.6	18	25.4	50.8	38.1	14.3	19	76.2	112.7	101.6	161.9	32	37	1.64
23965	1900	M16 X 2.0	1.6	24	25.4	50.8	38.1	14.3	19	76.2	112.7	101.6	161.9	32	80	1.64
23968	2150	M20 X 2.5	1.6	30	25.4	50.8	38.1	14.3	19	76.2	112.7	101.6	161.9	32	134	1.7
23974	4200	M24 X 3.0	1.6	35.7	47.6	96.0	76.2	27.0	31.7	91.3	147.6	207.2	245.3	63.5	305	7.1
23975	4200	M24 X 3.0	1.6	47.6	47.6	96.0	76.2	27.0	31.7	91.3	147.6	207.2	245.3	63.5	305	7.2
23978	7000	M30 X 3.5	1.6	44.8	47.6	96.0	76.2	27.0	31.7	91.3	147.6	207.2	245.3	63.5	590	7.3
23979	7000	M30 X 3.5	1.6	60.0	47.6	96.0	76.2	27.0	31.7	91.3	147.6	207.2	245.3	63.5	590	7.4
23982	11000	M36 X 4.0	2.8	53.6	63.5	123.8	114.3	36.5	44.5	114.3	196.1	290.5	351.6	82.55	960	19.1
23983	11000	M36 X 4.0	2.8	71.4	63.5	123.8	114.3	36.5	44.5	114.3	196.1	290.5	351.6	82.55	960	19.3
23984	12500	M42 X 4.5	2.8	62.7	63.5	123.8	114.3	36.5	44.5	114.3	196.1	290.5	351.6	82.55	980	19.4
23985	12500	M42 X 4.5	2.8	83.3	63.5	123.8	114.3	36.5	44.5	114.3	196.1	290.5	351.6	82.55	980	19.6
23986	13500	M48 X 5.0	2.8	71.4	63.5	123.8	114.3	36.5	44.5	114.3	196.1	290.5	351.6	82.55	980	19.7
23987	13500	M48 X 5.0	2.8	95.3	63.5	123.8	114.3	36.5	44.5	114.3	196.1	290.5	351.6	82.55	980	20.0



Center-Pull Traditional Style



- Full 360° Swivel and 180° Pivot Action
- Rated at 5:1 Strength Factor
- Material: Alloy Steel
- Finish: Black Oxide (Except Washer)
- U-Bar, Bolt, Pins, Base, Washer and Bushing are Magnetic Particle Inspected
- Washer: Zinc Plated with Gold Colored (Inch), Clear/Blue (Metric) Conversion Coating
- Proof Tested to 200% of Rated Load Capacity
- Certificate of Proof Test provided (See sample on page 22)
- 3D Solid Models available in multiple formats from www.jergensinc.com
- Available with Envirolox™ protective finish. See page 15 for more information.

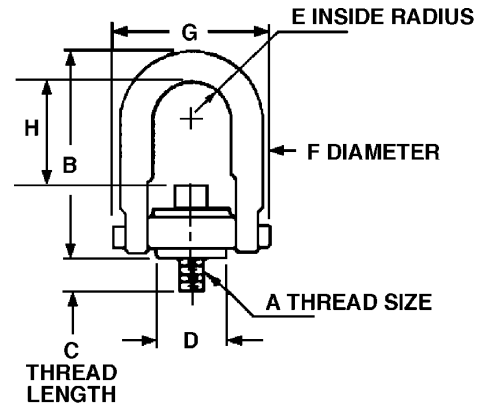

To add Lift ID™ to Hoist Ring
Add "F" to the end of the part
number Example: 23414F



Thread Size A	Load ¹ Capacity (lbs)	Black Oxide				Envirolox™ Protected Coating				Thread length C	D	E	F	G	Std U-Bar H	Long U-Bar H	Torque ²	Wt
		Standard U-Bar		Long U-Bar		Standard U-Bar		Long U-Bar										
		Part Number	B	Part Number	B	Part Number ³	B	Part Number	B									
1/4-20	550	23404	2.67	—	—	23304	2.67	—	—	1/2	.75	.43	.38	1.84	1 5/16	—	5	.3
5/16-18	800	23405	2.67	—	—	23305	2.67	—	—	1/4	.75	.43	.38	1.84	1 1/4	—	7	.3
5/16-18	800	23406	2.67	—	—	23306	2.67	—	—	9/16	.75	.43	.38	1.84	1 1/4	—	7	.3
3/8-16	1000	23408	2.67	—	—	23308	2.67	—	—	9/16	.75	.43	.38	1.84	1 1/4	—	12	.3
1/2-13	2500	23410	3.75	—	—	23310	3.75	—	—	1 1/16	1.20	.69	.50	2.56	1 25/32	—	28	1.0
1/2-13	2500	23411	4.78	23511	6.72	23311	4.78	23511-E	6.72	3/4	1.50	.88	.75	3.52	2 3/8	4 1/4	28	2.5
1/2-13	2500	23412	4.78	23512	6.72	23312	4.78	23512-E	6.72	1	1.50	.88	.75	3.52	2 3/8	4 1/4	28	2.5
1/2-13	2500	23413	4.78	23513	6.72	23313	4.78	23513-E	6.72	1 1/4	1.50	.88	.75	3.52	2 3/8	4 1/4	28	2.5
5/8-11	4000	23414	4.78	23514	6.72	23314	4.78	23514-E	6.72	1	1.50	.88	.75	3.52	2 1/4	4 3/16	60	2.7
5/8-11	4000	23415	4.78	23515	6.72	23315	4.78	23515-E	6.72	1 1/4	1.50	.88	.75	3.52	2 1/4	4 3/16	60	2.7
5/8-11	4000	23416	4.78	23516	6.72	23316	4.78	23516-E	6.72	3/4	1.50	.88	.75	3.52	2 1/4	4 3/16	60	2.7
3/4-10	5000	23417	4.78	23517	6.72	23317	4.78	23517-E	6.72	1	1.50	.88	.75	3.52	2 1/8	4	100	3.0
3/4-10	5000	23418	4.78	23518	6.72	23318	4.78	23518-E	6.72	1 1/2	1.50	.88	.75	3.52	2 1/8	4	100	3.0
3/4-10	7000	23420	6.52	23520	8.11	23320	6.52	23520-E	8.11	1	2.31	1.40	1.00	5.14	2 15/16	4	100	7.0
3/4-10	7000	23421	6.52	23521	8.11	23321	6.52	23521-E	8.11	1 1/2	2.31	1.40	1.00	5.14	2 15/16	4	100	7.0
7/8-9	8000	23423	6.52	23523	8.11	23323	6.52	23523-E	8.11	1	2.31	1.40	1.00	5.14	2 13/16	4 3/8	160	7.0
7/8-9	8000	23424	6.52	23524	8.11	23324	6.52	23524-E	8.11	1 1/4	2.31	1.40	1.00	5.14	2 13/16	4 3/8	160	7.0
1-8	10000	23425	6.52	23525	8.11	23325	6.52	23525-E	8.11	1 1/4	2.31	1.40	1.00	5.14	2 11/16	4 3/8	230	7.5
1-8	10000	23426	6.52	23526	8.11	23326	6.52	23526-E	8.11	1 1/2	2.31	1.40	1.00	5.14	2 11/16	4 3/8	230	7.5
1-8	10000	23427	6.52	23527	8.11	23327	6.52	23527-E	8.11	2 1/4	2.31	1.40	1.00	5.14	2 11/16	4 3/8	230	7.5
1 1/4-7	15000	23429	8.73	—	—	23329	8.73	—	—	1 7/8	3.19	1.75	1.25	6.50	4 1/4	—	470	14
1 1/4-8	15000	23429-08	8.73	—	—	—	8.73	—	—	1 7/8	3.19	1.75	1.25	6.50	4 1/4	—	470	14
1 1/2-6	24000	23433	12.47	—	—	23333	12.47	—	—	2 3/4	4.19	2.25	1.75	8.55	6 1/2	—	800	33
1 1/2-8	24000	23433-08	12.47	—	—	—	12.47	—	—	2 3/4	4.19	2.25	1.75	8.55	6 1/2	—	800	33
2-4 1/2	30000	23435	12.47	—	—	23335	12.47	—	—	3 1/8	4.19	2.25	1.75	8.55	6	—	1100	36
2-8	30000	23435-08	12.47	—	—	—	12.47	—	—	3 1/8	4.19	2.25	1.75	8.55	6	—	1100	36
2 1/2-4	50000	23438	16.50	—	—	23338	16.50	—	—	4	5.75	3	2.25	11.72	8 1/4	—	2100	89
2 1/2-8	50000	23438-08	16.50	—	—	—	16.50	—	—	4	5.75	3	2.25	11.72	8 1/4	—	2100	89

¹ Stated load capacity based on recommended thread torques as shown in chart.

² It is recommended that these torques be used when installing hoist rings.

³ Available from stock as Standard Clevis.

Center-Pull Traditional Style Metric

Thread Size A	Load ¹ Capacity (kg)	Black Oxide				Envirolox™ Protected Coating				Thread length C	D	E	F	G	Std U-Bar H	Long U-Bar H	Torque ² (kg•m)	Wt. (kg)
		Standard U-Bar		Long U-Bar		Standard U-Bar		Long U-Bar										
		Part Number	B	Part Number	B	Part Number	B	Part Number ³	B									
M6 x 1.0	200	23455	67.8	-	-	23355	67.8	-	-	12.0	19.0	10.9	9.7	46.7	34.0	-	0.6	0.17
M8 x 1.25	400	23456	67.8	-	-	23356	67.8	-	-	12.5	19.0	10.9	9.7	46.7	32.0	-	1.0	0.17
M10 x 1.50	450	23458	67.8	-	-	23358	67.8	-	-	17.5	19.0	10.9	9.7	46.7	30.0	-	1.7	0.17
M12 x 1.75	1050	23462	123.0	23562	170.7	23362	123.0	23562-E	170.7	19.0	38.1	22.4	19.0	89.4	60.5	108	3.8	1.1
M16 x 2.0	1900	23465	123.0	23565	170.7	23365	123.0	23565-E	170.7	29.0	38.1	22.4	19.0	89.4	56.5	106	8.2	1.1
M20 x 2.5	2150	23468	123.0	23568	170.7	23368	123.0	23568-E	170.7	34.0	38.1	22.4	19.0	89.4	52.5	101	13.6	1.2
M20 x 2.5	3000	23471	163.0	23571	206.0	23371	163.0	23571-E	206.0	32.0	58.7	35.6	25.4	130.6	73.0	101	13.6	3.0
M24 x 3.0	4200	23474	163.0	23574	206.0	23374	163.0	23574-E	206.0	37.0	58.7	35.6	25.4	130.6	69.0	111	31.0	3.1
M30 x 3.5	7000	23478	221.7	-	-	23378	221.7	-	-	46.0	81.0	44.5	31.7	165.1	107.4	-	60.0	6.3
M30 x 3.5	7000	23479	221.7	-	-	23379	221.7	-	-	66.0	81.0	44.5	31.7	165.1	107.4	-	60.0	6.4
M36 x 4.0	11000	23483	316.7	-	-	23383	316.7	-	-	68.0	106.4	57.2	44.4	217.2	166.5	-	100.0	15.5
M42 x 4.5	12500	23484	316.7	-	-	23384	316.7	-	-	68.0	106.4	57.2	44.4	217.2	160.5	-	100.0	16.0
M48 x 5.0	13500	23485	316.7	-	-	23385	316.7	-	-	88.0	106.4	57.2	44.4	217.2	154.5	-	100.0	16.8
M64 x 6.0	22500	23488	419.1	-	-	23388	419.1	-	-	96.0	146.0	76.2	57.1	297.6	210.0	-	290.0	40.0

All dimensions are in millimeters. ¹Stated load capacity is based upon specific thread torques shown in chart. ²It is recommended that these torques be used when installing hoist rings. ³Available from stock as Standard Clevis.

Bolt Replacement Kits - Inch threads

Black Oxide Hoist Rings			Envirolox™ Coated			Kit Wt. (lbs)
Std. U-Bar Part No.	Long U-Bar Part No.	Bolt Kit Part No.	Std. U-Bar Part No.	Long U-Bar Part No.	Bolt Kit Part No.	
23404		23604	23304		23604-E	
23405		23605	23305		23605-E	
23406		23606	23306		23606-E	.03
23408		23608	23308		23608-E	.05
23410		23610	23310		23610-E	.16
23411	23511	23611	23311	23511-E	23611-E	.14
23412	23512	23612	23312	23512-E	23612-E	.16
23413	23513	23613	23313	23513-E	23613-E	.17
23414	23514	23614	23314	23514-E	23614-E	.27
23415	23515	23615	23315	23515-E	23615-E	.29
23416	23516	23616	23316	23516-E	23616-E	
23417	23517	23617	23317	23517-E	23617-E	.40
23418	23518	23618	23318	23518-E	23618-E	.46
23420	23520	23620	23320	23520-E	23620-E	.46
23421	23521	23621	23321	23521-E	23621-E	.52
23423	23523	23623	23323	23523-E	23623-E	.62
23424	23524	23624	23324	23524-E	23624-E	.66
23425	23525	23625	23325	23525-E	23625-E	.92
23426	23526	23626	23326	23526-E	23626-E	.97
23427	23527	23627	23327	23527-E	23627-E	1.13
23429		23629	23329		23629-E	2.90
23429-08		23629-08				2.90
23433		23633	23333		23633-E	3.50
23433-08		23633-08				3.50
23435		23635	23335		23635-E	7.30
23435-08		23635-08				7.30
23438		23638	23338		23638-E	15.66
23438-08		23638-08				15.96

Bolt Replacement Kits - Metric threads

Black Oxide Hoist Rings			Envirolox™ Coated			Kit Wt. (kg)
Std. U-Bar Part No.	Long U-Bar Part No.	Bolt Kit Part No.	Std. U-Bar Part No.	Long U-Bar Part No.	Bolt Kit Part No.	
		23655			23655-E	.02
23456		23656	23356		23656-E	.02
23458		23658	23358		23658-E	.03
23462	23562	23662	23362	23562-E	23662-E	.06
23465	23565	23665	23365	23565-E	23665-E	.12
23468	23568	23668	23368	23568-E	23668-E	.21
23471	23571	23671	23371	23571-E	23671-E	.23
23474	23574	23674	23374	23574-E	23674-E	.40
23478		23678	23378		23678-E	.79
23479		23679	23379		23679-E	.91
23483		23683	23383		23683-E	1.52
23484		23684	23384		23684-E	2.75
23485		23685	23385		23685-E	3.27
23488		23688	23388		23688-E	7.12

Bolt Kits contain bolt and retaining ring.
• See page 15 for Hoist Ring hold down clips.



To add Lift ID™ to Hoist Ring
Add "F" to the end of the part number
Example: 23414F





Side-Pull Traditional Style Precision Cast Body



- Rated at 5:1 Strength Factor
- Material: Alloy Steel
- Clevis, Ring, Bushing and Cap Screw are magnetic particle inspected
- Clevis is x-rayed
- Finish: Black Oxide
- Bushing: Zinc Plated with conversion coating, yellow (inch), clear blue (metric)
- Proof Tested to 200% of Rated Load Capacity
- 3D Solid Models available in multiple formats from www.jergensinc.com
- Available with Envirolox™ protective finish. See page 15 for more information.

360° swivel plus pivot point moves around bolt to provide greater clearances in side lifting and when lifting rotating objects.



To add Lift ID™ to Hoist Ring
Add "F" to the end of the part number
Example: 23414F

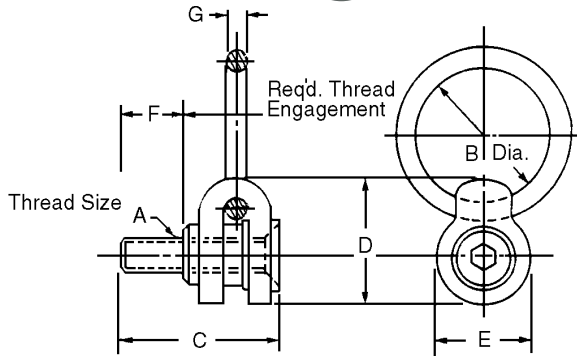

Inch

Part Number	Envirolox™ Part Number	Load ¹ Capacity (lbs)	A	B	C	D	E	F	G	Torque ² (ft. lbs)	Wt. (lbs)
47311	47311-E	650	5/16-18	2	2 1/8	2	1 1/2	5/8	3/8	3.5	.25
47312	47312-E	800	3/8-16	2	2 3/8	2	1 1/2	3/4	3/8	4.5	.25
47313	47313-E	1800	1/2-13	3	3 3/8	3 3/16	2 3/8	1	5/8	15.0	3.25
47314	47314-E	2500	5/8-11	3	3 5/8	3 3/16	2 3/8	1 1/4	5/8	25.0	3.25
47315	47315-E	4100	3/4-10	4	5	5	3 3/4	1 1/2	1	50.0	11.25
47316	47316-E	7100	1-8	4	5 3/8	5	3 3/4	2	1	90.0	11.50
47317	47317-E	14000	1 1/4-7	6	6 7/8	6 13/16	4 5/8	2	1 3/8	150.0	27.75
47317-08		14000	1 1/4-8	6	6 7/8	6 13/16	4 5/8	2	1 3/8	150.0	27.75
47318	47318-E	17200	1 1/2-6	6	7 7/8	6 13/16	4 5/8	2 1/2	1 3/8	250.0	31.50
47318-08		17200	1 1/2-8	6	7 7/8	6 13/16	4 5/8	2 1/2	1 3/8	250.0	31.50
47319	47319-E	29000	2-4 1/2	5 1/4 x 10 1/2	10	6 13/16	4 5/8	3 1/8	1 1/2	300.0	42.00
47319-08		29000	2-8	5 1/4 x 10 1/2	10	6 13/16	4 5/8	3 1/8	1 1/2	300.0	42.00

¹ Stated load capacity based on specific thread torques as shown in chart.

² It is recommended that these torques be used when installing hoist rings.



Side-Pull Traditional Style Precision Cast Body

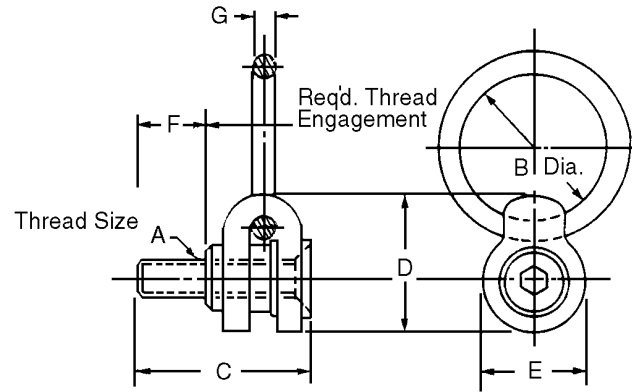

Metric

Part Number	Envirolox™ Part Number	Load ¹ Capacity (kg)	A	B	C	D	E	F	G	Torque ² (kg·M)	Wt. (kg)
47351	47351-E	325	M 8 x 1.25	50.8	61.0	50.8	38.1	16.0	9.5	.43	.12
47352	47352-E	500	M 10 x 1.50	50.8	63.0	50.8	38.1	20.0	9.5	.60	.12
47353	47353-E	725	M 12 x 1.75	76.2	85.0	81	60.3	24.0	15.9	2.00	1.5
47354	47354-E	1400	M 16 x 2.0	76.2	94.0	81	60.3	31.0	15.9	3.50	1.5
47355	47355-E	2290	M 20 x 2.5	101.6	133.0	125.4	95.3	40.0	25.4	7.00	5.1
47356	47356-E	3050	M 24 x 3.0	101.6	147.0	125.4	95.3	47.0	25.4	12.50	5.2
47357	47357-E	4850	M 30 x 3.5	152.0	173.8	173.0	117.5	49.0	31.7	34.6	12.6
47358	47358-E	7500	M 36 x 4.0	152.0	191.0	173.0	117.5	67.5	35.0	55.0	14

All dimensions are in millimeters.

¹Stated load capacity based on specific thread torques as shown in charts.

²It is recommended that these torques be used when installing hoist rings.

Bolt Replacement Kits

Inch Thread

Hoist Ring Part No.	Bolt Kit Part No.	Envirolox™ Bolt Kit Part No.	Thread Size	Wt. (lbs)
47311	47341	47341-E	5/16-18	.05
47312	47342	47342-E	3/8-16	.06
47313	47343	47343-E	1/2-13	.17
47314	47344	47344-E	5/8-11	.28
47315	47345	47345-E	3/4-10	.59
47316	47346	47346-E	1-8	1.27
47317	47347	47347-E	1 1/4-7	2.50
47317-08	47347-08		1 1/4-8	2.50
47318	47348	47348-E	1 1/2-6	4.70
47318-08	47348-08		1 1/2-8	4.70
47319	47349	47349-E	2-4 1/2	9.50
47319-08	47349-08		2-8	9.50

Metric Thread

Hoist Ring Part No.	Bolt Kit Part No.	Envirolox™ Bolt Kit Part No.	Thread Size	Wt. (kg)
47351	47391	47391-E	M 8	.02
47352	47392	47392-E	M 10	.03
47353	47393	47393-E	M 12	.07
47354	47394	47394-E	M 16	.14
47355	47395	47395-E	M 20	.32
47356	47396	47396-E	M 24	.53
47357	47397	47397-E	M 30	1.03
47358	47398	47398-E	M 36	2.0

Bolt Kits contain bolt and retaining ring.

Bolt Kits with -E are for use with Envirolox™ Hoist Rings.

- See page 15 for Hoist Ring hold down clips.



LIFT ID
AUTOMATED INSPECTION AND COMPLIANCE SYSTEM

To add Lift ID™ to Hoist Ring
Add "F" to the end of the part
number Example: 23414F





SP 2000™ Side-Pull Style Extended D Ring



The Jergens SP2000 Side-Pull Style Hoist Ring is ideal for flipping fixtures, dies and molds. It swivels 360° and pivots around the center bolt providing the ring with greater clearances in side lifting applications and when lifting rotating objects. The hoist ring is low profile and has a unique bolt retention design. The oversized forged ring, and single piece forging, easily adapts to larger hoist hooks. Its relatively light weight makes it easier to handle than similar hoist rings and the installation is conveniently done with external wrenching (47531, 47532) or internal/external wrenching (all other sizes). All parts are made in the U.S.A.

- Can Be Used for Top Lifting as well as side lifting applications
- Full Swivel & Pivot Action
- Rated at 5:1 strength factor at any angle
- Material: Heat Treated Alloy Steel
- Finish: Black Oxide
- Proof Tested to 200% of Rated Load Capacity
- Available in Metric sizes. See page 13.
- 3D Solid Models available in multiple formats from www.jergensinc.com



LIFT ID™ To add Lift ID™ to Hoist Ring
Add "F" to the end of the part number Example: 23414F



Patent Nos. 6,068,310
and 409,895

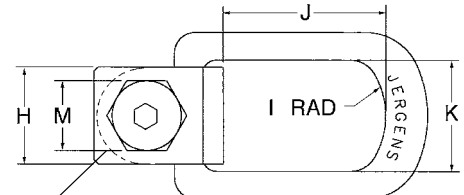
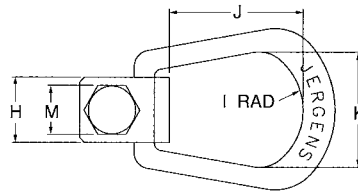

*For Part Numbers: 47537, 47538, 47539

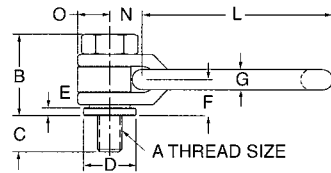

External Wrench Mounting
Part Numbers: 47531 & 47532

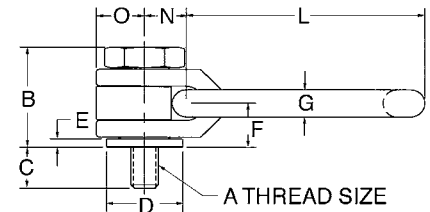

Internal/External Wrench Mounting
Part Numbers: 47533 thru 47539

Inch Threads (Includes Gold Spacer)

Part Number	Load Capacity (lbs)	Thread Size A	B	C	D	E	F	G	H	I	J	K	L	M	N	O	Torque (ft. lbs)	Hex Size	Wt. (lbs)
47531	650	5/16-18	1 9/32	15/32	13/16	1/8	9/16	5/16	1	1	2 1/16	1 3/4	3	3/4	1/2	1/2	4	—	.5
47532	800	3/8-16	1 9/32	5/8	13/16	1/8	9/16	5/16	1	1	2 1/16	1 3/4	3	3/4	1/2	1/2	5	—	.5
47533	1800	1/2-13	1 7/8	3/4	1 3/8	5/32	13/16	1/2	1 3/4	1 1/2	3 3/8	2	4 3/4	1 1/4	3/4	7/8	15	1/4	2
47534	2500	5/8-11	1 7/8	15/16	1 3/8	5/32	13/16	1/2	1 3/4	1 1/2	3 3/8	2	4 3/4	1 1/4	3/4	7/8	25	5/16	2
47535	4100	3/4-10	2 5/16	1 1/8	1 7/8	1/4	1 1/32	5/8	2 1/4	2	4	2 5/8	5 11/16	1 3/4	1	1 1/8	50	3/8	4
47536	7100	1-8	2 5/16	1 1/2	1 7/8	1/4	1 1/32	5/8	2 1/4	2	4	2 5/8	5 11/16	1 3/4	1	1 1/8	130	1/2	4.5
*47537	14000	1 1/4-7	4 9/16	1 7/8	3 1/4	23/64	1 21/32	1 1/16	3 3/4	3	7 11/16	4 3/8	10 7/16	3	1 5/16	1 7/8	150	3/4	24.50
*47538	17200	1 1/2-6	4 9/16	2 1/4	3 1/4	23/64	1 21/32	1 1/16	3 3/4	3	7 11/16	4 3/8	10 7/16	3	1 5/16	1 7/8	250	3/4	30
*47539	29000	2-4 1/2	4 9/16	3	3 1/4	23/64	1 21/32	1 1/16	3 3/4	3	7 11/16	4 3/8	10 7/16	3	1 5/16	1 7/8	300	3/4	26.50

SP 2000™ Side-Pull Metric - Extended D Ring



SIDE PULL APPLICATION



TOP PULL APPLICATION

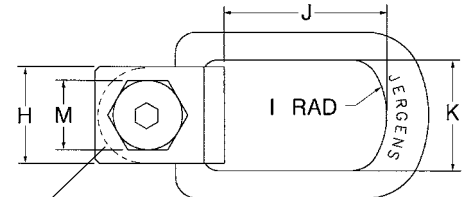
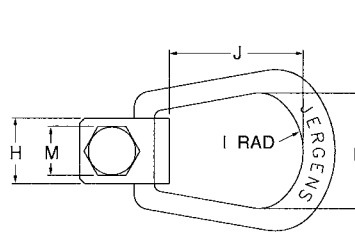

*For Part Numbers: 47587, 47588, 47591, 47589

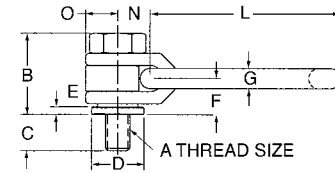

External Wrench Mounting
Part Numbers: 47581 & 47582

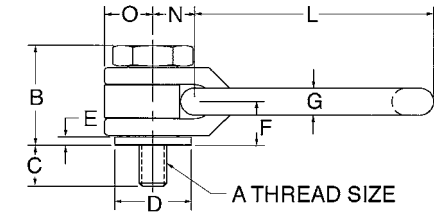

Internal/External Wrench Mounting
Part Numbers: 47583 thru 47589, 47591

Patent Nos. 6,068,310
and 409,895

Metric Threads (Includes Blue Spacer)

Part Number	Load Capacity (kg)	Thread Size A	B	C	D	E	F	G	H	I	J	K	L	M	N	O	Torque (N•m)	Hex Size	Wt. (kg)
47581	325	M8 x 1.25	33	16	21	3	14	8	25	25	52	44	76	19	13	13	5	—	.25
47582	500	M10 x 1.5	33	20	21	3	14	8	25	25	52	44	76	19	13	13	10	—	.25
47583	725	M12 x 1.75	48	24	35	4	21	13	44	38	86	51	120	32	19	22	20	6	1
47584	1400	M16 x 2	48	32	35	4	21	13	44	38	86	51	120	32	19	22	40	8	1
47585	2290	M20 x 2.5	59	40	48	6	26	16	57	51	102	67	145	44	25	29	70	10	2
47586	3050	M24 x 3	59	48	48	6	26	16	57	51	102	67	145	44	25	29	140	12	2
*47587	4850	M30 x 3.5	117	60	83	9	52	27	95	76	196	111	265	76	49	48	350	19	11.1
*47588	7500	M36 x 4	117	72	83	9	52	27	95	76	196	111	265	76	49	48	550	19	11.3
*47591	8700	M42 x 4.5	117	84	83	9	52	27	95	76	196	111	265	76	49	48	800	19	11.8
*47589	10000	M48 x 5	122	96	83	9	52	27	95	76	196	111	265	80	49	48	1200	27	12.5

All dimensions are in millimeters.



To add Lift ID™ to Hoist Ring
Add "F" to the end of the part
number Example: 23414F





Side Swivel



U.S. Patent No. 6,443,514

Jergens new Side Swivel™ Lifting Ring is designed specifically for OEM type applications. It replaces potentially dangerous eyebolts on commercial, military, and industrial lifts requiring full swivel and pivoting action.

- 5:1 strength factor-forged ring
- Unique 3 piece design
- Made in U.S.A.
- Capacities up to 4100 lbs.
- Inch and metric
- OEM Pricing
- 3D Solid Models available in multiple formats from www.jergensinc.com

Ideally suited for OEM applications



Small Side Swivel*

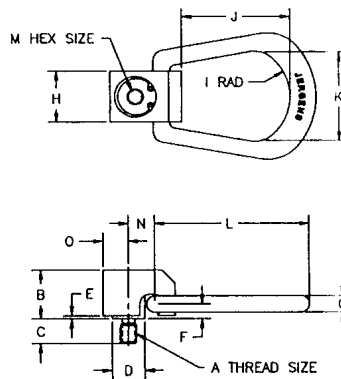

Large Side Swivel

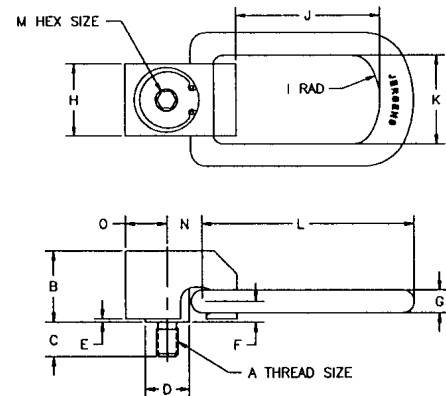

To add Lift ID™ to Hoist Ring
Add "F" to the end of the part
number Example: 23414F



Part Number	Load Capacity (lbs)	Thread Size A	B	C	D	E	F	G	H	I	J	K	L	Hex Size M	N	O	Torque (ft.lbs)	Weight (lbs)
47800*	650	5/16-18	15/16	15/32	5/8	1/16	9/32	5/16	1	1	2 1/16	1 3/4	2 31/32	1/4	1/2	1/2	3.5	0.6
47801*	800	3/8-16	15/16	9/16	5/8	1/16	9/32	5/16	1	1	2 1/16	1 3/4	2 31/32	1/4	1/2	1/2	4.5	0.6
47802	1800	1/2-13	1 37/64	3/4	1	5/64	7/16	1/2	1 5/8	1 1/2	3 1/4	2	4 3/4	3/8	25/32	15/16	15	2.5
47803	2500	5/8-11	1 37/64	15/16	1	5/64	7/16	1/2	1 5/8	1 1/2	3 1/4	2	4 3/4	3/8	25/32	15/16	25	2.5
47804	4100	3/4-10	1 37/64	1 1/8	1	5/64	7/16	1/2	1 5/8	1 1/2	3 1/4	2	4 3/4	3/8	25/32	15/16	50	2.5

* Small Side Swivel

Metric

Part Number	Load Capacity (kg)	Thread Size A	B	C	D	E	F	G	H	I	J	K	L	Hex Size M	N	O	Torque (N•m)	Weight (kg)
47850*	325	M8 x 1.25	23.8	15.8	15.8	1.6	7.2	7.9	25.4	25.4	52.4	44.5	75.4	6	12.7	12.7	4.2	.27
47851*	500	M10 x 1.5	23.8	19.8	15.8	1.6	7.2	7.9	25.4	25.4	52.4	44.5	75.4	6	12.7	12.7	6	.27
47852	725	M12 x 1.75	40.1	23.8	25.4	2.0	11.1	12.7	41.3	38.1	82.6	50.8	120.7	10	20	24	20	1.14
47853	1400	M16 x 2.0	40.1	31.8	25.4	2.0	11.1	12.7	41.3	38.1	82.6	50.8	120.7	10	20	24	40	1.14
47854	2290	M20 x 2.5	40.1	39.7	25.4	2.0	11.1	12.7	41.3	38.1	82.6	50.8	120.7	10	20	24	70	1.18

* Small Side Swivel

Envirolox™ Protective Finish



The Envirolox™ Protective Finish is a *proprietary nickel based coating that helps to prevent rusting and other environmental hazards from affecting Jergens Hoist Rings.* This coating does not contain cadmium or chromium, is *environmentally friendly*, and is proven to be *effective in extreme conditions.* It provides surface hardness, lubricity and more effective corrosion protection than paints. Envirolox™ Protective Finish is available on Jergens Center-Pull and Side-Pull Style Hoist Rings. It is not recommended for the Swivel Eyebolt or the SP 2000 products.

- Available on Center-Pull and Side-Pull Traditional Style Hoist Rings (See pages 8-9 and 10-11 for part numbers.)
- Available upon request for other selected Jergens lifting products.
- Protects against rusting
- Environmentally safe

Hoist Ring Hold Down Clips

Two or more Hoist Ring Hold Down Clips should be used to prevent ring movement when the hoist ring is not in use. These simple spring steel clips prevent ring movement, provide an additional safety feature when used around machine tools and give a neat finished appearance.

- Material: Spring, Steel
- Finish: Cadmium or Zinc



To add Lift ID™ to Hoist Ring
Add "F" to the end of the part
number **Example: 23414F**

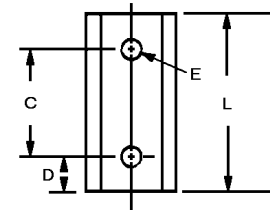
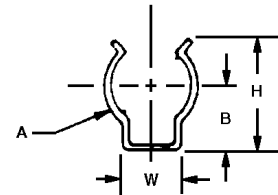

Clip Part Number	Diameter		C	D	E	H	W	L
	A	B						
47331	3/8	.330	—	.250	.125	.575	.320	.500
47332	1/2	.388	.250	.125	.151	.712	.385	.500
47333	5/8	.450	.250	.125	.151	.832	.385	.500
47334	3/4	.513	.312	.156	.151	1.000	.385	.625
47335	1	.683	.312	.188	.188	1.133	.510	.687
47336	1 1/4	.750	.625	.187	.162	1.370	1.330	1.000
47337	1 3/8	.880	.312	.188	.188	1.439	.510	.688
47338	1 7/16	.850	.937	.312	.103	1.560	1.560	1.500
47339	1 3/4	1.070	.312	.188	.130	1.830	.780	.688



Kwik-Lok® Lifting Pins

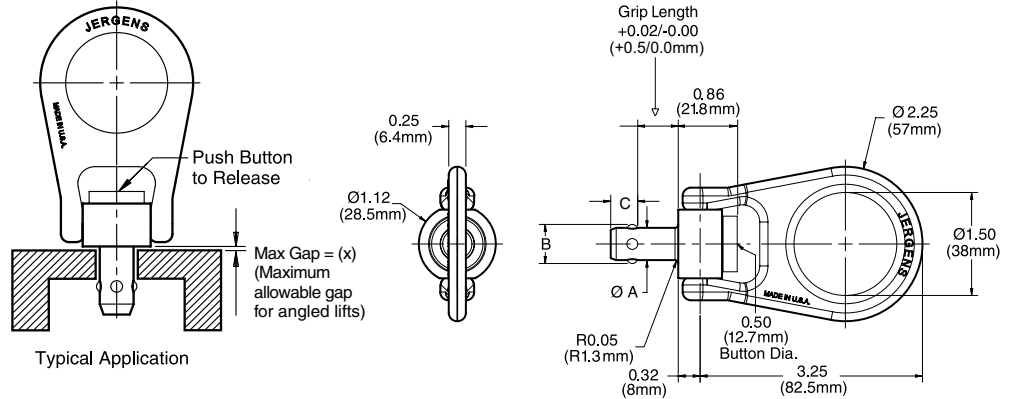

Lifting Pin Specifications - Inches

Nom Pin Dia	Max. Load Rating (lbs)*	ØA		+/-0.005 B	+0.00/-0.04 C	Max. Gap (X) (in)	Required Hole Diameter (in)	
		Min	Max				Max	Min
1/4	400	.2470	.2485	.286	.290	0.06	0.2540	0.2500
5/16	700	.3095	.3110	.375	.330	0.06	0.3165	0.3125
3/8	1,000	.3720	.3735	.440	.365	0.06	0.3790	0.3750
1/2	1,250	.4970	.4985	.594	.460	0.06	0.5050	0.5000
5/8	1,400	.6220	.6235	.750	.580	0.06	0.6300	0.6250

Lifting Pin Specifications - Metric

Nom Pin Dia	Max. Load Rating (kN)*	ØA		+/-0.25 B	+0.0/-1.0 C	Max. Gap (X) (mm)	Required Hole Diameter (mm)	
		Min	Max				Max	Min
10	4.4	9.92	9.96	12.00	9	1.5	10.1	10.0
12	5.5	11.92	11.96	14.27	10	1.5	12.1	12.0
16	6.2	15.92	15.96	19.00	14	1.5	16.1	16.0

*Dimensions in millimeters



To add Lift ID™ to Hoist Ring
Add "F" to the end of the part number
Example: 23414F



Kwik-Lok® Lifting Pin - Inches

Dia.	Grip Length							
	0.50	0.75	1.00	1.25	1.50	2.00	2.50	3.00
1/4	807216	807217	807218	807219	807220	807222	807224	807225
5/16	807232	807233	807234	807235	807236	807238	807240	807241
3/8	807248	807249	807250	807251	807252	807254	807256	807257
1/2	807280	807281	807282	807283	807284	807286	807288	807289
5/8	807312	807313	807314	807315	807316	807318	807320	807321

Kwik-Lok® Lifting Pin - Metric

Dia.	Grip Length							
	15	20	25	30	35	40	50	75
10	857237	857238	857239	857240	857299	857241	857242	857307
12	857249	857250	857251	857252	857300	857253	857254	857308
16	857261	857262	857263	857264	857301	857265	857266	857309

Important: Please review all operating instructions that are included in the packaging or online before use.

Note: If the required hole size cannot be achieved; Jergens recommends the use of our threaded receptacle (see page 17); Please Contact Customer Service with any questions.

*Lifting load ratings are based on tests with hardened tool steel plates or shoulder bushings. Load ratings may be reduced if oversized holes or parent material under 80,000 psi tensile are used.

*Kwik-Lok® Lifting Pins are not suited for continuous rotation under load.



Threaded Receptacles

High Strength Stainless Steel, 17-4 PH heat treated



KLP Threaded Receptacles - Inch

For Kwik-Lok® Lifting Pin Size	For Kwik-Lok® Lifting Pin Part Number	Use Receptacle Part Number	Thread Size A	Overall Length B	Head Height C	Head Flats D	Diameter E	Install Torque (ft-lbs)
5/16x0.5	807232	845101	3/4-10	1.100	0.28	.87	1.12	18
3/8x0.5	807248	845102	3/4-10	1.100	0.28	.87	1.12	25
1/2x0.5	807280	845103	1 1/8-7	1.625	0.37	1.25	1.62	47
5/8x0.5	807312	845104	1 1/8-7	1.625	0.37	1.25	1.62	53

KLP Threaded Receptacles - Metric

For Kwik-Lok® Lifting Pin Size	For Kwik-Lok® Lifting Pin Part Number	Use Receptacle Part Number	Thread Size A	Overall Length B	Head Height C	Head Flats D	Diameter E	Install Torque (kg-m)
12x15	857249	855101	M22x2.5	37	9	30	34.8	5.0
16x15	857261	855102	M27x3	41	10	32	41.2	6.9

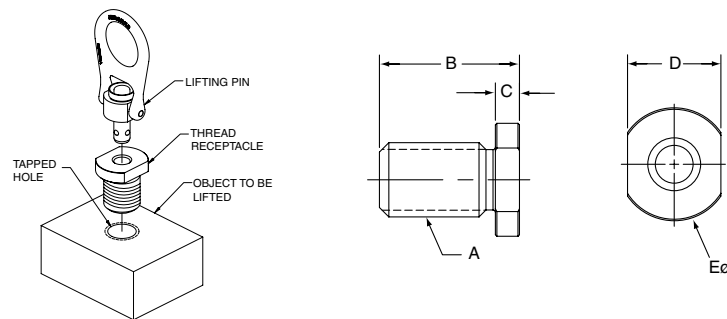

Kwik-Lok® Lifting Pin Kits - Inch



Kit Part Number	Kwik-Lok® Lifting Pin Size	Receptacle Thread Size	Kwik-Lok® Lifting Pin Part Number	Threaded Receptacle Part Number
847216	1/4 x 0.5	1/2-13	807216	845100
847232	5/16 x 0.5	3/4-10	807232	845101
847248	3/8 x 0.5	3/4-10	807248	845102
847280	1/2 x 0.5	1 1/8-7	807280	845103
847312	5/8 x 0.5	1 1/8-7	807312	845104

*Each kit contains one Kwik-Lok® lifting pin and one corresponding Threaded Receptacle.

Kwik-Lok® Lifting Pin Kits - Metric

Kit Part Number	Kwik-Lok® Lifting Pin Size	Receptacle Thread Size	Kwik-Lok® Lifting Pin Part Number	Threaded Receptacle Part Number
877237	M10 x 15	M20 x 2.5	857237	855100
877249	M12 x 15	M22 x 2.5	857249	855101
877261	M16 x 15	M27 x 3	857261	855102

*Each kit contains one Kwik-Lok® lifting pin and one corresponding Threaded Receptacle.



Swivel Eyebolt



The Jergens Swivel Eyebolt™ lifting product has a full swivel and pivoting action that allows for the flipping and turning of the part without unhooking. The patented tamper resistant design is ideal for permanent mounting on OEM applications or on molds, dies and fixtures.



- Tamper Resistant Design
- Swivels 360°, Pivots 180°
- Eliminates Bending (of Eyebolt) Problem
- Forged, Oversized, One-Piece Lift Ring
- Rated at 5:1 Strength Factor
- Load Capacities to 4000 Lbs/2000 Kg
- Economically Priced
- Material: Alloy Steel, or 316 Stainless Steel
- Finish: Black Oxide, or Passivated (SS)
- 3D Solid Models available in multiple formats from www.jergensinc.com

U.S. Patent Nos. 5,634,734 and 5,743,576
Foreign Patent Pending



LIFT ID
AUTOMATED INSPECTION AND COMPLIANCE SYSTEM

To add Lift ID™ to Hoist Ring
Add "F" to the end of the part number
Example: 23414F

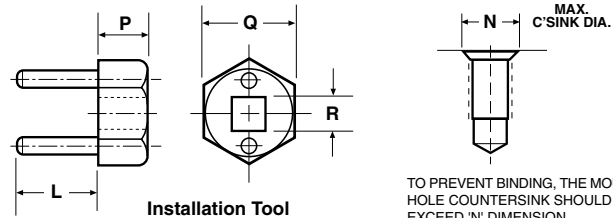

Installation Tool Information

Installation Tool Part Number	Pin Length L	Head Thickness P	Hex Size Q	Square Drive R
47641	11/16	.55	15/16	1/4
47643	1 1/8	.65	1 1/4	3/8

Swivel Eyebolt Part Number	Installation Tool Part Number	Recommended Torque	Maximum Countersink Diameter N
47621	47641	7 ft. lbs.	1/2
47622	47641	20 ft. lbs.	5/8
47631	47641	7 ft. lbs.	1/2
47632	47641	20 ft. lbs.	5/8
47671	47641	10 N•m	13 mm
47672	47641	25 N•m	16 mm
47681	47641	10 N•m	13 mm
47682	47641	25 N•m	16 mm
47625	47643	35 ft. lbs.	3/4
47626	47643	55 ft. lbs.	7/8
47633	47643	35 ft. lbs.	3/4
47634	47643	55 ft. lbs.	7/8
47675	47643	50 N•m	19 mm
47676	47643	80 N•m	22 mm
47683	47643	50 N•m	19 mm
47684	47643	80 N•m	22 mm

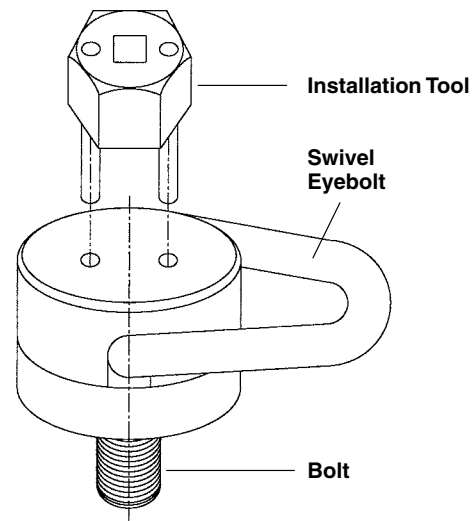



Small Swivel Eyebolt

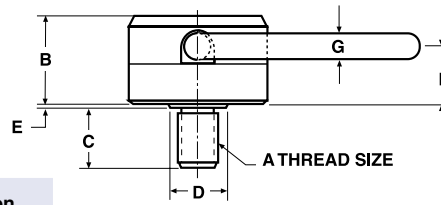
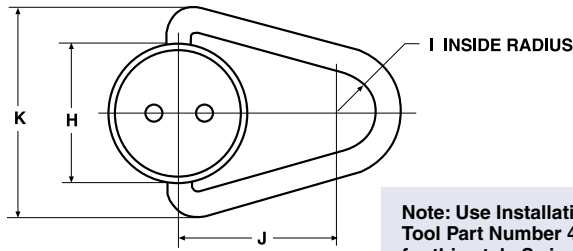

Note: Use Installation Tool Part Number 47641 for this style Swivel Eyebolt on page 18.



To add Lift ID™ to Hoist Ring Add "F" to the end of the part number Example: 23414F

Swivel Eyebolt

Part Number		Load Capacity (lbs)		Thread Size A	B	C	D	E	F	G	H	I	J	K
Alloy Steel	Stainless Steel	Alloy Steel	Stainless Steel											
47621	47631	1000	500	3/8 - 16	1 3/32	9/16	3/4	3/64	45/64	5/16	1 3/4	1/2	2	2 5/8
47622	47632	2000	1000	1/2 - 13	1 3/32	3/4	3/4	3/64	45/64	5/16	1 3/4	1/2	2	2 5/8

Metric Swivel Eyebolt

Part Number		Load Capacity (Kg)		Thread Size A	B	C	D	E	F	G	H	I	J	K
Alloy Steel	Stainless Steel	Alloy Steel	Stainless Steel											
47671	47681	500	250	M10 x 1.5	27.8	14.6	19.1	1.2	17.9	7.9	44.5	12.7	50.8	66.7
47672	47682	700	350	M12 x 1.75	27.8	19.1	19.1	1.2	17.9	7.9	44.5	12.7	50.8	66.7

Large Swivel Eyebolt

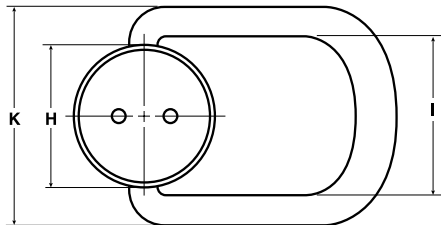

Note: Use Installation Tool Part Number 47643 for this style Swivel Eyebolt on page 18.

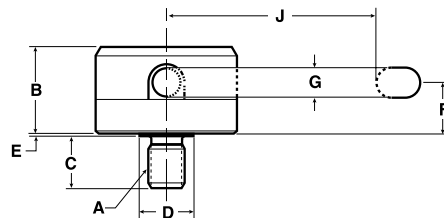

To add Lift ID™ to Hoist Ring Add "F" to the end of the part number Example: 23414F

Swivel Eyebolt

Part Number		Load Capacity (lbs)		Thread Size A	B	C	D	E	F	G	H	I	J	K
Alloy Steel	Stainless Steel	Alloy Steel	Stainless Steel											
47625	47633	3000	1500	5/8 - 11	1 33/64	15/16	7/8	1/32	57/64	1/2	2 1/2	2 3/4	3 1/2	3 13/16
47626	47634	4000	2000	3/4 - 10	1 33/64	1 1/8	1	1/32	57/64	1/2	2 1/2	2 3/4	3 1/2	3 13/16

Metric Swivel Eyebolt

Part Number		Load Capacity (Kg)		Thread Size A	B	C	D	E	F	G	H	I	J	K
Alloy Steel	Stainless Steel	Alloy Steel	Stainless Steel											
47675	47683	1500	750	M16 x 2.0	38.5	23.8	22.2	.8	22.6	12.7	63.5	70	93	97
47676	47684	2000	1000	M20 x 2.5	38.5	30.2	25.4	.8	22.6	12.7	63.5	70	93	97



Pivoting Lift Ring



The Jergens Pivoting Lift Ring is a low profile lifting device that pivots 180°. It is one of the most economical lifting devices available and is ideal for applications that do not require a swivel action. This Lift Ring is easy to install and is available in five sizes. Load ratings range from 2,000 - 20,000 lbs. The product is manufactured from alloy steel, heat treated and magnafluxed.

- Base: Precision Machined Alloy Steel
- Ring: Alloy Steel forging, heat treated, magnafluxed and certified
- Finish: Black Oxide
- Rated at 6:1 Strength Factor
- 3D Solid Models available in multiple formats from www.jergensinc.com

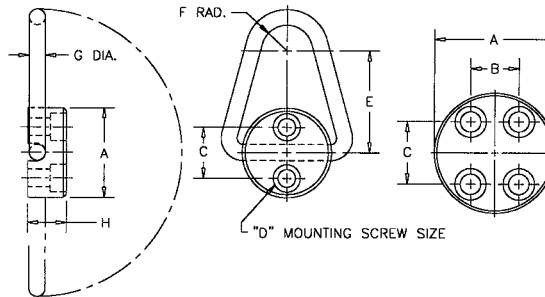

Pivoting Lift Rings

Ring Part Number	Load Capacity (lbs)	A	B	C	Mounting Bolt Part Number	Thread & Length D	E	F	G	H
47411	2000	1 3/4	-	1	47421	5/16-18 x 1 1/4	2	1/2	5/16	3/4
47412	2500	2 1/4	-	1 1/8	47422	3/8-16 x 1 1/2	2 1/2	5/8	3/8	7/8
47413	5000	2 1/2	-	1 1/2	47423	1/2-13 x 1 3/4	3	3/4	1/2	1 1/8
47414*	12000	3 1/8	1 1/4	1 5/8	47424	1/2-13 x 2 1/2	4	7/8	3/4	1 3/8
47415*	20000	3 5/8	1 1/4	2 1/16	47425	5/8-11 x 2 1/2	5	1	1	1 7/8

* The larger load capacity rings have four mounting holes.

*Note: Mounting Bolts must be ordered separately.

Metric Pivoting Lift Rings

Ring Part Number	Part Number with Pull Test & Metric Screws	Load Capacity (kg)	A	B	C	Mounting Bolt Part Number	Thread & Length D	E	F	G	H
47411	47411-PTMS	900	45	-	25.4	47471	M 8 x 1.25 x 35 mm	51	13	8	19
47412	47412-PTMS	1100	57	-	28.6	47472	M 10 x 1.5 x 40 mm	64	16	10	22
47413	47413-PTMS	2250	64	-	38.1	47473	M 12 x 1.75 x 45 mm	76	19	13	29
47414*	47414-PTMS	5400	80	31.8	41.3	47474	M 12 x 1.75 x 55 mm	102	22	19	35
47415*	47415-PTMS	9000	92	31.8	52.4	47475	M 16 x 2.0 x 65 mm	127	25.4	25.4	48

* The larger load capacity rings have four mounting holes.

*Note: Mounting Bolts must be ordered separately.



Eye Nuts Inch

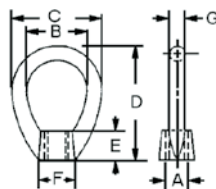

- Material: C-1030 Forge

Part Number	A	B	C	D	E	F	G	Load Wt (lbs)	Capacity (lbs)
18900*		1 1/4	2	2 1/2	5/8	7/8	3/8	.22	2700
18901	3/8-16	1 1/4	2	2 1/2	5/8	7/8	3/8	.22	2700
18902	1/2-13	1 1/4	2	2 1/2	5/8	7/8	3/8	.22	2700
18903	5/8-11	1 1/2	2 1/2	3	3/4	1 3/8	1/2	.50	5000
18904	3/4-10	1 1/2	2 1/2	3	3/4	1 3/8	1/2	.50	5000
18905*		1 1/2	2 1/2	3	3/4	1 3/8	1/2	.50	5000

*Blank

Shoulder Eye Bolts Inch

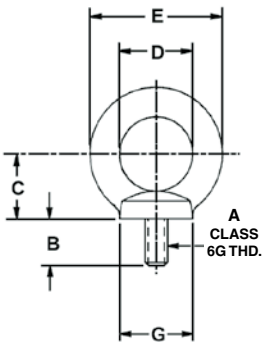
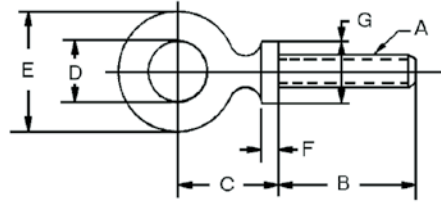

- Material: C-1030 Forge
- Finish: Mill
- Thread: 2A
- Rated at 5:1 strength factor

For other than vertical loads, general practice is to use 60% of the working load capacity for a load 30° from vertical; 33% of vertical load for load 45° from vertical; and 20% of vertical load for load 90° from vertical.

NOTE: 2 1/2 threads runout on threaded portion.

Part Number	A	B	C (Ref.)	D	E	F (Ref.)	G	Wt (lbs)	Load Capacity (lbs)
18501	1/4-20	1	11/16	3/4	1 3/16	3/16	1/2	.05	500
18502	5/16-18	1 1/8	7/8	7/8	1 7/16	3/16	5/8	.10	900
18503	3/8-16	1 1/4	1 1/16	1	1 21/32	3/16	11/16	.16	1300
18504	1/2-13	1 1/2	1 5/16	1 3/16	2 1/16	1/4	7/8	.36	2400
18505	5/8-11	1 3/4	1 19/32	1 3/8	2 1/2	1/4	1 1/8	.65	4000
18506	3/4-10	2	1 23/32	1 1/2	2 13/16	5/16	1 1/4	1.00	5000
18507	7/8-9	2 1/4	2 3/16	1 11/16	3 1/4	3/8	1 7/16	1.70	7000
18508	1-8	2 1/2	2 13/32	1 13/16	3 9/16	13/32	1 9/16	2.36	9000
18509	1 1/8-7	2 3/4	2 23/32	2	4	15/32	1 11/16	3.41	12000
18510	1 1/4-7	3	2 15/16	2 3/16	4 7/16	1/2	1 7/8	4.68	15000
18511	1 1/2-6	3 1/2	3 7/16	2 1/2	5 3/16	9/16	2 3/16	7.77	21000
18512	1 3/4-5	3 3/4	3 31/32	2 7/8	6 1/16	5/8	2 1/2	11.35	28000
18513	2-4 1/2	4	4 1/2	3 1/4	6 7/8	3/4	2 7/8	16.70	38000

Metric - Short

Loads given ensure a strength factor of four against deformation of any kind and strength factor of five against fracture.

- Material: C-15 Annealed (AISI 1015)
- Finish: Mill
- Thread: 6g

Part Number	A	B	C (Ref.)	D	E	G	Wt. (kg)	Maximum permissible loads in lbs.	
								For one bolt firmly tightened	For two bolts total
18551	M6 x 1	13.0	17.5	19.1	36.5	20.0	.023	150	100
18552	M8 x 1.25	13.0	22.2	22.2	36.5	20.0	.045	300	200
18554	M12 x 1.75	20.5	33.3	30.2	52.4	30.0	.163	700	500
18555	M16 x 2	27.0	40.5	34.9	63.5	35.0	.295	1500	1100

All Dimensions in Millimeters.

Metric - Standard

Part Number	A	B	C (Ref.)	D	E	F (Ref.)	G	Wt (lbs)	Load Capacity (kg)	Load Capacity (lbs)
18561	M6 x 1.0	25.4	20.6	19	30.0	3.9	13.5	.06	210	462
18562	M8 x 1.25	31.7	29.4	25	43.0	4.8	17.5	.17	500	1110
18563	M10 x 1.5	35.0	33.3	27	46.0	5.2	19.8	.24	740	1628
18564	M12 x 1.75	38.0	36.5	30	54.0	5.6	22.2	.36	1030	2266
18565	M16 x 2.0	44.5	43.6	35	65.0	6.3	27.0	.69	1600	3520
18566	M20 x 2.5	57.0	55.6	41	81.0	9.5	36.5	1.51	2860	6292
18567	M24 x 3.0	63.5	61.1	44	90.4	10.3	39.7	2.36	3850	8470
18568	M30 x 3.5	76.0	74.6	55	112.7	12.7	47.6	4.68	6400	14080
18569	M36 x 4.0	89.0	87.3	63	131.8	14.3	55.6	7.77	8970	19734
18570	M42 x 4.5	95.0	93.6	73	152.4	15.1	60.3	11.10	11960	26312
18571	M48 x 5.0	101.6	107.9	82	174.6	17.5	69.8	15.90	16400	36080

- Material: C-1030 Forge
- Finish: Mill
- Thread: 6g



Quality Standards Center-Pull Traditional and Side-Pull Traditional Style Hoist Rings

Load Bearing Member Components

- All material is domestically manufactured certified alloy steel.
- All components are machined prior to manufacture to remove any surface defects.
- All components are heat treated and certified to manufacturing specifications.
- Bolts are:

Inch

Socket Screw Grade
Tensile Strength
-180,000 psi - 1/2" or Smaller
-170,000 psi - Over 1/2"
100% Magnetic Particle Inspected
to ASTM E709-80

Metric

Grade 12.9
Tensile Strength
-1220 MPa
- (177,000 psi)
100% Magnetic Particle Inspected
to ASTM E709-80

- All other load bearing components are magnetic particle inspected based upon ASTM E709-80 and MIL-STD-105 with zero defects permissible.
- Bolt torque and hoist ring load limit permanently marked on washer.
- **ISO 9001: 2008 Certified**

Individual certificate of proof-test accompanies Center-Pull and Side-Pull Traditional Style hoist rings in final packaging.



MANUFACTURING EFFICIENCY

CERTIFICATE OF PROOF TEST

(1) Distinguishing Mark	(2) Description of Item Tested	(3) Quantity Tested	(4) Date Tested	(5) Load Applied	(6) Rated Load
BI	23408 HOIST RING	1	1/1/2003	2,000 LBS	1,000 LBS

(7) Name and Address of Supplier: Jergens Inc., 15700 Waterloo Rd., Cleveland, OH 44110

(8) Name and Address of Company performing test: Jergens Inc., 15700 Waterloo Rd., Cleveland, OH 44110

(9) Position of Signatory in Company: Quality Assurance Manager

Jergens Inc. certifies that all hoist rings have been proof tested and examined in accordance with Jergens QSWI 10.3D and that this test completes all procedures as required.



ISO9001:2008
QUALITY SYSTEM CERTIFIED

(Signature)



In substantial agreement with (OSHA) 29 CFR 1918, ANSI B30-26, MIL-STD-1365C, MIL-STD-209K

LIFTING SOLUTIONS » QUALITY STANDARDS



Quality Standards For Center-Pull and Side-Pull Traditional Style Hoist Rings

Assembly Data

- Traditional Center Pull and Side Pull hoist ring assemblies are pull-tested and certified to 200% of rated load capacity and stamped with identifying date code.
- All hoist rings are designed for 5:1 strength factor.
- Hoist rings are color coded for easy identification: gold washer denotes inch sizes, silver/clear blue washer denotes metric sizes.
- Finished assembly is black oxide (with the exception of the washer).
- The Jergens name or logo is prominently displayed on assembly for identification of original manufacturer.
- Special plating or marking is available upon customer's request.
- Proper warning label is affixed to each clevis.
- Proof load testing, magnafluxing and heat treating are on file at Jergens, Inc.
- Material Certs available for nominal cost and must be requested with initial order.
- The finished hoist ring product is individually boxed.

NOTE: Specifications for side pull style hoist rings are identical to center pull style with the exception that the clevis is of precision cast alloy material which is serialized and conforms to X-ray specifications.

Contact Jergens for quality standards on all other lifting products.

Multi-lingual safety data instructions included in each package

IMPORTANT
GIVE TO SAFETY MANAGER

IMPORTANT
À FOURNIR AU
DIRECTEUR DE SÉCURITÉ

IMPORTANTE
ENTREGAR AL
SUPERVISOR DE SEGURIDAD

IMPORTANTE
CONSEGNARE AL
RESPONSABILE PER LA
SICUREZZA

IMPORTANTE
DÊ PARA O GERENTE
DE SEGURANÇA

WICHTIG
AN DEN
SICHERHEITSMANAGER
WEITERGEBEN

重要
安全管理担当者様

Jergens Way • 15700 S. Waterloo Rd.
Cleveland, Ohio 44110-3898
Phone: (216) 486-5540 • Fax: (216) 481-6193

Printed in the U.S.A.
© Copyright 2011

We Are Jergens

WORKHOLDING SOLUTIONS



Support, Locate and Hold:

From standard components like toggle screws and T-bolts to vises and quick change fixture systems like Ball Lock® and ZPS.

SPECIALTY FASTENERS



Fasten, Strengthen and Release:

From threaded inserts and spinner grip nuts to Kwik-Lok® Pins.

LIFTING SOLUTIONS



Lift, Turn and Track:

From chain sling and eye bolts to hoist rings and our proprietary Lift ID™ Automated Inspection and Compliance program.

We got our start back in 1942, manufacturing tooling components to help American manufacturers operate quickly and more efficiently. “The Standard Components with the Highest Standards:” This founding philosophy put Jergens on the forefront of the “lean manufacturing” movement before anyone even thought to put those two words together.

In the years since, Jergens has structured its offering to advance the cause of leaner manufacturing, adding products and engineered solutions for an integrated approach to “Manufacturing Efficiency.”

You can find Jergens products just about anywhere in the manufacturing environment.



Jergens
MANUFACTURING EFFICIENCY

Jergens®

MANUFACTURING EFFICIENCY

WORLD HEADQUARTERS USA

15700 S. Waterloo Road, Cleveland, OH 44110-3898 USA

 +1.216.486.5540  +1.216.481.6193

+1.877.440.LIFT (5348)

 lifting@jergensinc.com

 www.jergensinc.com/lifting



WORKHOLDING
SOLUTIONS



SPECIALTY
FASTENERS



LIFTING
SOLUTIONS

DISTRIBUTED BY:

AD0311

© Copyright Jergens, Inc. 2011