



omnitrack®
omnidirectional movement



Effortless precision
SINCE 1909



Effortless precision
Since 1909



Call, email or chat online.
Free technical advice now.



No minimum order charges.
Buy what you need now.



Rapid production of
a bespoke solution
to meet your needs.



Immediate despatch from
stock & fast global delivery.



SINCE
1909

Original Patented design, tested &
manufactured in the UK since 1909.



HEAVY DUTY

Pages 4 - 7

- Low friction 0.005μ, highest loads
- Smooth & precise movement at any angle of orientation
- Material upgrade options for max life

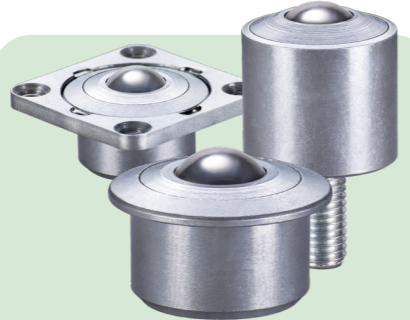

MEDIUM DUTY

Pages 12 - 15

- Robust & precision machined
- MX, MV & MW 'Air-cargo' units
- Fixing clips & tolerance rings for rapid



LIGHT DUTY

Pages 16 - 17

- Pressed steel economy range
- Nylon, POM plastic & stainless range
- Cup & ball hemisphere design



omnicaster PLASTIC CASTORS

Pages 18 - 19

- Suitable for delicate surfaces
- Fast directional change
- Self-cleaning in operation



omnifloat GLASS HANDLING

Page 20

- Glass & sheet handling
- Hard-wearing/high-heat upgrade
- Stainless steel for wet areas



omniwheel CONVEYOR ROLLERS

Pages 22 - 23

- Outdoor, dusty & washdown use
- Gravity, driven & bearing hubs
- Powered & driven conveying



SPRING LOADED

Pages 8 - 9

- Low friction, highest shock remittance
- Inverted orientation operation
- Pre-loaded spring deflection & die lifters

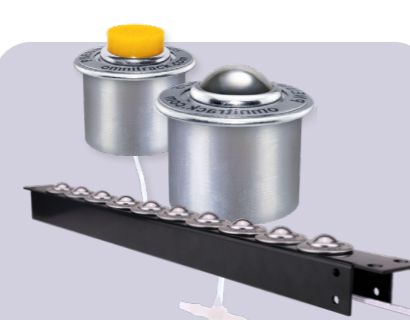

PNEUMATIC

Pages 10 - 11

- Pop-up ball units, stops, wheels & rails
- Modular live/dead control flexibility
- Installation tubing, regulators & ancillaries

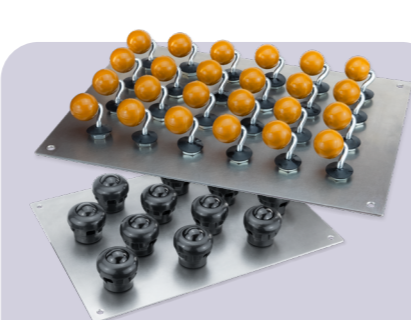

BALL TABLES & PLATFORMS

Page 24 - 25

- Configure your ideal conveying plane
- Standard sizes dispatched from stock
- Custom built tables & platforms



BALL RAILS

Page 26

- Chrome steel, stainless or POM ball units
- Bolt together or interlink with spacer tubes
- Adjustable 'bolt down' fixing brackets

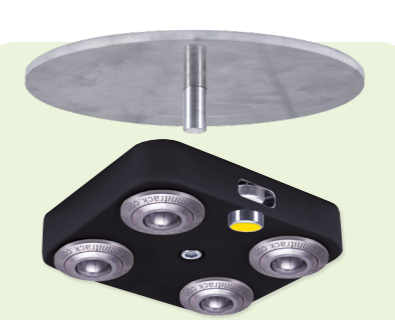

BALL SKATES

Page 27

- Move equipment, shelving & machinery
- Low profile & fits standard shelf legs
- Parking brake & optional load plate

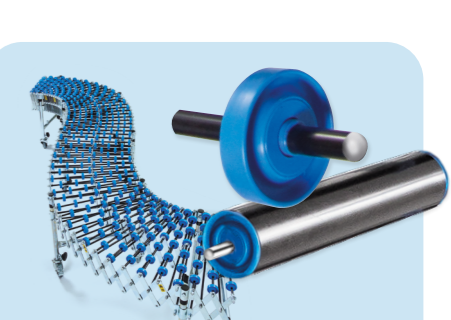

FLEXIBLE CONVEYORS

Page 21

- Negotiate bends-mobile expandable concertina
- Skatewheel & gravity roller conveyor options
- Adjustable working height



- 8000 KG**
Maximum load rating unaffected at any orientation
- μ**
Low friction 1 : 0,005
- High Shock Resistance**
- Temperature -50/260°C**
- Speed 2m/sec**
- Drain / Debris Channels**
9000 Series only
- User Serviceable**
9000 Series only
- Precision Machined Construction**

- Felt seal**
9000 Series only
- Lubricant**
Mobil Vactra 1 Oil
- A & Standard**
Single Drain Channel
- Z & SS**
2 x Drain Channels

80 & 90 Series - PLAIN FIT A Z SS PB

Fixing Options Page 15

8020, 8030 & 8040 only			
PART	D Ø	E (X3)	F X PITCH
8020	16	6	M4 x 0.7
8030	20	6	M5 x 0.8
8040	26	8	M6 x 1.0

PART	LOAD (kg)	BALL Ø (mm)	A	B	C
8000	50	12.7	20	20	3.8
8001	50	12.7	20.6	19.1*	3.8
8010	50	12.7	22.2	22.1	3.8
8020	90	15.8	24	29	5
8030	125	19.1	30	34	6
8040	180	25.4	38	45	8
9020	225	25.4	44	41.3	5.6
9021	225	25.4	44.5	41.3	5.6
9022	225	25.4	44.5	41.3	7.1
9030	385	25.4	50	44.5	6.4
9031	385	25.4	50.8	44.5	6.4
9040	1100	38.1	60	61.5	12.7
9041	1100	38.1	60.3	61.5	12.7
9042	1100	38.1	60.3	60.3	12.7
9050	2200	50.8	100	95	14.3
9051	2200	50.8	101.6	98.4	14.3
9060	4550	76.2	160	145	21
9070	8000	101.6	228	190	38

* 9001 - spigot 3.2mm x 8mm Ø
Further 1.5mm @ 16.2mm Ø

STANDARD MATERIALS: AISI 52100 high chrome steel balls & internal load bearing components. "Anti-Oxide" electrophoretic coating (>350 hours ISO salt resistance) of precision machined steel housing.

Solve specific application requirements by upgrading standard materials. Select option below by adding suffix:

	Corrosion	Contamination	Temperature	Radiation
A	✓	✓	✓	✓
Z	✓✓	✓✓	✓✓	✓
SS	✓✓	✓✓	✓✓	✓✓

Option	Description	Corrosion	Contamination	Temperature	Radiation
A	STAINLESS STEEL BALLS UPGRADE AISI 440C stainless steel balls, internal components as standard. "Anti-Oxide" housing. Load rating as standard & remains unaffected.	✓	✓	✓	✓
Z	ARDUOUS CONDITIONS UPGRADE AISI440C stainless steel balls & load-bearing internal components. "Anti-Oxide" outer housing. Load rating as standard & remains unaffected.	✓✓	✓✓	✓✓	✓
SS	ALL STAINLESS STEEL UPGRADE AISI440C stainless steel balls & load-bearing internal components. AISI 304 outer housing. Load rating as standard & remains unaffected.	✓✓	✓✓	✓✓	✓✓

PB PHENOLIC RESIN BALL OPTION
Minimise marking of delicate surfaces. Friction, wear & temperature properties change - consult us if in doubt. Reduced load ratings indicated.

BALL Ø (mm)	12.7	25.4	38.1+
PB LOAD (kg)	10	30	38

PART	LOAD (kg)	BALL Ø (mm)	A	B	C	D	E	F
8100	50	12.7	20	19.1	3.8*	16.1	-	M8 x 1.25
8101	50	12.7	20.6	19.1	3.8*	28.7	-	M8 x 1.25
8102	90	12.7	20.6	19.1	3.8*	28.7	-	5/16" UNF
8112	50	12.7	22.2	22.2	3.8*	25.4	-	5/16" UNF
8120	90	15.8	24AF/27.7Ø	26	5	20	-	M12 x 1.75
8130	125	19.1	30AF/34.9Ø	31	6	25	-	M16 x 2.0
8140	180	25.4	38AF/43.9Ø	42	8	30	-	M20 x 2.5
9120	225	25.4	44	48.3	5.6	25	-	M12 x 1.75
9123	225	25.4	44	47.3	5.6	25	6	M12 x 1.75
9124	225	25.4	44.5	47.3	7.1	25.4	6	1/2" UNF
9130	385	25.4	50	51.3	6.4	25	-	M12 x 1.75
9133	385	25.4	50	50.5	6.4	25	6	M12 x 1.75
9134	385	25.4	50.8	50.5	6.4	25.4	6	1/2" UNF
9135	385	25.4	50.8	42	6.4	60	10	1" UNF
9140	1100	38.1	60	73.5	12.7	40	-	M20 x 2.5
9143	1100	38.1	60	71.5	12.7	40	10	M20 x 2.5
9144	1100	38.1	60.3	71.5	12.7	38.1	10	3/4" UNF
9145	1100	38.1	60.3	60	12.7	75	6	1" UNF
9150	2200	50.8	100	105	14.3	54	-	M24 x 3.0
9153	2200	50.8	100	109	14.3	50	10.6	M24 x 3.0
9154	2200	50.8	101.6	109	14.3	50.8	10.6	1" UNF
9160	4550	76.2	160	145	21	57.2	-	1" UNF
9163	4550	76.2	160	145	21	100	15	M30 x 3.5

* Further 1.5mm @ 16.2mm Ø
81 & 91 Series units omit drain/debris channel - contact us if required

81 & 91 Series THREADED STUD A Z SS PB

8120, 8130 & 8140 HEXAGON BODY
81 & 91 Series ENDING 0, 1, 2 & 5
91 Series ENDING 3 & 4

81 & 91 Series ENDING 0, 1, 2 & 5 & HEXAGON BODY
91 Series ENDING 3 & 4

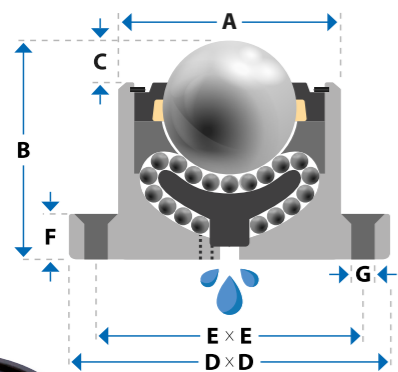

82 & 92 Series - FLANGE MOUNTED A Z SS PB

PART	LOAD (kg)	BALL Ø (mm)	A	B	C	DXDØ	EXE	F	GØ
8200	50	12.7	23.8	22.2	3.8*	44.5	34.9	3.2	2 x 3.6
8210	50	12.7	23.8	22.2	3.8*	47.7 x 32+	34.9	2	2 x 4
8220	90	15.8	24	29	5	40	32	4	4 x 4.5
8230	125	19.1	30	34	6	50	40	5	4 x 5.5
8240	180	25.4	38	45	8	60	49	6	4 x 6.5
9220	225	25.4	44	41.3	5.6	57.2	44.5	4.8	4 x 6.1
9221	225	25.4	44.5	41.3	7.1	57.2	44.5	4.8	4 x 6.1
9230	385	25.4	50	44.5	6.4	76.2	57.9	6.4	4 x 8.1
9240	1100	38.1	60	61.5	12.7	76.2	57.9	12.7	4 x 8.1
9241	1100	38.1	60.3	60.3	12.7	76.2	57.9	12.7	4 x 8.1
9250	2200	50.8	100	98.4	14.3	127	101.6	9.5	4 x 11.1
9260	4550	76.2	160	145	21	175	145	15	4 x 13.1
9270	8000	101.6	228	190	38.1	235	190.5	25	4 x 16.1

A Circular flange
Z Further 1.5mm @ 16.2mm Ø
SS 8210 - Elliptical flange
PB Not countersunk

83 & 93 Series - FLANGE SOCKET MOUNTED A Z SS PB

PART	LOAD (kg)	BALL Ø (mm)	A	B	C	DXDØ	EXE	F	GØ
8300	50	12.7	23.8	22.2	11.2	44.5	34.9	3.2	2 x 3.6
8310	50	12.7	23.8	22.2	7.9	47.7 x 32+	34.9	2	2 x 4
8320	90	15.8	24	29	11	40	32	6	2 x 4.5
8330	125	19.1	30	34	13	50	40	7	2 x 5.5
8340	180	25.4	38	45	16	60	49	8	2 x 6.5
9320	225	25.4	44	41.3	10.3	57.2	44.5	4.8	4 x 6.1
9321	225	25.4	44.5	41.3	11.9	57.2	44.5	4.8	4 x 6.1
9330	385	25.4	50	44.5	12.7	76.2	57.9	6.4	4 x 8.1
9341	1100	38.1	60	60	25.4	76.2	57.9	12.7	4 x 8.1
9350	2200	50.8	100	95	33.3	127	101.6	19.1	4 x 11.1
9351	2200	50.8	101.6	98.4	36.5	127	101.6	22.2	4 x 11.1
9352	2200	50.8	109.5	98.4	33.3	127	101.6	19.1	4 x 10.3
9360	4550	76.2	160	145	36	175	145	15	4 x 13.1

A Circular flange
Z Counterbore
SS 8310 - Elliptical flange
PB Not countersunk

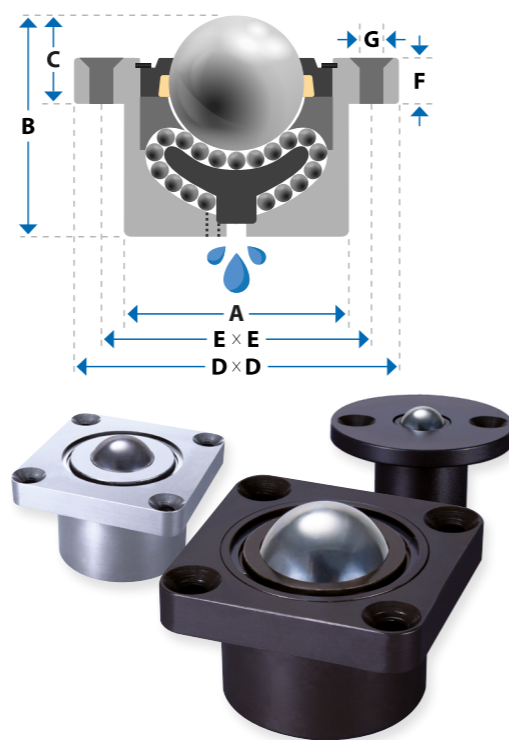

88 & 98 Series - TOLERANCE RING A Z SS PB

PART	LOAD (kg)	BALL Ø (mm)	A	B	C	D	E	F
8810	50	12.7	22	12	6	21	24	2.4
9820	225	25.4	45*	15	14	40	49	6.9
9830	385	25.4	50*	16	15	44	55	8.6
9840	1100	38.1	65*	20	25	60	70	12.3
9850	2200	50.8	100*	24	30	95	110	15.7

* Bore Ø ISO H9 fit

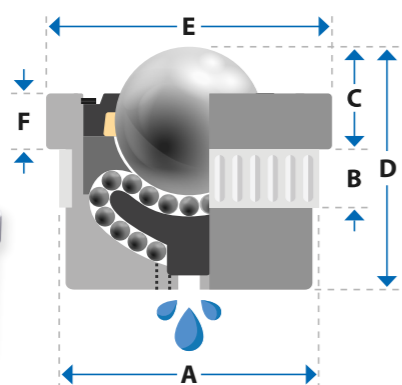

Spares & Service Kits

Omnitrack Heavy Duty 9000 series ball transfers - In continuous production since 1954.

Rapidly restore performance within minutes by using Service Kits S1 & S2 offering 2 levels of components & full overhaul instructions.

Factory reconditioning service for spring loaded & custom units as these may require special tooling for safe disassembly.

To order state original part number, any identification mark & Service Kit required eg S1-9241. If in doubt, contact us & we'll keep you rolling!

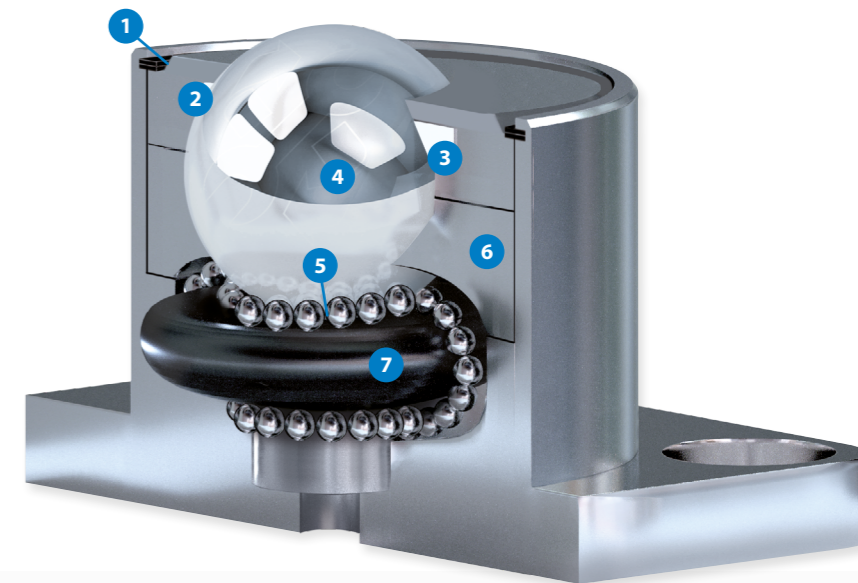

DISMANTLE

ASSEMBLE

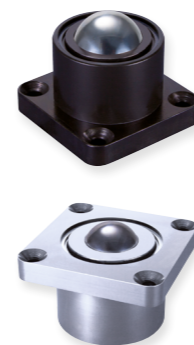

Anti-oxide Electrophoretic black finish

> 330 hours ISO salt resistance

Stainless Steel Units

- natural finish



Replacement felt seals

9000 Series only
S1 & S2 Kits

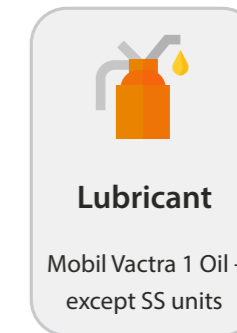

Lubricant

Mobil Vactra 1 Oil -
except SS units

Component materials & corrosion resistance

	1	2	3	4	5	6
SS 'All Stainless steel'	1	1	1	2	3	3
Z 'Arduous Conditions'	4	4	1	5	3	3
A 'Stainless steel balls, other materials as standard'	4	4	6	5	3	6
Standard Materials	4	4	6	5	6	6

- 1 AISI 304 stainless steel
- 2 AISI 302 stainless steel
- 3 AISI 440 stainless steel
- 4 AISI 1050 'Anti-oxide' finish
- 5 AISI 1070 carbon steel
- 6 AISI 52100 chrome steel

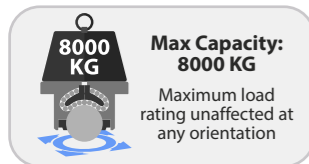

STANDARD MATERIALS: AISI 52100 high chrome steel balls & Anti-Oxide electrophoretic coated machined steel housing. Spring mechanism parts in carbon spring steel irrespective of material upgrade options below.

Solve specific application requirements by upgrading standard materials. Select option below by adding suffix:

	Corrosion	Contamination	Temperature	Radiation
A STAINLESS STEEL BALLS UPGRADE: AISI 440C stainless steel balls, internal components as standard. "Anti-Oxide" housing. Load rating as standard & remains unaffected.	✓	✓	✓	✓
Z ARDUOUS CONDITIONS UPGRADE: AISI440C stainless steel balls & load-bearing internal components. "Anti-Oxide" outer housing. Load ratings & spring values as standard & remain unaffected.	✓✓	✓✓	✓✓	✓
SS ALL STAINLESS STEEL UPGRADE: AISI440C stainless steel balls & load-bearing internal components. AISI 304 outer housing. Load ratings & spring values as standard & remain unaffected.	✓✓✓	✓✓✓	✓✓✓	✓✓✓

84 & 94 Series - EXTERNAL SPRING LOADED A Z SS

PART	BALL Ø (mm)	PRE-LOAD (kg)	MAX DE-FLECTION ADVISED	LOAD AT MAX DEFECTION (kg)	A	B	C	D	E	FIXING HOLES (PCD)	G
8401	12.7	7	2	32	20.6	32.2	47.0	14.7	20	-	3.8*
8402	12.7	14	2	35	20.6	31.8	47.0	14.7	20	-	3.8*
8403	12.7	23	2	38	20.6	32.2	47.0	14.7	20	-	3.8*
8404	12.7	23	2	38	20	32.2	47.0	14.7	20	-	3.8*
8410	12.7	7	2	32	22.2	39	47.0	14.7	20	-	3.8*
8411	12.7	14	2	35	22.2	38.6	47.0	14.7	20	-	3.8*
8412	12.7	23	2	38	22.2	39	47.0	14.7	20	-	3.8*
9420	25.4	7	5.4	136	44.5	61.9	77	19.2	31.8	3 x M5 (24.8)	5.6
9421	25.4	23	5	136	44.5	61.5	77	19.2	31.8	3 x M5 (24.8)	5.6
9422	25.4	45	4.4	136	44.5	60.9	77	19.2	31.8	3 x M5 (24.8)	5.6
9423	25.4	68	5.3	136	44.5	61.8	77	19.2	31.8	3 x M5 (24.8)	5.6
9424	25.4	89	2.7	204	44.5	61.5	77	19.2	31.8	3 x M5 (24.8)	5.6
9425	25.4	109	2.6	204	44	63	77	19.2	31.8	3 x M5 (24.8)	5.6
9430	25.4	91	7.7	331	50.8	80.8	95.3	19.2	38.1	3 x M6 (29)	6.4
9431	25.4	136	6.5	331	50.8	79.6	95.3	19.2	38.1	3 x M6 (29)	6.4
9432	25.4	181	5.8	331	50.8	80.5	95.3	19.2	38.1	3 x M6 (29)	6.4
9433	25.4	227	4.6	331	50.8	81	95.3	19.2	38.1	3 x M6 (29)	6.4
9440	38.1	227	10.5	960	60.3	115	162.1	35	59.4	3 x M6 (50.8)	12.7
9441	38.1	318	11.1	960	60.3	121	162.1	35	59.4	3 x M6 (50.8)	12.7
9442	38.1	454	11.1	960	60.3	129.2	162.1	35	59.4	3 x M6 (50.8)	12.7
9443	38.1	567	8.8	960	60.3	126.9	162.1	35	59.4	3 x M6 (50.8)	12.7
9444	38.1	680	9.2	960	60.3	146.3	189.7	35	59.4	3 x M6 (50.8)	12.7
9445	38.1	748	8.2	960	60.3	156.2	189.7	35	59.4	3 x M6 (50.8)	12.7
9450	50.8	764	2	1400	101.6	139.1	160.3	50.8	101.6	4 x M8 (76.2)	14.3
9451	50.8	764	5.3	1400	101.6	175.1	200.9	57	101.6	4 x M8 (76.2)	14.3
9452	50.8	1018	6	1400	101.6	177.4	200.9	57	101.6	4 x M8 (76.2)	14.3
9453	50.8	1273	5.9	1800	101.6	174.6	200.9	57	101.6	4 x M8 (76.2)	14.3
9454	50.8	1364	2.5	2000	101.6	137	158.4	50.8	101.6	4 x M8 (76.2)	14.3
9455	50.8	1527	5.7	2036	101.6	171.5	200.9	57	101.6	4 x M8 (76.2)	14.3

* Further 1.5mm @ 16.2mm Ø

T-Bars & B-Bars A SS

T & B bars incorporate Heavy Duty spring-loaded ball units for accurate positioning & effortless conveying of tools & dies on press & machine beds. Once positioned, clamp the tool & the springs allow the ball units to retract beneath the bed. Unclamp & the ball units will raise the tool above the bed ready to convey again. T-Bars feature an integral locking mechanism. B-Bars are locked using recessed M8 cap screw (requires drilling & tapping of the bed). Custom sizes available.

BAR	A	B	C	D	BAR LENGTH (mm)	SUPPORTS LOAD / BAR (kg)	DEFLECTION (mm)	LOAD AT MAX DEFECTION (kg)	BALL / BAR
T-20	20	34	10	35	300	224	2.6	352	8
T-22	22	37	16	38	343	252	2.6	396	9
T-24	24	42	18	42	415	280	2.6	440	10
T-28	28	46	20	48	305	308	2.6	484	11
T-36	36	56	25	61	345	252	2.6	396	9
B-21	20.6	-	-	25.4	250	168	2.6	264	6
B-22	22.2	-	-	30.1	395	224	2.6	352	8
B-25	25.4	-	-	38.1	350	305	2.6	484	11

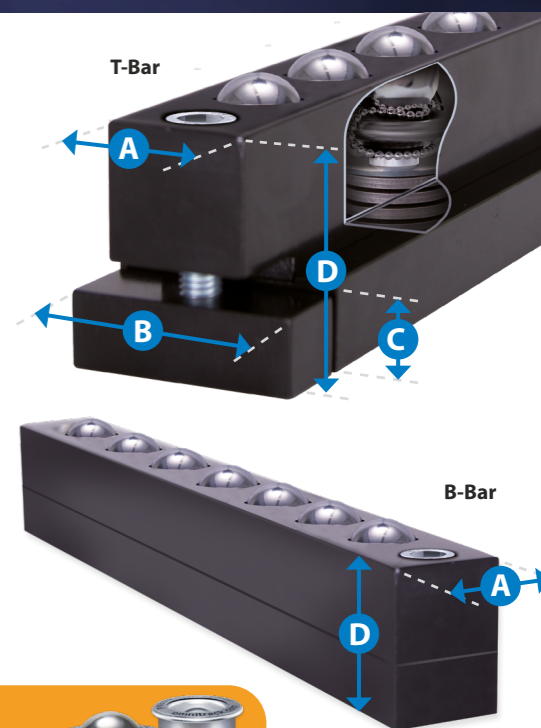

Spring Loaded Ball Transfers A Z SS

Omnitrack Heavy Duty spring loaded units are ideal where uneven track conditions or shock loading occurs. Internal springs offer full retraction of the ball within the housing. We can tailor spring pre-loads, deflections & characteristics to your requirements. Consider alternative material upgrade options to withstand severe operating environments.



85 & 95 Series - HOUSED SPRING LOADED A Z SS

PART	SUPPORTS LOAD (kg)	DEFLECTION (mm)	LOAD AT MAX DEFECTION (kg)	BALL Ø (mm)	A	B
8500	23	2.2	38	12.7	25.4*	25.4
8501	12	3.3	46	12.7	25.4*	25.4
9520	91	4.8	188	25.4	50.8	55.5
9530	227	2.4	367	25.4	63.5	60.3
9540	450	10	960	38.1	69.9	114.3
9550	1000	6.1	2000	50.8	120	138.9

* 8mm wide (fine) knurl on outside Ø



86 & 96 Series - FLANGE SOCKET SPRING LOADED A Z SS

PART	SUPPORTS LOAD (kg)	DEFLECTION (mm)	LOAD AT MAX DEFECTION (kg)	BALL Ø (mm)	A	B	C	D	E (PCD)	F Counter-sunk
8601	12	3.3	46	12.7	25.4	25.4	5	50	36	2 x 5.1
9620	91	4.8	188	25.4	50.8	55.5	6	80	65	3 x 6.1
9630	227	2.4	367	25.4	63.5	60.3	6	100	80	3 x 8.1
9640	450	10	960	38.1	69.9	114.3	10	115	92	3 x 10.1
9650	1000	6.1	2000	50.8	120	138.9	12	165	140	3 x 10.1



87 & 97 Series - FLANGE MOUNTED SPRING LOADED A Z SS

PART	SUPPORTS LOAD (kg)	DEFLECTION (mm)	LOAD AT MAX DEFECTION (kg)	BALL Ø (mm)	A	B	C	D	E (PCD)	F Counter-sunk
8701	12	3.3	46	12.7	25.4	25.4	5	50	36	2 x 5.1
9720	91	4.8	188	25.4	50.8	55.5	6	80	65	3 x 6.1
9730	227	2.4	367	25.4	63.5	60.3	6	100	80	3 x 8.1
9740	450	10	960	38.1	69.9	114.3	10	115	92	3 x 10.1
9750	1000	6.1	2000	50.8	120	138.9	12	165	140	3 x 10.1



Pneumatic Ball Transfers, Stops & Linear Rollers

Pneumatic Ball Units allow air-driven positioning of omnidirectional ball transfers & may be individually arranged for a flexible, modular conveying plane.

PS25 Positioning Stops are pneumatically activated to stop & hold the position of the conveyed item.

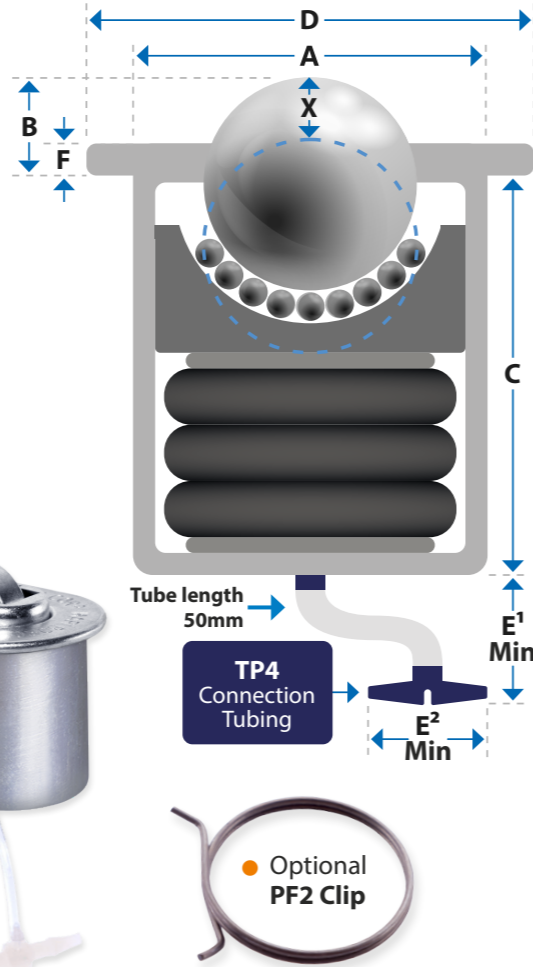

Units rated with a maximum air supply pressure of ≤ 3.4 bar support loads of up to 250 Kgs/rail whilst those rated at ≤ 6 bar air supply support up to 2500 Kgs/rail.

PART	LIFT (kg)	BAR	A	B	C	D	E ¹ MIN	E ² MIN	F	G	H	X
PB25	25	3.4	39.7	12	31.9	47	15	37	2.54			9.5
PS25	9	3.4	39.7	13.7	31.9	47	15	37	2.54			11.1
PW25	30	3.4	45.2 x 30.5 *	12	31.9	53.4 x 38.9 *	15	37	2.54			9.5
PB625	35	6	40	12.1	58	50	21	37	2.5	2 x 4.2Ø	18	9.6
PB525	35	6	40	-	58	42	21	37	-	@ 34 PCD	20	9.6

* Oval Stainless steel balls - add suffix 'A' Delrin (POM) ball option - add suffix 'D'

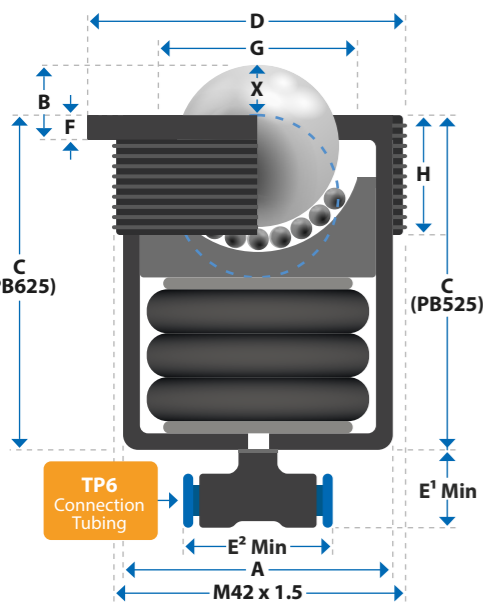

Rails

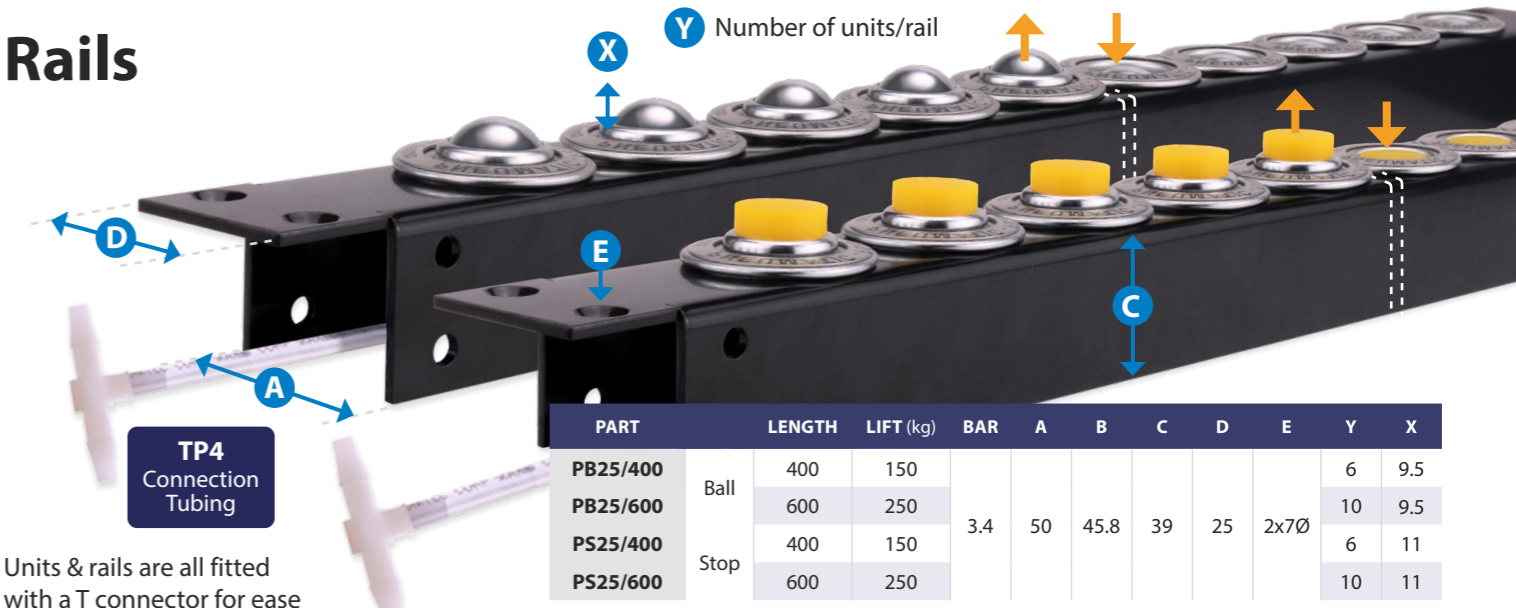

PART	LENGTH	LIFT (kg)	BAR	A	B	C	D	E	Y	X
PB25/400	400	150	3.4	50	45.8	39	25	2x7Ø	6	9.5
PB25/600	600	250							10	9.5
PS25/400	400	150	6	50	45.8	39	25	2x7Ø	6	11
PS25/600	600	250							10	11

Units & rails are all fitted with a T connector for ease of integration. High & low pressure tubing, connectors & end-plugs. Configure together with switches & regulators to provide versatile control.

In low pressure systems, tubing length should be extended or altered using optional in-line connectors (TC4) as the tubing & fittings are not designed to be separated once assembled.

Appropriate blanking plugs are automatically supplied with each order.

Alternative ball materials & sizes available.

PART	LENGTH	LIFT (kg)	BAR	A	B	C	D	X	Y
PB22 & PW22/300	300	390	6	21.5	38	37.5	15	3.5	7
PB22 & PW22/600	600	780							15
PB22 & PW22/800	800	1040							20
PB22 & PW22/1000	1000	1300						25	
PB28 & PW28/300	300	510	6	27	47	45	16	4	7
PB28 & PW28/600	600	1020							15
PB28 & PW28/800	800	1360							20
PB28 & PW28/1000	1000	1700						25	
PB36 & PW36/300	300	750	6	32	57	57	20	4.5	7
PB36 & PW36/600	600	1500							15
PB36 & PW36/800	800	2000							20
PB36 & PW36/1000	1000	2500						25	

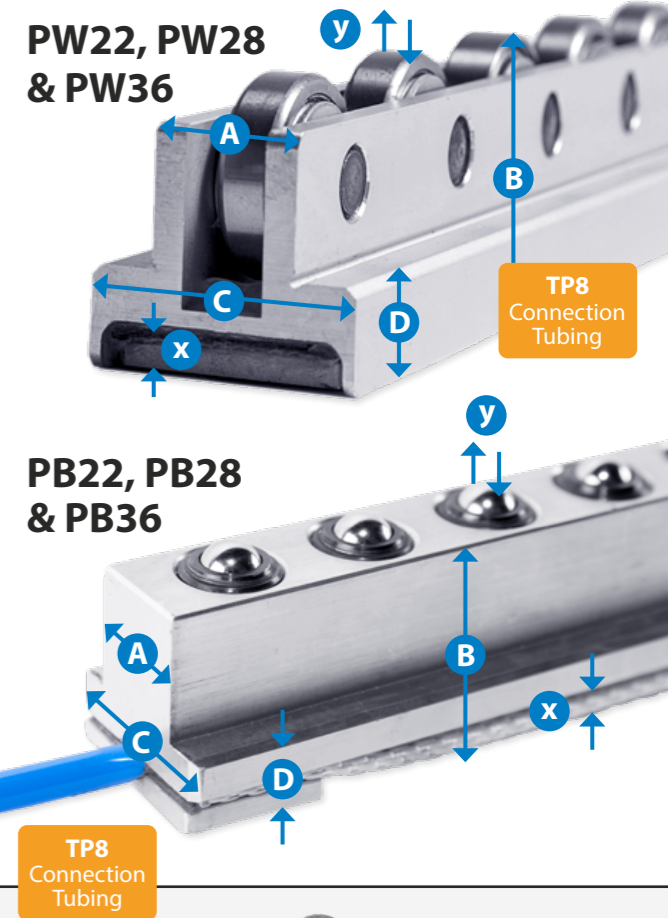

Integral Fluid Trap



Connectors & Tubing

	PART	ITEM
4 bar Low Pressure	TP4	4 bar Tubing - 3m roll
	TB4	4 bar Blanking plug
	TC4	4 bar 3-way connector
6 bar High Pressure	TP6	6 bar Tubing - 3m roll
	TP8	6 bar Tubing - 3m roll
	TB6	6 bar Blanking plug
	TC6	6 bar 3-way connector

Switches



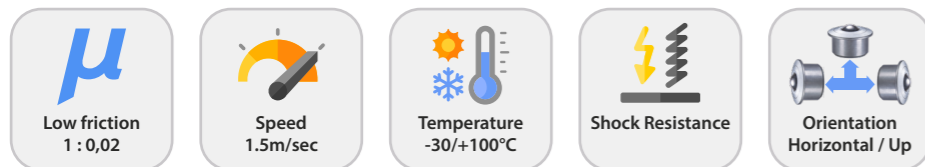

Medium Duty ball units are machined from solid steel & case hardened for wear resistance. Reinforced machined steel top cap protect against impact from misalignment of the conveyed item. Lubricated for life & zinc plated for resistance to corrosion. Standard materials; Body & cap AISI 1015, Balls AISI 52100. Stainless steel upgrade A & 'SS' feature AISI420 balls & body. Main ball sizes ≥19mm incorporate a felt seal to minimise contamination. 'M', 'MF', 'MG' & 'MS' Series feature a single drain hole.

M Series - PUSH FIT

MAXIMUM LOAD CAPACITY & NETT WEIGHT (kg)																
PART	Standard		A		D		SS		BALL Ø	A	A*	B	B*	C	D	E
	LOAD	WEIGHT	LOAD	WEIGHT	LOAD	WEIGHT	LOAD	WEIGHT								
M12 *	25	0.038	20	0.038	5	0.031	20	0.038	12	22		8		3.2	27	16.7
M14	60	0.053	50	0.053	10	0.039	50	0.051	15	24	25.0-25.5	8.1	8.4	5	30	20
M15 *	60	0.059	50	0.059	10	0.044	50	0.058	15	24	25.0-25.5	9.5	9.8	4	31	21
M22	180	0.189	180	0.188	20	0.150	126	0.188	22	36	37.0-37.2	9.8	10.1	3.8	45	30.5
M25 *	200	0.193	140	0.192	25	0.137	140	0.192	25	38		13		6	46	30.5
M30	350	0.360	350	0.357	25	0.277	220	0.357	30	45	46.3-46.7	13.8	14.01	5.8	55	36.8
M45	600	1.010	600	1.000	25	0.710	350	1.020	45	62	63.0-63.5	19	19.3	9	75	53.5
M60	1500	3.710	1100	3.820	N/A	N/A	1050	3.830	60	100		30		15	117	77.5

* Denotes pressed top cap When using K clips dimensions A & B change to A* & B*

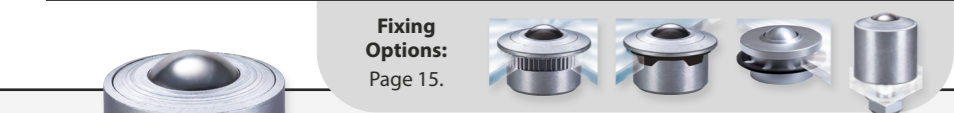

MF Series - BOTTOM FLANGE

MAXIMUM LOAD CAPACITY & NETT WEIGHT (kg)															
PART	BALL Ø	A	B	C	D	EXE	FXF	G	H	Standard		A		D	
										LOAD	WEIGHT	LOAD	WEIGHT	LOAD	WEIGHT
MF12 *	12	23.9	20.7	17.2	3.5	44.5	34.9	3.2	2 x 3.6	25	0.103	20	0.103	5	0.100
MF15	15	24	20	16	5	45	32	5.0	4 x 4.6	60	0.049	50	0.048	10	0.089
MF22	22	36	30.5	26	4.5	57.2	44.5	5.0	4 x 5.6	180	0.177	180	0.257	20	0.219
MF30	30	45	36.8	30.3	6.5	76.2	57.9	6.3	4 x 7.1	350	0.501	350	0.504	25	0.416
MF45	45	62	53.5	45	8.5	85	69	6.3	4 x 7.1	600	1.138	600	1.168	25	0.928

* Denotes pressed top cap MF12 has a 44.5mm circular flange with 2 fixing holes

MS Series - TOP FLANGE

MAXIMUM LOAD CAPACITY & NETT WEIGHT (kg)															
PART	BALL Ø	A	B	C	DXD	EXE	F	G	Standard		A		D		
									LOAD	WEIGHT	LOAD	WEIGHT	LOAD	WEIGHT	LOAD
MS12 *	12	23.9	9.6	11.1	44.5	34.9	3.2	2 x 3.6	25	0.103	20	0.100	5	0.100	
MS15	15	24	11.3	9.7	45	32	5.0	4 x 4.6	60	0.059	50	0.059	10	0.044	
MS22	22	36	11.8	18.7	57.2	44.5	5.0	4 x 5.6	180	0.189	180	0.188	20	0.150	
MS30	30	45	16.8	20	76.2	57.9	6.3	4 x 7.1	350	0.360	350	0.357	25	0.277	
MS45	45	62	22	31.5	85	69	9.5	4 x 7.1	600	1.010	600	1.000	25	0.710	

* Denotes pressed top cap MF12 has a 44.5mm circular flange with 2 fixing holes

MI Series
INTERNAL THREAD FIXING

PART	BALL Ø	A	B	C	D	E	F	MAXIMUM LOAD CAPACITY & NETT WEIGHT (kg)					
								Standard		A		D	
								LOAD	WEIGHT	LOAD	WEIGHT	LOAD	WEIGHT
MI12 *	12	22	24	20.5	3.5	M8 x 1.25	5	25	0.050	20	0.050	5	0.043
MI15	15	24	28	23	5	M8 x 1.25	8	60	0.074	50	0.074	10	0.061
MI22	22	36	40.5	36	4.5	M8 x 1.25	10	180	0.254	180	0.256	20	0.210
MI30	30	45	46.8	38.8	6.5	M8 x 1.25	10	350	0.460	350	0.450	25	0.360
MI45	45	62	63.5	50.5	9	M8 x 1.25	10	600	1.180	600	1.170	25	0.950
MI76	76.2	127	101.4	78.1	23.3	3.5" x 8 TPI NPSM	37.3	1000	6.060	1000	6.050	25	4.565

* Denotes pressed top cap MI76 only - User Serviceable

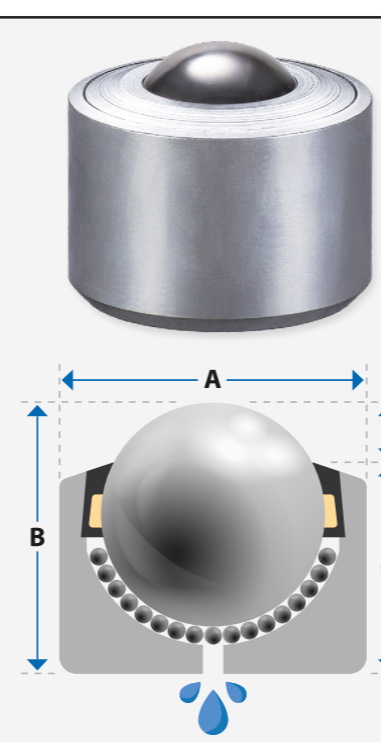
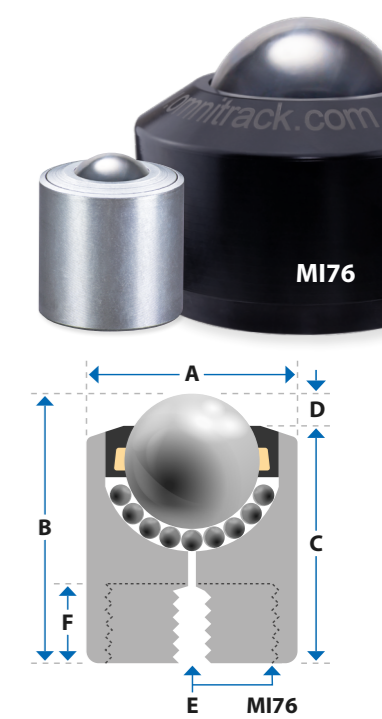

MG Series
PLAIN FITTING

PART	BALL Ø	A	B	C	D	MAXIMUM LOAD CAPACITY & NETT WEIGHT (kg)					
						Standard		A		D	
						LOAD	WEIGHT	LOAD	WEIGHT	LOAD	WEIGHT
MG8 *	8	18	12	10	2	13	0.017	10	0.018	5	0.016
MG10	10	20	16.5	13.5	3	25	0.028	20	0.028	5	0.022
MG12 *	12	22	17.5	14	3	25	0.035	20	0.034	5	0.027
MG15	15	24	20	15	5	60	0.049	50	0.048	10	0.035
MG22	22	36	30.5	26	4.5	180	0.177	180	0.178	20	0.140
MG30	30	45	36.8	30.3	6.5	350	0.335	350	0.338	25	0.250
MG45	45	62	53.5	45	9	600	0.940	600	0.97	25	0.730
MG60	60	100	77.5	61	16.5	1500	3.650	1100	3.590	N/A	N/A
MG76	76	130	103	80	23	2500	8.600	1700	8.600	N/A	N/A
MG90	90	145	115	90	25	3500	11.310	2400	11.310	N/A	N/A

* Denotes pressed top cap Dimension A changes when using fixing clips (Page 15)



MSP Series - BOLT FITTING

PART	BALL Ø	A	B	C	D	E	F	MAXIMUM LOAD CAPACITY & NETT WEIGHT (kg)					
								Standard		A		D	
								LOAD	WEIGHT	LOAD	WEIGHT	LOAD	WEIGHT
MSP8 *	8	18	27	12	2	15	M6 x 1.0	13	0.021	8	0.021	3	0.019
MSP10	12	20	29.8	17.8	3	12	M8 x 1.25	25	0.036	20	0.036	5	0.031
MSP11	12	20	48	20	3	28	M6 x 1.0	25	0.044	20	0.043	5	0.040
MSP12 *	12	22	42.5	22.5	3	20	M8 x 1.25	25	0.039	20	0.039	5	0.039
MSP14	15	24	32	20	5	12	M6 x 1.0	60	0.055	50	0.065	10	0.042
MSP15	15	25	46	26	5	20	M8 x 1.25	60	0.083	50	0.083	10	0.069
MSP19	19	30	46.5	26	4.8	20.5	M8 x 1.25	75	0.109	55	0.113	20	0.088
MSP22	22	36	62.9	37.5	4.5	25.4	M12 x 1.75	180	0.256	180	0.256	20	0.200
MSP30	30	45	69.2	43.8	6.5	25.4	M12 x 1.75	350	0.440	350	0.430	25	0.346
MSP45	45	62	107.3	66	8.5	41.3	M20 x 2.5	600	1.360	600	1.350	25	1.100

* Denotes pressed top cap



- Low friction 1:0,02
- Speed 1.5m/sec
- Temperature -30/+100°C
- Shock Resistance
- Orientation Horizontal / Up

MN / MM Series - HOUSED SPRING LOADED

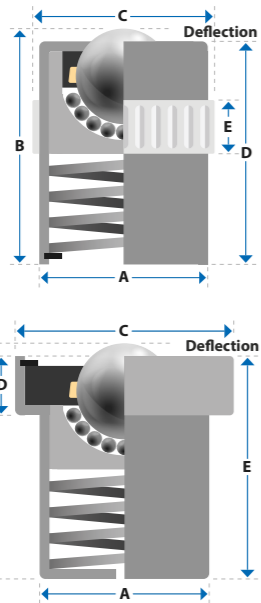

PART	SUPPORTS LOAD (kg)	DEFLECTION (mm)	LOAD AT MAX DEFLECTION (kg)	BALL Ø	A	B	C	D	E
MN12	40	1.5	90	12.7	23.9	30	24.5	28.5	10.5
MN16	60	1.5	110	15.8	29.9	36	30.5	34.5	10.5
MN25	100	1.5	175	25.4	39.8	48	40.5	46.5	10.5
MN30	335	1.5	585	30	49.9	60	50.5	58.5	12.3
MM22	70	4.5	90	22	39	58	50	14	53.5
MM30	135	7	170	30	48.5	70	62	17.5	63
MM45	230	10.5	290	45	66.5	100.5	85	25.5	90

A STAINLESS STEEL BALLS UPGRADE: Improved corrosion resistance with no change in load or spring values. Add suffix A

Alternative spring-loaded & pneumatic solutions: Pages 8 - 11.

MV, MX & MW - AIR CARGO BALL UNITS



Compliant with ISO Air cargo industry standards these units utilise stainless steel (AISI 420) balls recirculating within a precision machined Steel (AISI 1015) housing. All models feature fluid drain & omit felt seal. Consult page 15 for C-type (stainless steel) & K-type (spring steel) optional fixing clips.

SERIES	HIGH TEMPERATURE	LOAD & SHOCK	LOW NOISE	CORROSION RESISTANCE	CONSTRUCTION FEATURES
MV	✓✓	✓✓✓	✓✓✓	✓✓	E Light weight construction
MX	✓✓✓	✓✓	✓✓	✓	SS Stainless Steel
MW	✓	✓	✓	✓✓✓	SL Stainless Liner Cup

MV Imperial Series: Moulded scraper cap reduces weight & noise levels during operation. Self-cleaning multiple drain slots. Compact inch series dimensions ideal for high-density ball cargo decks.

MX Cargo Series: Steel scraper cap protects against impact damage from misaligned loads. Multiple debris/drain channels rapidly eject contamination & fluid.

MW Washdown Series: Internal stainless steel liner cup provides a cost efficient alternative to all stainless steel construction. Effective corrosion resistance & fluid draining in washdown applications. Also available in all stainless steel.

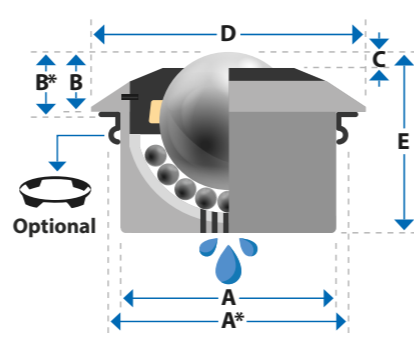
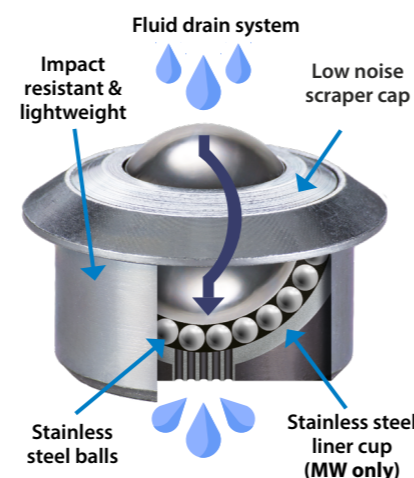

PART	LOAD (kg)	BALL Ø	WITHOUT CLIP		WITH K-TYPE CLIP			C	D	E	DRAIN CHANNELS	WEIGHT (kg)
			A	B	CLIP #	A*	B*					
MV30	350	30	45	13.8	K30	46.0 - 46.5	14.1	5.5	50	34.8	4 slots	0.290
MX30	350	30	45	13.8	K30	46.0 - 46.5	14.1	5.5	55	36.8	7 holes	0.355
MW30	220	30	45	13.8	K30	46.0 - 46.5	14.1	5.5	55	36.8	5 holes	0.337
MX45	600	45	62	19	K45	63.0 - 63.5	19.3	9	75	53.5	7 holes	1.010
MW45	450	45	62	19	K45	63.0 - 63.5	19.3	9	75	53.5	1 hole	0.960

Fixing clips change A & B values to A & B*

K & C Type Clips

- ✓ Compensate for irregularities in bore & diameter.
- ✓ Ideal where only single-sided access of mounting surface is reachable.

MEDIUM DUTY	LIGHT DUTY	CLIP	BORE Ø MIN / MAX	A
M12 MI12		K12	23 - 23.5	22
M14 M15 MI15 MG15	L15 LP15	K15 C15	25.0 - 25.5 24.8 - 25.0	24
M22 MI22 MG22	L22 LP22	K22 C22	37.0 - 37.5 37.0 - 37.2	36
M30 MI30 MG30 MV30 MX30 MW30	L30 LP30	K30 C30	46.0 - 46.5 46.3 - 46.7	45
M45 MI45 MG45 MX45 MW45	L45 LP45	K45	63.0 - 63.5	62

Clips made from Spring Steel - 0.3mm thick. The projection is increased by 0.3mm when using the clips.

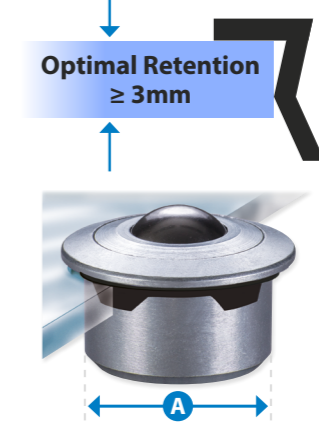

- 1 Fit clip to mounting bore.
- 2 Push ball unit through clip.
- 3 Peripheral tags expand & grip the ball unit.



Other clips available.

Tolerance Rings

- ✓ Compensate for irregularities in bore & diameter.
- ✓ Ideal where only single-sided access of mounting surface is reachable.

HEAVY DUTY	MEDIUM DUTY	LIGHT DUTY	PART	BORE Ø MIN / MAX	A	B
	MG8		TR18	19.30 - 19.55	18	6.00
8000 8001 *	MG10		TR20	21.80 - 22.05	20	12.00
8010 *	M12 MI12 MG12		TR22	23.80 - 24.05	22	12.00
8020 * 8300 * 8310 *	M14 M15 MI15 MG15	L15 LP15	TR24	25.65 - 25.90	24	15.00
8500 * 8501 * 8601 *			TR25	27.20 - 27.45	25	8.00
	M22 MI22 MG22 MM22	L22 LP22	TR36	37.80 - 38.00	36	12.00
9020 * 9021 * 9022 * 9320 * 9321 *	M30 MI30 MG30 MM30 MV30 MX30 MW30	L30 LP30	TR45	46.80 - 47.00	45	15.00
9030 9031 * 9330 9520 *			TR50	51.90 - 52.10	50	15.00
9040 9041 * 9042 * 9341	MM45		TR60	62.10 - 62.30	60	20.00
9530 *	M45 MI45 MG45 MX45 MW45	L45 LP45	TR62	64.30 - 64.50	62	20.00
9540 * 9640 *			TR70	72.35 - 72.55	70	20.00
9050 9051 * 9350	M60 MG60		TR100	103.75 - 104.05	100	20.00

Bore Ø specifications change when using Tolerance Rings. Contact us if in doubt * Ø Min / Max tolerance varies

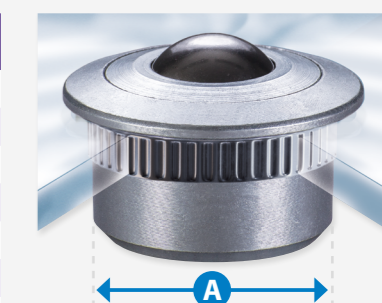

98 Series - Page 6.

Nyloc Nut & Washer + 'T' Wood Insert Kits

Use with Heavy Duty 81 & 91 series, Medium Duty MSP series & Omnicastr Ball Casters.

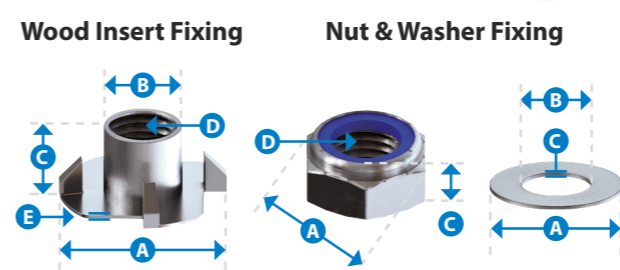

MODEL	8100 8101		OC35 OC50 OC55 OC55B		9120 9123 9130 9133				
	MSP10 MSP12 MSP15 MSP19				MSP22 MSP30				
FIXING	OC30 OC30F				OC100 OC100B				
	T8	N8	T10	N10	T12	N12			
A	22.2	14.4	16	25	18.9	20	27	21.1	24
B	9.1	13	8	11.2	17	10	14	19	12
C	11	8	1.6	13.1	10	2	14	12	2.5
D	M8 x 1.25	M8 x 1.25	M10 x 1.5	M10 x 1.5	M12 x 1.75	M12 x 1.75			
E	1.3	-	-	1.4	-	-	1.8	-	-

Other thread types & sizes available on request

Low friction
1 : 0,03

Speed
1m/sec

Temperature
-20/+80°C

Orientation
Horizontal / Up

Economy & Value

LD - SATURN TYPE

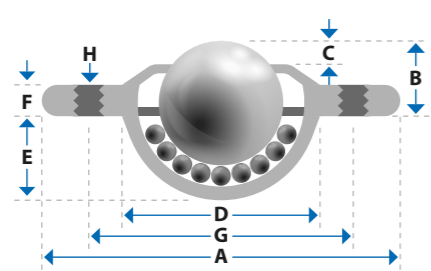

Pressed steel Saturn units are easily secured or riveted using integral fixing holes & are ideal for many light duty, low profile conveying applications. Models feature single drain hole & felt seal except LD16. LD32-SS & LD32/3-SS omit felt seal, other variants feature 7 rapid drain holes.

MAXIMUM LOAD CAPACITY & NETT WEIGHT (kg)																	
PART	BALL Ø	A	B	C	D	E	F	G	H	MAXIMUM LOAD CAPACITY & NETT WEIGHT (kg)							
										LOAD	WEIGHT	LOAD	WEIGHT	LOAD	WEIGHT	LOAD	WEIGHT
LD16	15	41	10.8	5.0	24	8.5	3.2	30	2 x 3.4	15	0.045	10	0.044	10	0.030	N/A	N/A
LD19	19	61	10	3.2	29.1	12	3.2	44.5	2 x 5.1	25	0.090	25	0.089	20	0.063	25	0.086
LD19/3	19	61	10	3.2	29.1	12	3.2	44.5	3 x 5.1	25	0.089	25	0.088	20	0.062	25	0.086
LD23	23	45	9.8	6.2	33	17.9	3.6	39	3 x 3.5	120	0.096	90	0.096	22	0.059	N/A	N/A
LD25	25.4	73	14.2	6.3	37.2	15.8	3.5	55.6	2 x 5.1	55	0.170	55	0.166	25	0.110	55	0.172
LD25/3	25.4	73	14.2	6.3	37.2	15.8	3.5	55.6	3 x 5.1	55	0.168	55	0.167	25	0.110	55	0.171
LD26	25	56	14.6	7.8	36	15.4	3.3	45	2 x 4.0	60	0.125	40	0.126	22	0.070	N/A	N/A
LD32	32	73.7	16.2	8	45.5	19.9	4.2	58.7	2 x 5.1	125	0.269	125	0.269	N/A	N/A	125	0.256
LD32/3	32	73.7	16.2	8	45.5	19.9	4.2	58.7	3 x 5.1	125	0.269	125	0.267	N/A	N/A	125	0.255

LD32-SS & LD32/3-SS units feature 7 fluid drain holes & omit felt seal

LF - FLANGE MOUNTED 2 & 4 HOLE

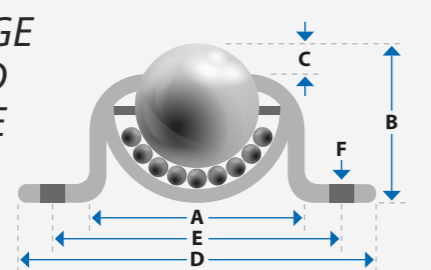

High profile, surface mounted units with fixing flange. Pressed steel construction with either 2 or 4 fixing points. LF26 units incorporate 2 slots rather than holes to accommodate varying fixing centres (55.9mm - 60.3mm). LF units feature debris drain hole. Models LF25 & LF38 omit felt seal.

MAXIMUM LOAD CAPACITY & NETT WEIGHT (kg)																	
PART	BALL Ø	A	B	C	D	E	F	MAXIMUM LOAD CAPACITY & NETT WEIGHT (kg)									
								LOAD	WEIGHT	LOAD	WEIGHT	LOAD	WEIGHT	LOAD	WEIGHT	LOAD	WEIGHT
LF25	25.4	42	30.2	7.9	69.9 x 50.8	55.6	2 x 5.6 Ø	55	0.141	N/A	N/A	N/A	N/A	N/A	N/A	N/A	N/A
LF26	25.4	45	30.4	6.3	69 x 51	55.9 - 60.3	2 x 5.5 x 7.7 mm slot	55	0.155	55	0.154	25	0.097	55	0.151		
LF38	38.1	66.9	46.2	9.8	76.2 x 76.2	62.7 x 62.7	4 x 7.1 Ø	115	0.520	N/A	N/A	N/A	N/A	N/A	N/A	N/A	N/A

LM - CASED SPRING LOADED

Load equalising spring loaded unit with integral moulded nylon seal. Internal coil spring deflects for biased loads or to compensate for surface irregularities. Carbon chrome balls & zinc plated pressings.

PART	SUPPORTS LOAD (kg)	DEFLECTION (mm)	LOAD AT MAX DEFLECTION	BALL Ø	A	B	C	D	E	NETT WEIGHT (kg)
LM25	20	4.5	55	25	43.5	49.1	25.6	10.1	15.7	0.174

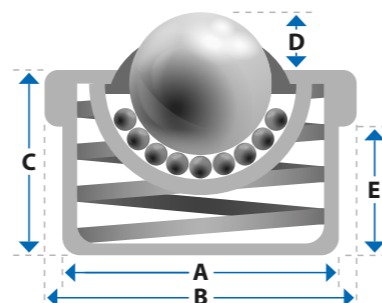

L - PUSH FIT & CLIP FIXING RANGE

Push fit retention for rapid installation & replacement where only single-sided access of mounting surface is reachable. Compensate for irregularities in seating bore diameter using optional (spring steel) K-clips, or (stainless steel) C-clips. When using optional clips dimensions 'A' & 'B' become 'A*' & 'B*'. K-clip seating bore values are shown below. See page 15 for all fixing clips & tolerance ring details.

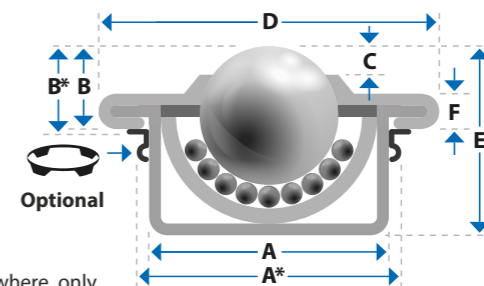

MAXIMUM LOAD CAPACITY & NETT WEIGHT (kg)															
PART	BALL Ø	A & A*	B & B*	C	D	E	F	MAXIMUM LOAD CAPACITY & NETT WEIGHT (kg)							
								LOAD	WEIGHT	LOAD	WEIGHT	LOAD	WEIGHT	LOAD	WEIGHT
L15	15	24	9.5	4.6	31	21	2.8	60	0.041	60	0.039	10	0.026	40	0.039
L15-K	15	25.0 - 25.5	9.8	4.6	31	21	2.8	60	0.041	60	0.039	10	0.026	40	0.039
L22	22	36	9.8	3.9	45	29.5	2.9	160	0.128	160	0.125	20	0.088	90	0.125
L22-K	22	37.0 - 37.5	10.1	3.9	45	29.5	2.9	160	0.128	160	0.125	20	0.088	90	0.125
L30	30	45	13.8	6.8	55	37	3.6	280	0.253	280	0.249	25	0.154	200	0.271
L30-K	30	46.0 - 46.5	14.1	6.8	55	37	3.6	280	0.253	280	0.249	25	0.154	200	0.271
L45	45	62	19	9.0	75	53.5	4.0	600	0.720	550	0.710	N/A	N/A	260	0.710
L45-K	45	63.0 - 63.5	19.3	9.0	75	53.5	4.0	600	0.720	550	0.710	N/A	N/A	260	0.710

All variants with 22mm & 30 mm main balls feature a felt seal
Values A & B change to A* & B* when using K-clips

LP - ALL PLASTIC & CLIP FIXING RANGE

Machined Acetal (POM) plastic housing fitted with either Acetal (POM) balls or AISI 316 stainless steel balls (add suffix A).

- Resists salt water & chemical attack.
- Non conductive & non magnetic.
- Suited to antimicrobial applications.

Optional fixing clips & rings - Page 15.
Spring steel K-clips & C-clips / tolerance rings in stainless steel.

MAXIMUM LOAD CAPACITY & NETT WEIGHT (kg)															
PART	BALL Ø	A & A*	B & B*	C	D	E	MAXIMUM LOAD CAPACITY & NETT WEIGHT (kg)								
							LOAD	WEIGHT	LOAD	WEIGHT	LOAD	WEIGHT	LOAD	WEIGHT	
LP15	15	24	8.0	4.8	30	20	7	0.010	7	0.027					
LP15-K	15	25.0 - 25.5	8.3	4.8	30	20	7	0.010	7	0.027					
LP22	22	36	9.8	4.5	45	30.5	10	0.035	10	0.050					
LP22-K	22	37.0 - 37.5	10.1	4.5	45	30.5	10	0.035	10	0.052					
LP30	30	45	13.8	5.8	55	37	15	0.065	15	0.174					
LP30-K	30	46.0 - 46.5	14.1	5.8	55	37	15	0.065	15	0.174					
LP45	45	62	19	8.5	75	53.5	20	0.182	20	0.500					
LP45-K	45	63.0 - 63.5	19.3	8.5	75	53.5	20	0.182	20	0.505					

Values A & B become A* & B* when using K-clips
All LP series omit felt seal

Fixing Clips K-clips spring steel C-clips stainless steel

- Compensate for irregularities in bore & diameter.
- Ideal where only single-sided access of mounting surface is reachable.

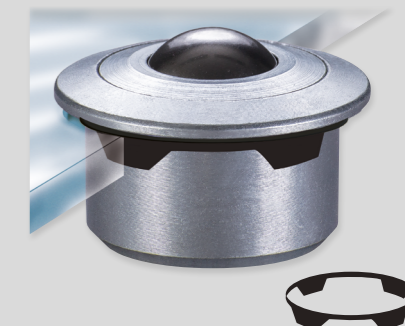

Adding suffix K or C to ball unit part number will specify supply of the optional clip (eg L22K or L22C).

When using clips, fit the clip to the bore & then push the ball unit through the clip. Peripheral tags expand & securely retain the ball unit.

Dimensions A & B change to A* & B* when using clips. Tolerance ring & full clip options shown on page 15.



- Brake Option
- Rapid Drain
- Delicate Contact
- Speed 1m/sec
- Temperature -20/+60°C

- Fast directional change - Easier steering than traditional castors.
- Glide smoothly over carpet, wood & marble floors.
- Multiple drain channels expel debris & fluids.
- Effortlessly convey delicate materials with minimal damage.

Optional Fixing Kits

Wood Insert Fixing

Nut & Washer Fixing

MODEL	OC30 OC30F			OC35 OC50 OC55 OC55B			OC100 OC100B		
FIXING	T8	N8		T10	N10		T12	N12	
A	22.2	14.4	16	25	18.9	20	27	21.1	24
B	9.1	13	8	11.2	17	10	14	19	12
C	11	8	1.6	13.1	10	2	14	12	2.5
D	M8 x 1.25	M8 x 1.25		M10 x 1.5	M10 x 1.5		M12 x 1.75	M12 x 1.75	
E	1.3	-	-	1.4	-	-	1.8	-	-

Metric dimensions subject to general tolerance of +/- 0.3mm

OC50



PART	OC50
MAX LOAD	60 kg
BALL Ø	50
A	75
B	77
C	17.8
D	44
E	25
F	M10 x 1.5

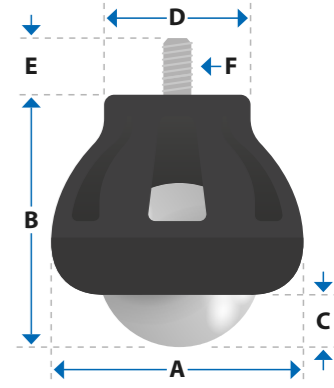

OC55 & OC55B



PART	OC55 & OC55B
MAX LOAD	60 kg
BALL Ø	50
A	76
B	84
C	14
D Ø	41.5
E	15
F	M10 x 1.5
G	34.5 (OC55)
G	26.4 (OC55B)

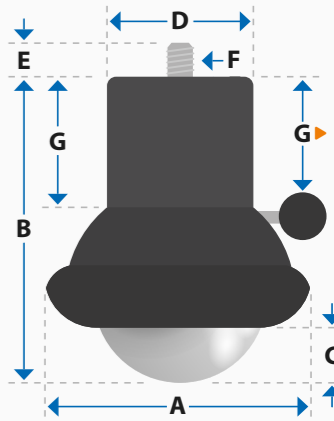

OC30 & OC30F



- Fixing Options: N8 & N10, T8 & T10
- Push Fit

PART	OC30 & OC30F*
MAX LOAD (kg)	30
BALL Ø	35
A	63.8
B / B*	53.5 / 52*
C / C*	9 / 7.5*
D / D	25 / 32
E / E	13 / 18

Values using Quick Fit adaptors
* Fixed / Non rolling caster

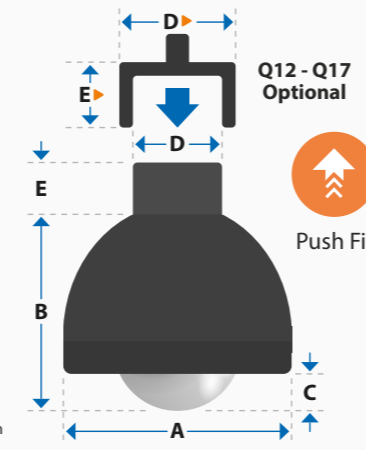

Quick Fit Adaptors

OC35



PART	OC35
MAX LOAD (kg)	30
BALL Ø	35
A	60
B	60
C	9.6
D Ø	44
E	25
F	M10 x 1.5

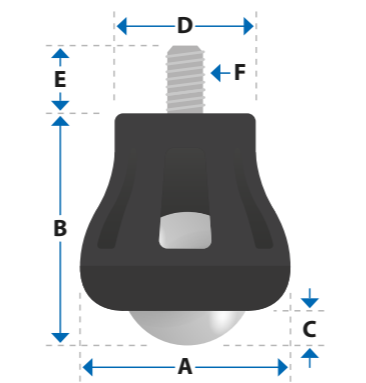

OC100 & OC100B



PART	OC100 & OC100B
MAX LOAD	80 kg
BALL Ø	104
A	143
B	151.5
C	29
D Ø	58
E	25
F	M12 x 1.75
G	46 (OC100)
G	34 (OC100B)

Metric dimensions subject to general tolerance of +/- 0.3mm

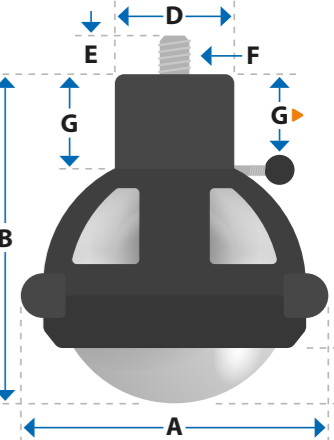

- Debris Exit
- Brake Option
- Fixing Options: N12, T12

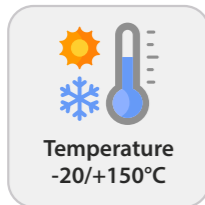

PART	MAX LOAD (kg)	A BALL Ø	B MIN - MAX	C	D	THREAD
OF 35-55	18	35	54 - 76	92	27.5	M14 x 1.5
OF 35-75	18	35	54 - 71	87	37.5	M14 x 1.5
OF 50-100	22	50	69 - 91	107	50	M14 x 1.5

Omnifloat castors allow smooth conveying & directional change with minimal damage to delicate surfaces. Specified throughout the glass handling industry for conveying glass through wet, corrosive, dusty & high temperature processes.

Omnifloats are typically supplied with a 50% mix of 'left hand' & 'right hand' swivel trail. We recommend fitting the castors in a regular, alternate pattern to minimise bias & provide a neutral conveying plane.

Replacement balls available as spares. Alternative materials can be retro-fitted for extended durability & service.

TO ORDER:

- 1 Select model OF35-55 / OF35-75 / OF50-100.
- 2 Specify Ball material: R = Rubber, P = Polyurethane & HT = High Temperature (i.e. OF35-75HT).
- 3 Stainless Steel Arm required? Add suffix SS (otherwise zinc plated steel arm).

Replacement balls available as spares. Alternative materials can be retro-fitted for extended durability & service.		REPLACEMENT BALL #	
SUFFIX	SPECIFY MATERIAL	35 mm	50 mm
R	Rubber Ball Better grip (Black). 70 Shore A -20°C to +80°C	S35R	S50R
P	Polyurethane Ball Wear resistant (Caramel). 92 Shore A -20°C to +80°C	S35P	S50P
HT	High Temperature Heat resistant (Red). 80 Shore A -20°C to +150°C	S35HT	S50HT
SS	Corrosion / Chemical attack Specify Stainless Steel Arm (AISI 304). Standard arm is zinc plated steel (AISI 1113).		

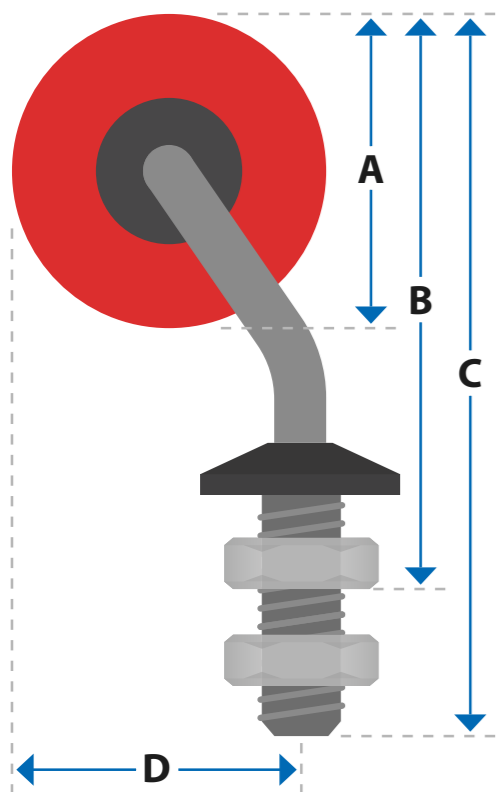

Remove



Snap Fitting

Omnitrack Flexible Conveyors - Versatile & mobile conveyor modules. Compact conveyors extend up to 3.6 times their retracted length & sturdy castors are then locked once positioned. All models are height adjustable & assembled with either Skatewheels for flat based items & tighter turns, or Conveyor Rollers for increased support of irregular/deformable items. Rollers & wheels are produced from low-inertia, high-impact PVC.

- 80 kg/metre load rating.
- Adjustable working height (650 - 1100mm).
- Maximum axle pitch 125mm (extended).
- 400 mm or 600 mm standard conveyor width.
- Other models & materials available.

FLEXIBLE CONVEYORS WITH SKATEWHEELS

- for flat-based items & for tighter turns.

400mm WIDTH	600mm WIDTH	EXTENDED LENGTH	RETRACTED LENGTH
S400/2000	S600/2000	2	0.63
S400/3500	S600/3500	3.5	1.02
S400/5000	S600/5000	5	1.41
S400/6500	S600/6500	6.5	1.8
S400/8000	S600/8000	8	2.19
S400/9500	S600/9500	9.5	2.58

Dimensions in metres

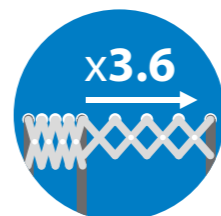
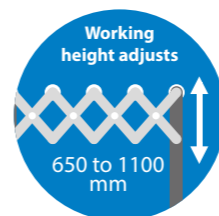
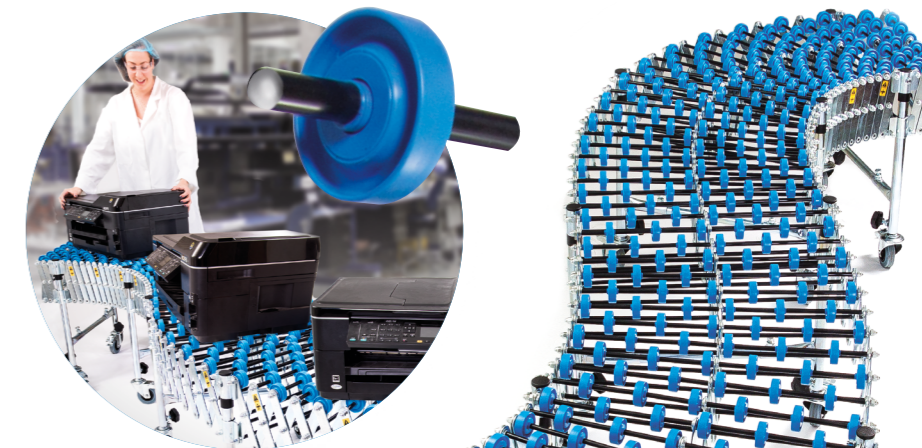

FLEXIBLE CONVEYORS WITH ROLLERS

- for increased support of irregular/deformable items.

400mm WIDTH	600mm WIDTH	EXTENDED LENGTH	RETRACTED LENGTH
R400/2000	R600/2000	2	0.94
R400/3500	R600/3500	3.5	1.56
R400/5000	R600/5000	5	2.18
R400/6500	R600/6500	6.5	2.8
R400/8000	R600/8000	8	3.42
R400/9500	R600/9500	9.5	4.04

Dimensions in metres

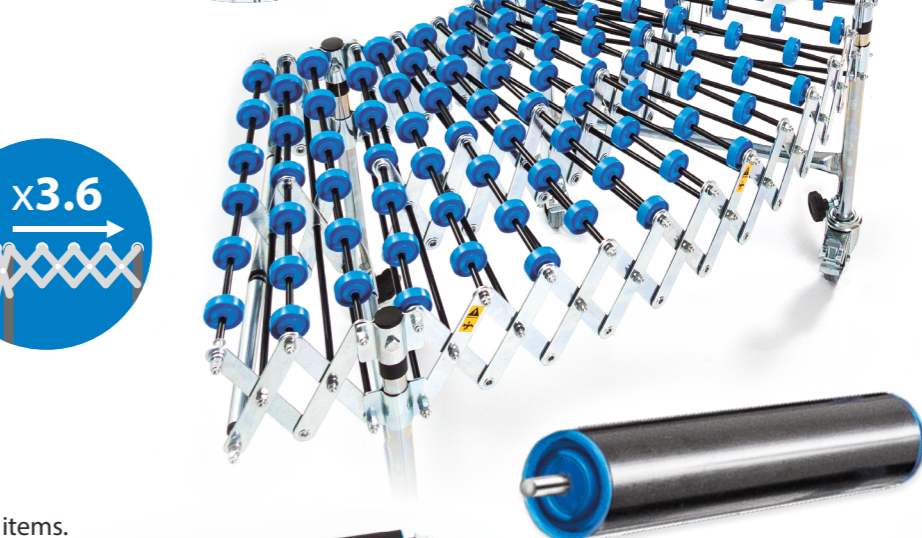

Optional CONNECTING HOOKS link multiple conveyors together (CH1).

PART	OPTIONAL PARTS
CH1	Connecting Hooks (1 Pair)
ES400	End Stop (400 mm width)
ES600	End Stop (600 mm width)

Optional END STOPS (ES400/ES600) or Ball Platforms & Tables (page 26).





- Delicate Handling** (Feather icon)
- Speed 1m/sec** (Speedometer icon)
- Temperature -20/+100°C** (Thermometer icon)
- Non-magnetic Construction** (Magnet icon)
- Irregular & Deformable Objects** (Irregular shape icon)
- Washdown Conditions / Dirt Debris** (Water spray icon)

Omniwheels feature peripheral rollers which provide 360 degree movement & support of irregular shaped items. Ideal for assembly & inspection lines, machine feed & packing areas. Driven & Automatic Sorting systems available - contact us.

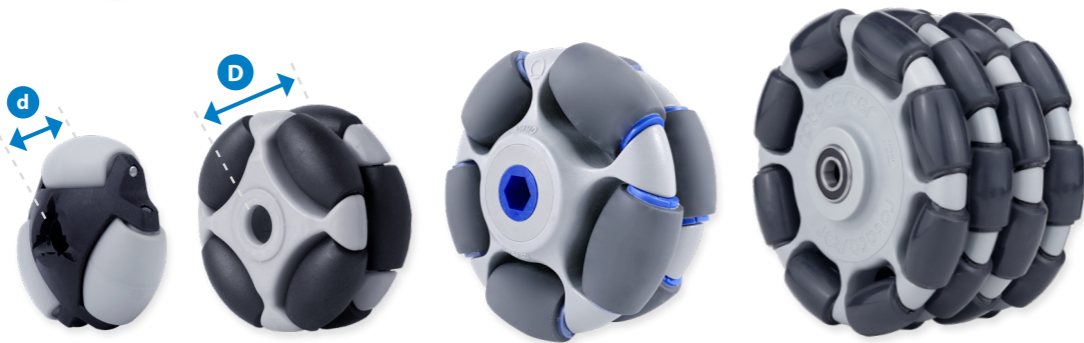
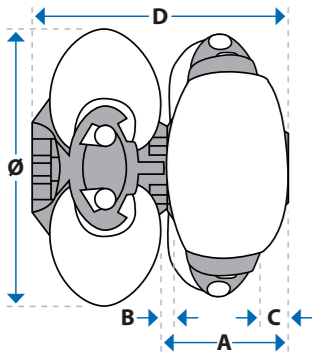

PART	A	B	C	D
OW48-1-(x)-(y)	21	3	3	40
OW80-1-(x)-(y)	34	4	4	65

- OW48-1-(x)-(y) / OW80-1-(x)-(y)
- OW35-2-(x)-(y) / OW50-2-(x)-(y)
- OW90-3-(x)-(y)
- OW125-4-(x)-(y) / OW180-4-(x)-(y)

DIAMETER & CONSTRUCTION	PART CONFIGURE VALUES: (X) & (Y)	(X) CONFIGURE HARDNESS SHORE A		(Y) CONFIGURE HUB CENTRE OPTIONS (MM)							
		HARD MATERIAL = HIGH LOAD (X) KG	SOFT MATERIAL = LOW LOAD (X) KG	(Y) = P PLAIN BUSH	(Y) = H HEX DRIVE	(Y) = B SEALED BEARING					
35	OW35-2-(x)-(y)	99	5	35	2	18.5	P1 P2 P3 P4	18.5	-	18.5	-
48	OW48-1-(x)-(y)	99	8	-	-	21.5	P4	22	H1	-	-
50	OW50-2-(x)-(y)	95	25	74	15	27.5	P2 P3 P6 P8 P9	27.5	H2 H3 H5 H6	27.5	B2 B3
80	OW80-1-(x)-(y)	99	25	-	-	65	P7	65	H4	-	-
90	OW90-2-(x)-(y)	95	85	75	75	43	P2 P3 P5 P6 P8 P9	43	H2 H3 H5 H6 H7	43	B2 B3 B4 B5 B6 B7
125	OW125-2-(x)-(y)	95	130	85	115	43	P2 P3 P6 P8 P9 P16	43	H2 H3 H5 H6 H7	43	B3 B5 B6 B7 B9
125	OW125-3-(x)-(y)	95	160	85	130	62		62		62	
125	OW125-4-(x)-(y)	95	260	85	250	86		86		86	
180	OW180-2-(x)-(y)	95	300	85	145	57		57		57	
180	OW180-3-(x)-(y)	95	200	85	225	85	P2 P3 P6 P8 P9	85	H2 H3 H5 H6 H7	85	B5 B6 B7 B9 B20
180	OW180-4-(x)-(y)	95	260	85	250	114		114		114	

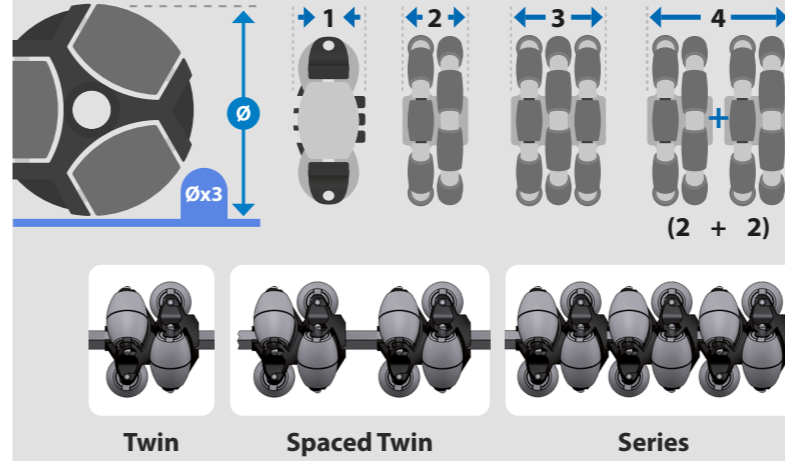

Diameter, Construction & Spacing

- Castor applications - ensure diameter is x3 minimum Ø of any step/obstacle in primary direction of travel.
- Synchronise rollers to achieve rapid directional change.
- Omniwheel OW48-1 & OW80-1 are singular but configure & synchronise by locking together in series.
- Other models pre-synchronised in x2, x3 & x4 construction for modular flexibility & support.

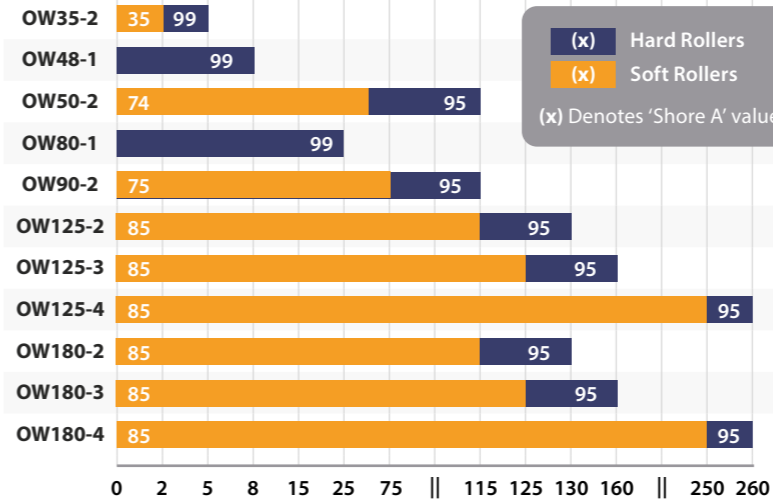

(x) Load & Roller materials

- Heavy loads require higher Shore A roller hardness; softer, cushioning materials compromise load capacity.
- OW48 & OW80 feature stainless steel axles, other models of non-magnetic, all-plastic construction except when specifying bearing centre hub option.

HARDNESS SHORE A	35	85	95	99
EXAMPLE ITEM				
	Pencil Eraser	Shoe Heel	Skateboard Wheel	Shopping Cart Wheel

PLAIN Ø	P1	P2	P3	P4	P5	P6	P7	P8	P9	P16
Internal Ø mm / inch	3/16"	6	8	8.2	10	12	12.2	1/2"	7/16"	16
HEX DRIVE	H1	H2	H3	H4	H5	H6	H7			
AF mm / inch	8.1	3/8"	7/16"	11.2	1/2"	14	19			
SEALED BEARING #	B1	B2	B3	B4	B5	B6	B7	B8	B9	B20
Internal Ø mm / inch	3/16"	6	8	3/8"	10	12	1/2"	5/8"	15	20

(y) Hub Centre & Inserts

- Plain bush – suffix P – for gravity conveyor applications.
- Hexagon drive - suffix H – for driven conveying.
- Sealed bearings – suffix B – for caster & trolley applications.



Accessories

- Castor brackets & fixing flanges.
- 'Live-storage' section channels & axles.
- Specify pre-cut or custom spacer tubes to reduce density for larger rigid items.

Driven systems
Contact us

Heavy Duty Tables & Platforms

We'll design & build your custom solution – just send us your application criteria:

UNIT SPACING

Shortest dimension

3.5

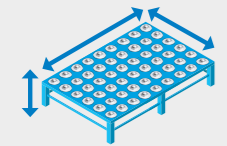

Table / Platform Dimensions

Sides & end stops?



Conveyed Item(s)

Maximum/minimum dimensions & weights.



Conveyed Item(s)

Material & finish, deformability & flatness.



Special Operations

Shock loads, speed, assembly procedures.



Operating Environment

Outdoors, refrigerated conditions, hygienic & washdown areas.

Ball Tables & Conveying Platform - 300kg Capacity

Configure your ideal 'off the shelf' conveying solution for loads of up to 300 kg. Aluminium frames shipped with detachable legs for easy transit & storage. Full assembly instructions included. Frame layouts F1-1, F1-2, F2-2 & F2-3 can be joined to increase the conveying plane.

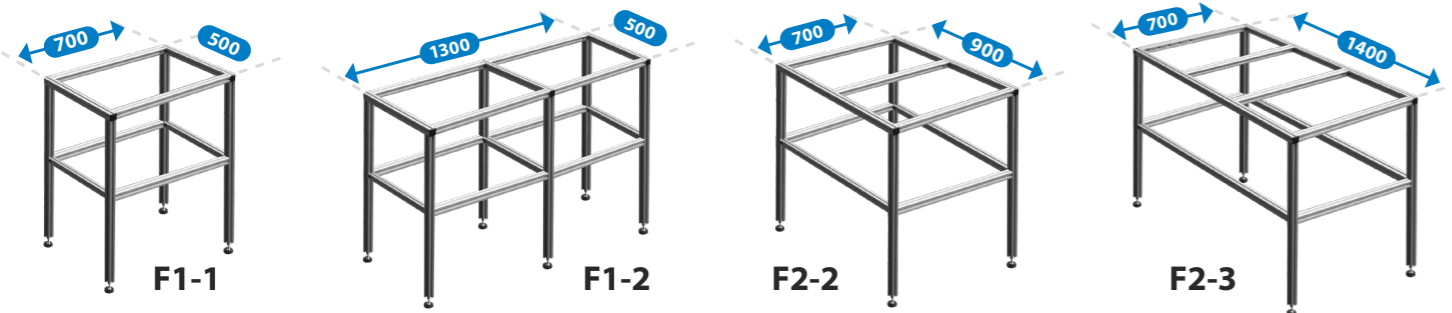

Ball transfers, Pneumatic & Omnicaster conveyor platforms arranged within standard 650 x 450 stainless-steel platforms. Omniwheels are assembled on 5 shafts & Pneumatic rails (x5) slot within standard aluminium frames (F1-1, F1-2 etc). Pneumatic 'live/dead' conveying planes require 3.4 bar compressed air supply (lubricated).

Standard pitch & sizes (shown below) available for immediate shipping from stock. Custom platforms with alternative units &/or pitch manufactured in-house for rapid despatch.

To order, quote frame type & conveying platform, for example 'OF35-75R'. If your application requires alternative pitch &/or conveying media, contact us.

	CONVEYING MEDIA	QTY.	LOAD / UNIT	PITCH	Σ SUPPORTED AREA	PROJECTION	FRAME
Ball Units	L22-K	35	120	90 x 90	350 x 560	10.1	F1-1
Pneumatic Ball	PB25	30	25	60 x 135	240 x 510	3.6-12.2	F1-2
Omniwheel	OW48-1	100	8	20 x 135	400 x 600	17.6	F1-2
Omnicaster	OC35	35	30	90 x 90	350 x 560	60	F2-2
Omnifloat	OF35-75R	35	18	90 x 90	350 x 560	54-76	F2-3

Standard (adjustable) legs 790 – 850 mm

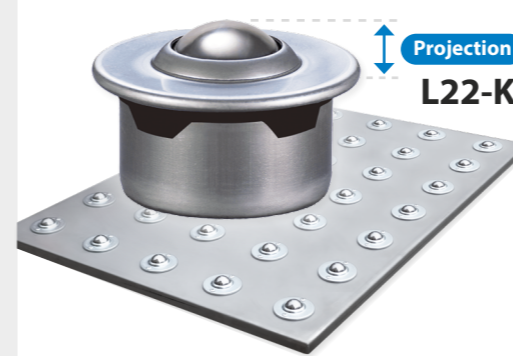

Projection L22-K



Projection PB25



Projection OW48-1



Projection OC35

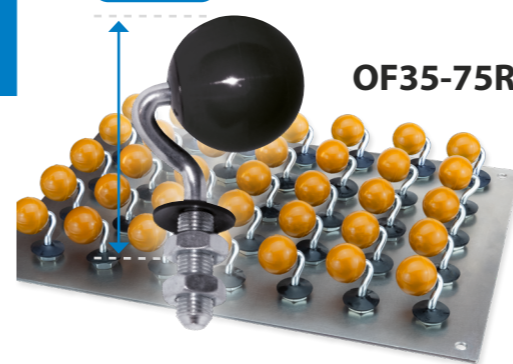

Projection OF35-75R

Ball Transfer Units



Heavy & shock loads



Low friction



Instant direction change



High & low temperatures



Pneumatic



Active / static conveying plane



Low friction



Instant direction change



Uneven Loads



Omniwheel



Driven conveyor systems



Outdoor, wet & contaminated conditions



Irregular & deformable objects



Washdown areas



Omnicaster



Delicate Contact



Contaminated conditions



Brake Option



Rapid drain & debris channels



Omnifloat



Glass & delicate sheet handling



Outdoor, wet & contaminated conditions



High temperature use



Service kits available



Omnitrack Ball Transfer Rails - Construct a bespoke & flexible conveying plane by configuring ball transfer rails to your application. Ideal in live storage applications, the rails can be installed individually using optional fixing brackets or bolted together either with or without optional spacer tubes to form a ball transfer platform.

400 mm & 600 mm standard lengths for rapid integration within existing conveyor roller installations. Ball transfer units available with alternative material upgrade options.

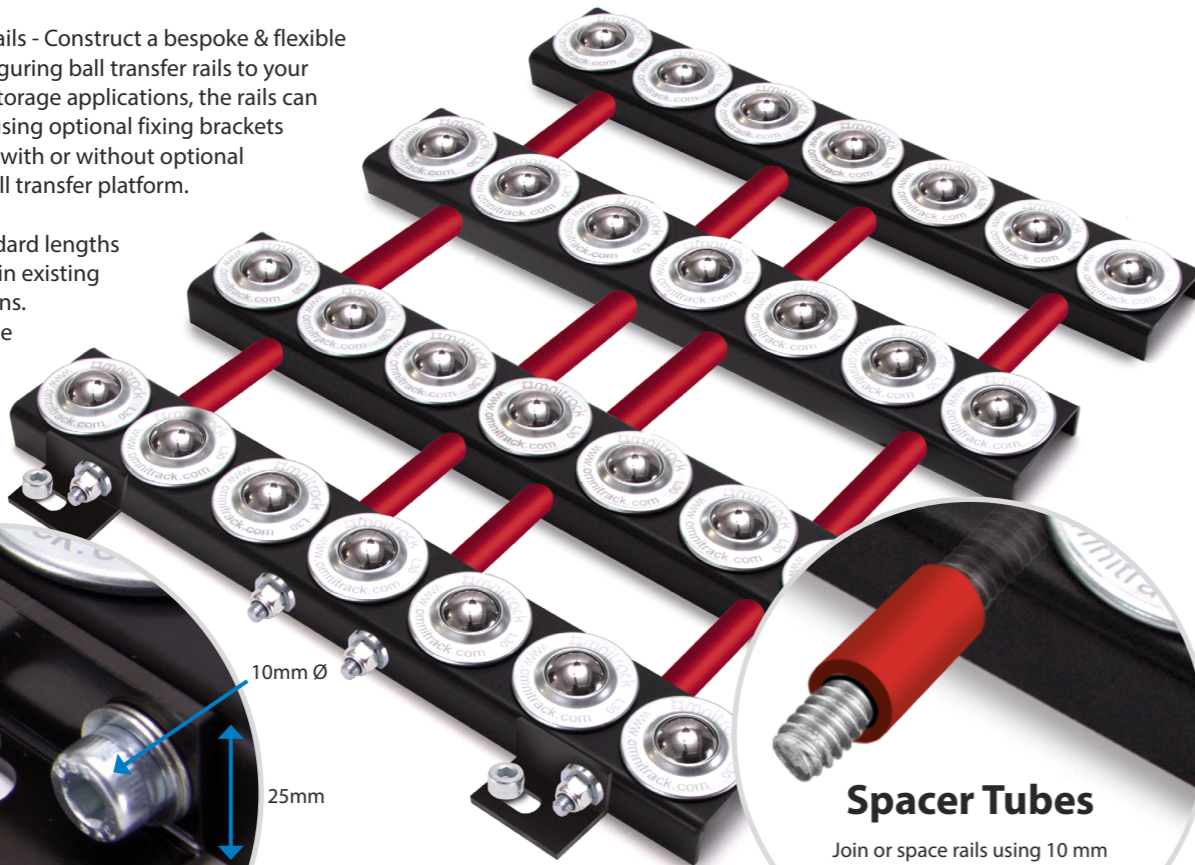

Fixing Brackets

Optional - Part # RB-1 (each)

Spacer Tubes

Join or space rails using 10 mm (3/8") Ø through holes. Spacer tubes cut to order.

BALL Ø	RAIL LENGTH # OF BALL UNITS @ SPACING				MAX LOAD (kg)									A RAIL WIDTH	B FITTED HEIGHT	C RAIL HEIGHT			
	400 MM LENGTH		600 MM LENGTH		Standard			A			D						SS		
	Unit	400	600	Unit	400	600	Unit	400	600	Unit	400	600	Unit				400	600	
15	R15-400	10 @ 40	R15-600	15 @ 40	60	600	900	60	600	900	10	100	150	40	400	600	40	34.5	25
22	R22-400	8 @ 50	R22-600	12 @ 50	160	1280	1920	160	1280	1920	20	160	240	90	720	1080	50	34.8	25
30	R30-400	7 @ 58	R30-600	10 @ 60	280	1960	2800	280	1960	2800	25	175	250	200	1400	2000	60	38.8	25

R15



R22



R30

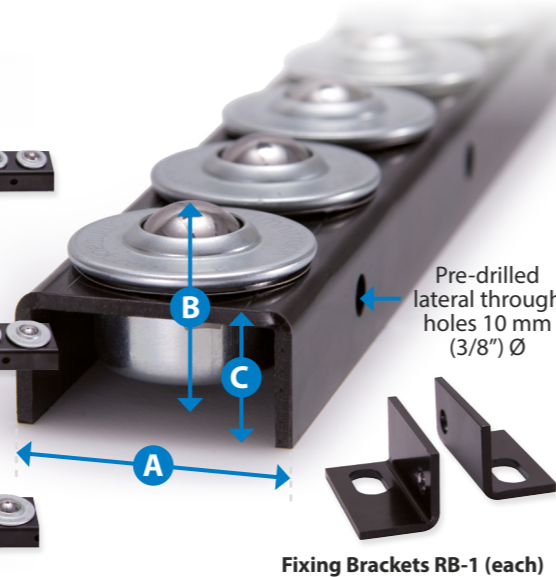

Fixing Brackets RB-1 (each)

Ball Skate BB30/4

- 1000 KG 1000 kg load per skate
- (!) Parking brake standard
- Lightweight & durable
- Stainless steel balls

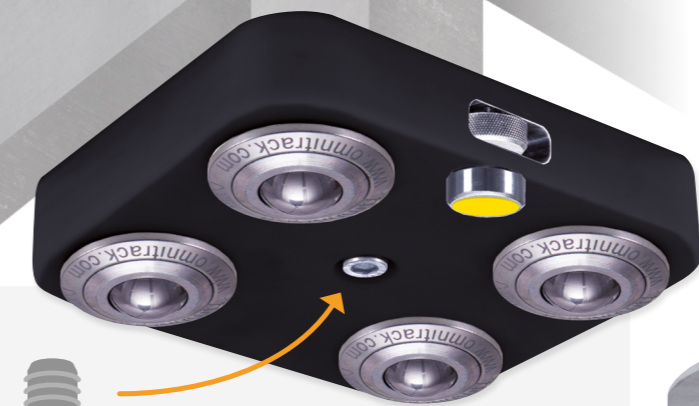

12.7mm Ø through counterbore facilitates:
• Socket head capscrew for permanent attachment.
• BL2 Load Plate (optional).



Optional - BL2 Load Plate

Accepts most standard legs

Circular Leg Recess
20mm Ø - 80mm Ø

Square Leg Recess
20mm² - 100mm²

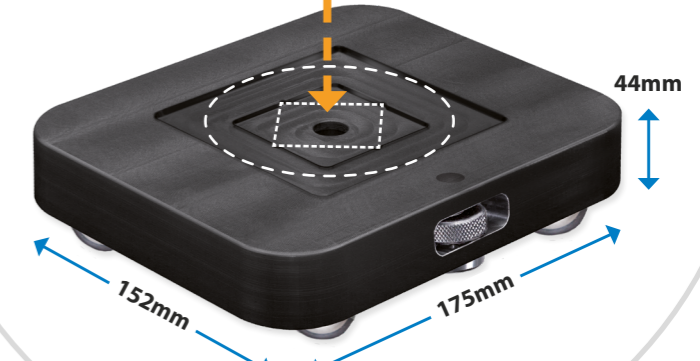

Ground Clearance 13.8 mm
Ball Projection 5.5 mm

Pry Bar
Part # BP2

Use to lift or lever items & fit/remove ball skates. Heavy duty 2 - Piece design for ease of transport.



Shelving Tie Brackets
Part # BS2

Ball skates are ideal to move laden connected shelving aisles. Use universal tie brackets to secure upper areas of connected gondola shelving.

Load Plate - Part # BL2

Ideal where flat or wide surfaces require increased support. Easy push fit & removal utilising central hole in skate.

Evaluate these aspects when choosing your solution:

Orientation

Which position does your application require the units to be mounted or function? Load ball up, down or other? Heavy duty range units operate at maximum load in all orientations.

Track & Contact

What is the condition, hardness & surface finish of the material the units will be conveying or bearing against? Uneven, deformable & delicate surfaces need special consideration.

Load & Shock

Dynamic & static load ratings are identical. Where loads are unevenly distributed or high impact/shock conditions exist, spring loaded units are ideal.

Speed

Maximum conveying speeds are limited; frequency & duration may also require consideration. Dynamic & static speed ratings are identical.

Friction & Precision

Lowest coefficient of friction & highest levels of precision movement are provided by the heavy duty ball units (pages 4 - 9). Some applications will allow a design concession to be made.

Stability

Consider the stability of the conveyed item. Ensure sufficient points of contact (pitch) to consistently support the mass. Provision for control & braking of the mass should not be overlooked.

Environment

Consider material upgrade options to better resist adverse environmental operating conditions. Dirty or dusty conditions? Wet & contaminated areas? Chemical attack / contamination? Magnetic permeability & radioactive fields?

Lubrication & Service

Omnitrack products are lubricated for life. To further extend service life, heavy duty ball transfers & Omnifloat ranges offer additional user-service kits. Consult page 7 for heavy duty ball units & page 20 for Omnifloat glass handling casters.

Temperature

Ambient temperature & maximum/minimum temperature ranges must be evaluated. Stainless steel components resist higher & lower temperatures better than standard materials (page 29).

	KG MAX LOAD	μ FRICTION % OF LOAD	SPEED m/sec	SHOCK LOADS	ARDUOUS CONDITIONS	ORIENTATION	INSTANT CHANGE
Heavy Duty	8000	0.5	2	✓✓✓✓✓✓ 94-97 Series	✓✓✓✓✓✓ 90-93 & 98 Series	✓✓✓✓ Z & SS options	✓✓✓
Pneumatic	25 & 35	3	1.5				
Medium Duty	3500	2	1.5	✓✓✓✓✓ MM - MN Series	✓✓✓✓ MX Series	✓✓✓✓ MW, MV30 & SS option	✓✓✓
Light Duty	7-600	3	1	✓✓✓ LM series	✓✓	SS options	✓✓✓
Omnicafter	30 & 60	3	1	✓	✓✓✓		✓✓
Omnifloat	18 & 22	6	1	✓✓	✓✓✓✓		✓
Omniwheel	8 & 25	5	1	✓	✓✓✓✓		✓
Flexible Conveyors	80/m	4	2	✓✓	✓✓✓✓		✓✓
Rails & Tables	300+	3	1	✓	✓✓		✓
Skates	1000	3	1.5	✓✓	✓✓✓		✓

Load & Stability

Ensure sufficient load capacity:

Load
3

3000 KG

1000 kg 1000 kg
= 3 x 1000Kg

Unit Spacing:
Shortest dimension
3.5

Specify spring loaded units where shock loads & uneven track conditions exist.

Operating Temperature

Compensate for temperature & operating environment by reducing stated load capacity

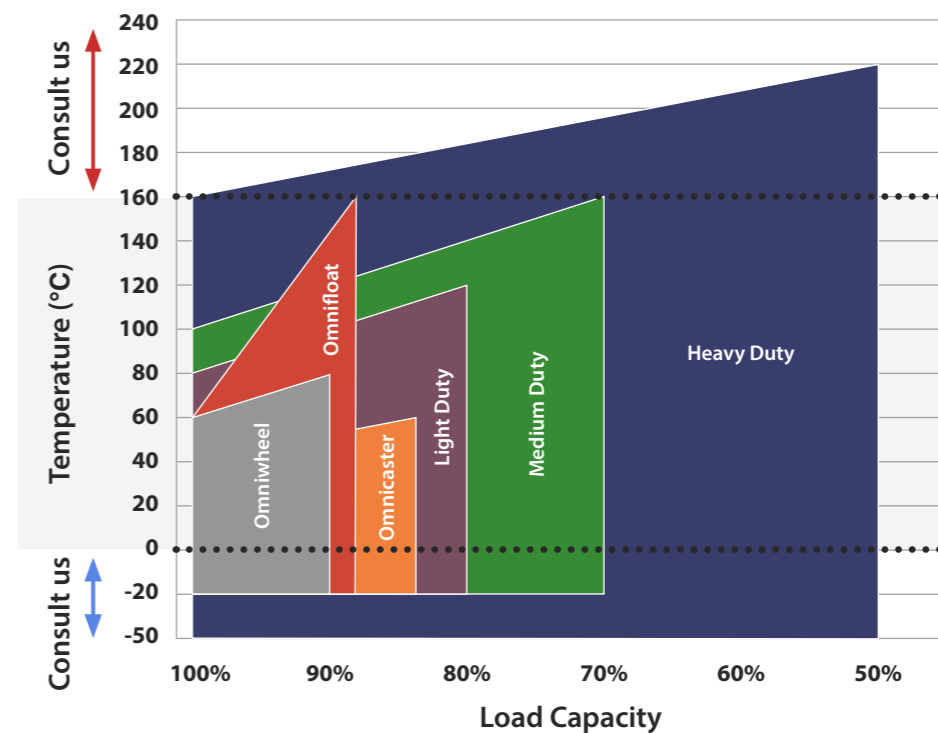

Free technical advice



Bespoke design



In-house manufacturing



No minimum order



UK design & made



Immediate shipping

Making History Since 1909



2021

New 2021
Omniwheel Range



2020

New compact
8000 series



2017

Heavy duty 8000
kg Ball Unit. New
technology & materials

2011

Bloodhound' 1000mph
Land Speed Record
(Product Sponsor)



2009

CERN 'Hadron' collider
particle research
project supplier

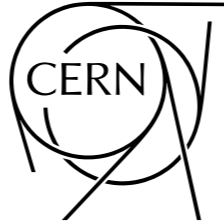

2014

New Omnicaster
Range Launched



1970

Blue Steel nuclear
warhead handling
equipment - design &
production



1990

Euro Fighter
production
project supplier



1930

Belt 'Linisher'
designed & launched

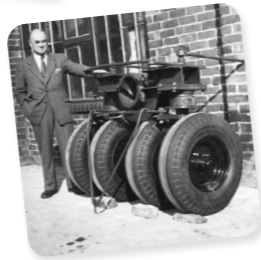
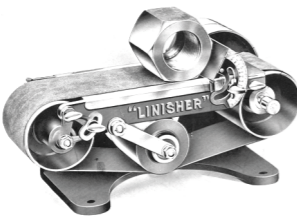

1962

De Havilland
Aircraft landing
gear - design
& manufacture
contract

1958

1958 Patented
Omni-track Ball
Transfer Units
launched

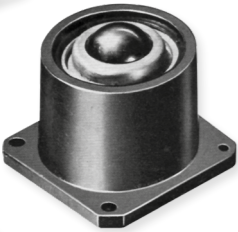

1928

Gravity conveyor
rollers, Skatewheels &
live racking systems
launched



1918

Autogliders' scooter
range - Mass produced
& exported



1909

Inception as manufacturer of Lathes, heavy
duty Castors & Cabinet Drawer Slides

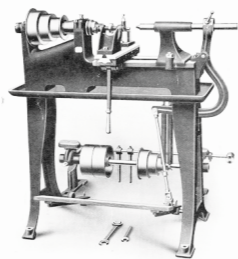

1896

Rodborough Court,
our HQ in Stroud - UK
was constructed

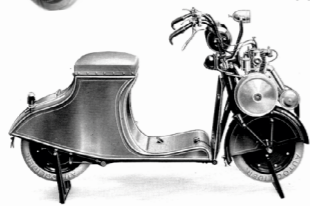

In-house World-Class Manufacturing



100% Product Quality Testing



2 Year Warranty

Register your free 2-year warranty online now
- Scan the QR code below with your mobile
phone. Our quality is your guarantee.

2
★
YEAR
WARRANTY

omnitrack
2 YEAR
WARRANTY

Global sales & design
support team





omnitrack®

omnidirectional movement

Versione 40.1 / UK - www.giovanatows.com

United Kingdom
01453 873345

Canada
1 647 258 4756

France
01 8721 0069

USA
1 914 600 5422

Deutschland
0800 18 33 297

México
01800 681 9310

Italia
0362 1321595

Brasil
11 4349 6211

España
91 198 4543

Australia
1800 824 493

Portugal
308 804 777

New Zealand
03 669 4787

România
0364 228 049

South Africa
010 595 1272

POСсия
8800 100 9654

Türkiye
0216 900 2808

Netherland
020 703 8306

India
000 800 100 4384

Colombia
1 3819434

中国 China
北 10 800 713 1349
南 10 800 130 1308

DAILY WORLDWIDE SHIPPING



Rodborough Court - Stroud - GL5 3LR - England

info@omnitrack.com

+44 1453 873345

www.omnitrack.com