



The Huck®
Product Range



How It Works

Huck Lockbolts

Clamp Force or Pre-Load: In the initial stages of the installation process, the tool engages and pulls on the pintail. The joint is pulled together before the conical shaped cavity of the nose assembly is forced down the collar. This progressively locks (swages) it into the grooves of the harder pin. The pin and swaged collar combine to form the installed fastener.

The squeezing action reduces the diameter of the collar, increasing its length. This in turn stretches the pin, generating a clamp force over the joint.

Shear strength of Lockbolts vary according to the material strength and minimal diameter of the fastener. By increasing the diameter or the grade of material, the shear strength of the fastener can be increased.

The tensile strength of Lockbolts is dependent on the shear resistance of the collar material and the number of grooves it fills.

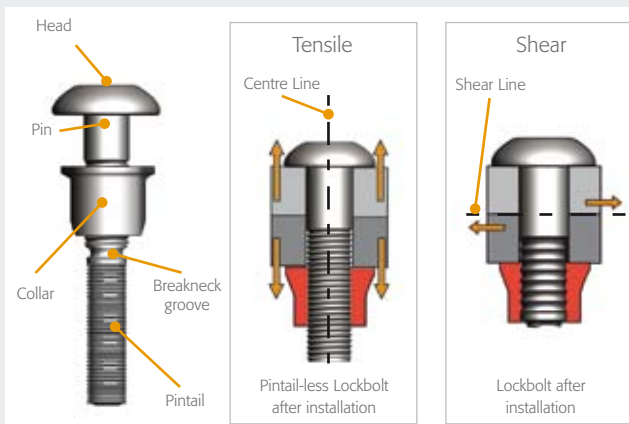

Huck Structural Blind Fasteners

The **shear strength of structural blind fasteners** is generated by the combined resistance against failure of the pin and sleeve. This takes place along the joint's shear line between fastened plates.

The **tensile strength of structural blind fasteners** differs to that of Lockbolts, as they form a blind side positive lock either by bulbing or expanding of the sleeve. The sleeve, assisted by the permanently secured pin, therefore resists failure along its centre line.

1. Bulbing – the sleeve of the fastener is compressed, causing it to fold outwards to form a bulb. This forms itself tightly against the joint material. Once the pin is permanently locked into place the pintail will break off, completing the installation.

2. Expanding – pulling on the pintail causes the head of the pin to draw into the sleeve. This expansion causes a foot print to form against the joint material.

Note: The pre-load of blind rivets is generally not published, as it varies widely depending on the application

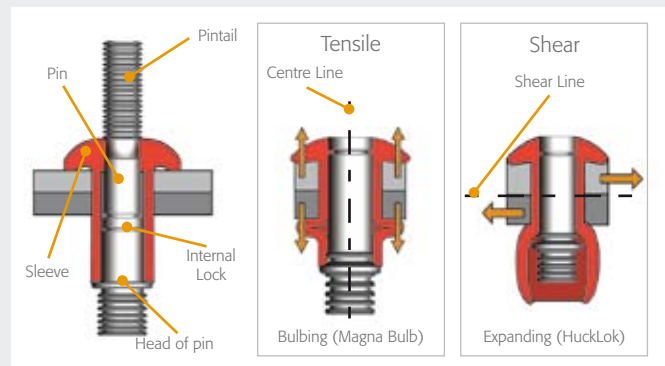

Installation Sequence

Lockbolt installation sequence

- 1 • Pin placed into prepared hole
• Collar placed over pin
- 2 • Tool is placed over the fastener pintail and activated
• Pin head pulled against material
• Anvil pushes collar against joint
• Initial clamp generated
- 3 • Tool swages collar, increasing clamp
- 4 • Pintail breaks, installation complete

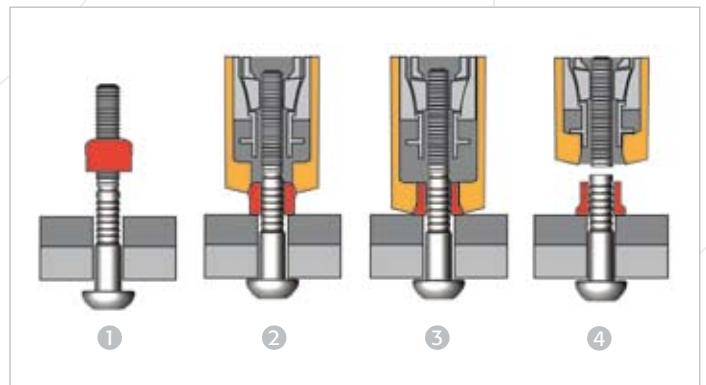

Blind Fastener installation sequence

- 1 • Pin placed into prepared hole
• Tool is placed over the fastener pintail
- 2 • Tool activated
• Deforming of blind side begins
- 3 • Joint tightened
• Internal locking mechanism formed
- 4 • Pintail breaks, installation complete

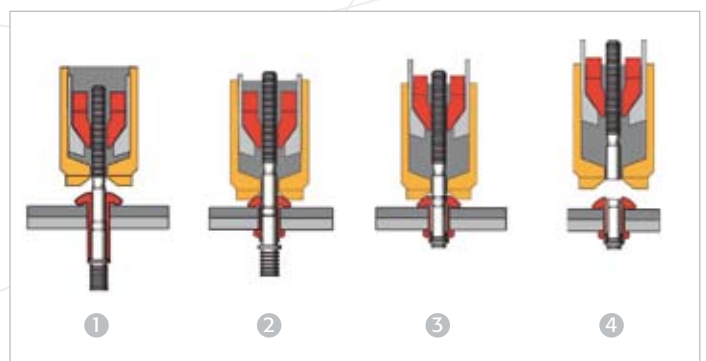

Huck LockBolts

Key Benefits:

- Permanent, mechanically locked fastener
 - Installation process automatically provides fastener values
 - No torque or re-torque required
- Unlike conventional nuts and bolts, they will not work loose, even during extreme vibration

- Rapid installation with Quick and easy visual inspection
- Excellent gap closure capability
- Can be installed onto angled surfaces (5° maximum)
- Tamperproof

C6L® - The Original Huck Design

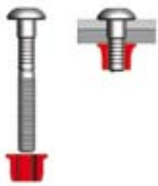

5.8 grade small diameter Lockbolt

Made to British Standard B7805: Part 1: 1997: A mark of quality, safety and performance

Wide flange collar available: Enables installation into non metallic materials

Pin head style: Brazier, truss, countersunk, specific headstyle for palisade fencing

Collar style: Standard, flanged, wide flanged and low profile

Materials: Steel, stainless steel, aluminium

Diameters (mm)

4.8 6.4 7.9 9.5



C50L®



8.8 grade large diameter Lockbolt

Made to British Standard B7805: Part 2: 1997: A mark of quality, safety and performance

High tensile friction grip fastener

Pin head style: Round, truss, countersunk, thread head

Collar style: Standard, flanged, low profile

Materials: Steel, stainless steel, aluminium

Thread head variety available for rail track applications

Diameters (mm)

12.7 15.9 19.1 22.2
25.4 28.6 31.8 34.9



C120L®

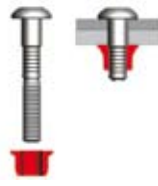

8.8 grade small diameter Lockbolt

High tensile strength version of C6L

Pin head style: Brazier, truss, countersunk

Collar style: Standard, flanged

Materials: Steel

Diameters (mm)

4.8 6.4 7.9 9.5



Huck-Fit®



10.9 grade large diameter Lockbolt

High tensile friction grip fastener

Unique helical lock groove: Can be used as a Fit up bolt#

Unique helical lock groove: Holds pins and collar in place prior to installation#

Can be removed with conventional tools

Pin head style: Flanged hexagonal

Collar style: Flanged hexagonal

Materials: Steel

Diameters (mm)

12 14 16 20
24 27



Magna-Grip®



Huge grip range: Accommodates wide variations in joint thickness - 14.3/23.9mm *

One pin and one collar cover a wide variety of applications: Reducing the risk of incorrect fastener installation

Wide grip range minimises fastener inventory

Flush pinbreak: No catching on clothes, skin or goods

Pin head style: Button, truss, countersunk, rivet, broad truss

Collar style: Standard flange, medium flange, wide flange

Materials: Steel, aluminium

Diameters (mm)

4.8 6.4 7.9 9.5



Huck-Spin® / BobTail®

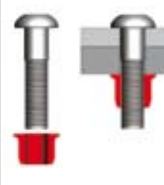

High tensile friction grip fastener

No pin-tail: Reduced wastage, low installation noise, no pinbreak: increased corrosion resistance

Semi-automatic tooling installation: Minimises installation time

Unique helical lock groove: Holds pins and collar in place prior to installation

Pin head style: Flanged hexagonal, flanged round

Collar style: Flanged hexagonal, flanged round

Materials: Steel

Illustration shows Huck-Spin installation

Diameters (mm)

6.4 7.9 9.5 12
14 16 20

Hucktainer® - Designed specifically for joining composite board in trailer applications.



Will not crush or damage the composite board
Integral seal around pin head prevents moisture ingress

Low profile on both sides when installed:

No catching on clothes, skin or goods. Not as grip sensitive as some competitor products

Diameter (mm)

9.5

Pin head style: Standard low profile, encapsulated in plastic

Sleeve style: Wide bearing, medium bearing, clearance

Materials: Steel



* Based on 6.4mm diameter. Two different grip lengths available. # Special tab collar is need to perform this function

Huck Structural Blind Fasteners

Key Benefits:

- Internal locking mechanism retains the pin
 - Structural fastener after installation
 - Higher strength than a standard open end blind fastener
- Ideal for use where access is limited on one side of the application
- Preassembled fastener - Insert one part in the hole and install
- A variety of installation tooling options available

Magna-Lok®

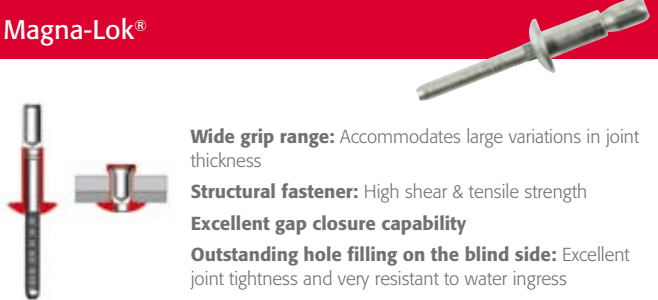

Wide grip range: Accommodates large variations in joint thickness

Structural fastener: High shear & tensile strength

Excellent gap closure capability

Outstanding hole filling on the blind side: Excellent joint tightness and very resistant to water ingress

Flush pinbreak: No catching on clothes, skin or goods. Quick and easy visual inspection

Internal pin locking mechanism: Secure within the rivet body and protected from corrosion

Headstyles: Protruding, truss, countersunk

Materials: Steel, stainless steel, aluminium

Diameters (mm)
4.8 6.4 9.5

Magna-Bulb®

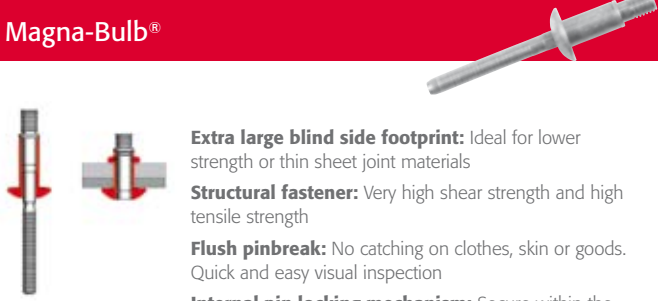

Extra large blind side footprint: Ideal for lower strength or thin sheet joint materials

Structural fastener: Very high shear strength and high tensile strength

Flush pinbreak: No catching on clothes, skin or goods. Quick and easy visual inspection

Internal pin locking mechanism: Secure within the rivet body and protected from corrosion

Headstyles: Protruding

Materials: Steel

Diameters (mm)
4.8 6.4 7.9

HuckLok™



Combines the wide grip range of the Magna-Lok and the high shear strength of the Magna-Bulb

Wide grip range: Accommodates large variations in joint thickness

Structural fastener: High shear & tensile strength

Large blind side footprint: Ideal for lower strength or thin sheet joint materials

Flush pinbreak: No catching on clothes, skin or goods. Quick and easy visual inspection

Internal pin locking mechanism: Secure within the rivet body and protected from corrosion, plus additional blind side pin locking for increased fatigue life

Headstyles: Protruding

Materials: Steel

Diameters (mm)
4.8 6.4

Auto-Bulb™

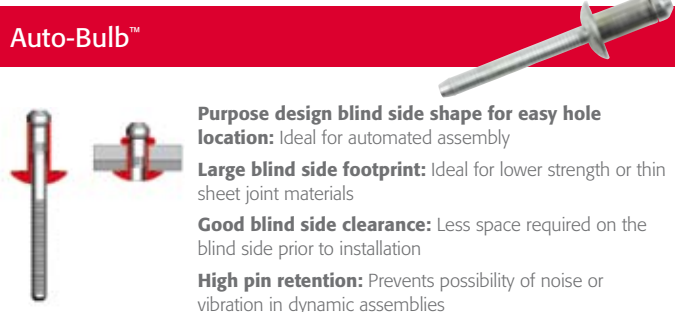

Purpose design blind side shape for easy hole location: Ideal for automated assembly

Large blind side footprint: Ideal for lower strength or thin sheet joint materials

Good blind side clearance: Less space required on the blind side prior to installation

High pin retention: Prevents possibility of noise or vibration in dynamic assemblies

Recessed pinbreak: No catching on clothes, skin or goods

Structural fastener: High shear & tensile strength

Headstyles: Protruding

Materials: Steel

Diameter (mm)
6.4

BOM®



Very high strength/diameter ratio: Can be used in demanding structural applications as an alternative to threaded fasteners or welding

Very high joint tightness when compared to conventional blind fasteners

Very resistant to tampering, extremely hard to remove

Excellent gap closure capability

Large blind side footprint: Ideal for lower strength or thin sheet joint materials

Headstyles: Protruding

Materials: Steel

Diameters (mm)
4.8 6.4 7.9 9.5
12.7 15.9 19.1

FloorTight® - The flooring specialist fastener

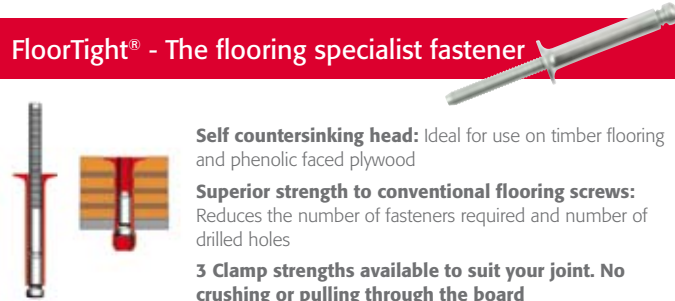

Self countersinking head: Ideal for use on timber flooring and phenolic faced plywood

Superior strength to conventional flooring screws: Reduces the number of fasteners required and number of drilled holes

3 Clamp strengths available to suit your joint. No crushing or pulling through the board

Recessed pinbreak: No catching on clothes, skin or goods

Wide grip range: Accommodates a large variation in joint thicknesses

Headstyles: Standard flange and wide flange

Materials: Steel

Diameter (mm)
7.9

Magna-Tite™ - The roofing specialist fastener



Polymer watertight seal: Ideal for roofing or similar applications

Extra large blind side footprint: Ideal for lower strength or thin sheet joint materials

Low clamp load: Perfect for use in thin sheet material, composites and plastics

Wide grip range: Accommodates a large variation in joint thicknesses

Flush pinbreak: No catching on clothes, skin or goods. Quick and easy visual inspection

Headstyles: Protruding, Low Profile, Shavable, 100° Oval

Materials: Aluminium

Diameters (mm)
4.8 6.4

4.8 to 9.5mm Diameter Lockbolts	Based on Diameter: 6.4mm Material: Steel			Material			Diameter (mm)									
	Material Grade	Shear Strength	Tensile Strength	Clamp Strength	Steel	Stainless Steel	Aluminium	4.8	6.4	7.9	9.5					
C6L	5.8				•	•	•	•	•	•	•					
C120L	8.8				•			•	•	•	•					
Magna-Grip					•		•	•	•	•	•	•				
Huck-Spin (Small Diameter)	5.8/8.8/10.9				•				•	•	•				•	•

Key for 4.8 to 9.5mm Diameter

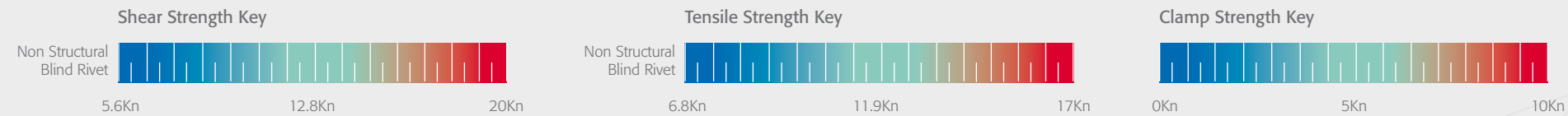

12 to 28.6mm Diameter Lockbolts	Based on Diameter: 16mm Material: Steel			Material			Diameter (mm)													
	Material Grade	Shear Strength	Tensile Strength	Clamp Strength	Steel	Stainless Steel	Aluminium	12/12.7	14	15.9/16	19.1	20	22.2	25.4	28.6					
C50L	8.8				•	•	•	•		•	•		•	•	•	•				
Huck-Fit	10.9				•			•	•	•		•				•	•	•		
Huck-Spin (Large Diameter)	10.9				•			•	•	•		•				•	•			•

Key for 12 to 28.6mm Diameter

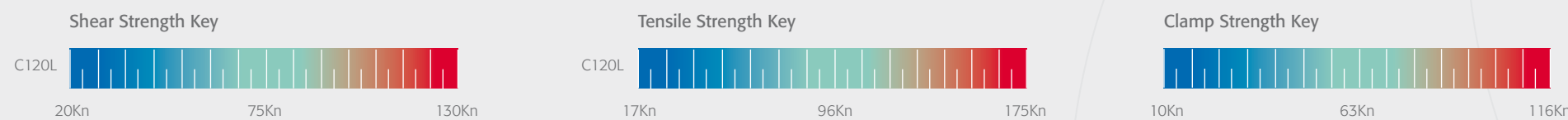

Structural Blind Fasteners	Based on Diameter: 6.4mm Material: Steel		Material			Diameter (mm)																	
	Shear Strength	Tensile Strength	Steel	Stainless Steel	Aluminium	4.8	6.4	7.9	9.5	12.7	22.2	15.9	19.1										
Magna-Lok			•	•	•	•	•		•					•	•	•	•						
HuckLok			•			•	•							•	• Double		•	•					
Magna-Bulb			•			•	•	•								•	•						
Auto-Bulb			•			•	•									•	•						•
BOM			•			•	•	•	•	•	•	•	•			•	•						
FloorTight	*	*	•											•						•			
Magna-Tite	**	**			•	•	•							•			•	•				•	

* only available in 7.9mm diameter. ** only available in aluminium.

Key for 6.4mm Diameter

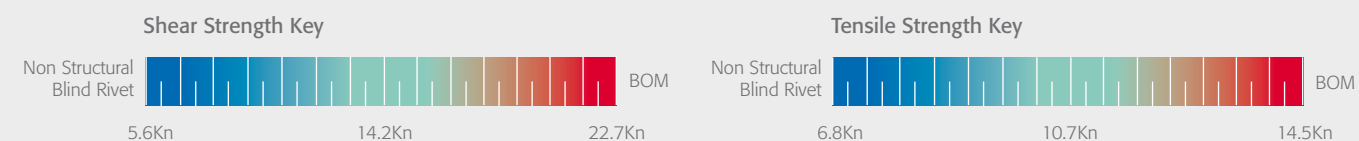

Icon Key

- Excellent Gap Closure
- Flush Pinbreak
- Pintail-less
- Includes Watertight Polymer
- Large Blindside Footprint
- Hole Seeking Tip
- Wide Grip Range
- Can be removed with a conventional tool
- Fit Function
- Internal Pin Lock
- Flooring Fastener

Huck Tooling Systems

Many different types of Huck installation tooling systems are available. Some of the most popular tools are shown below, but this is just a small part of our range. Discuss your requirements with our **dedicated Systems Engineering Team** to find the optimum solution to suit your need.

The basic tooling requirements to install Huck fasteners:

Installation Tool – Either pneumatic or hydraulic

Nose Assembly – To match with the fastener and tool

Powerig* – To supply power to hydraulic tools

Additional Hose Set – Sometimes required to connect hydraulic tools to the Powerig

2628



Hydraulic installation tool. Installs 14, 15.9, 16 & 19.1 mm large diameter Lockbolts and 15.9 & 19.1 mm BOM structural blind rivets.

202V



Pneudraulic installation tool with vacuum pintail collection bottle. Installs 4.8 & 6.4mm structural blind rivets.

2025LB



Pneudraulic compact powerful installation tool with pintail bottle. Installs 4.8 & 6.4 mm small diameter Lockbolts and structural blind rivets.

HK432 Series



3 phase electric, portable design. The Powerig can be used with all hydraulic installation tools.

HK432-2 Shown cannot install Huck-Spin or BobTail

2503



Hydraulic installation with extra long stroke. Ideal for installing 9.5mm Magna-Lok and 7.9 mm Floortight.

Will also install 7.9 and 9.5mm Lockbolts & Structural blind rivets.

HSSFT-M16UK



Hydraulic installation tool, compact swage forward design. Installs 14 & 16 mm Huck-Spin Lockbolts.

2480L



Hydraulic compact installation tool; high speed & high durability. Ideal for high volume production to install 4.8 & 6.4 mm small diameter Lockbolts and structural blind rivets.

The Unshakeable World of Huck Fastening Systems

For more than 60 years, the business Lou Huck founded and the fasteners he designed are still solving the problem of coping with extreme stress and vibration, providing strength and facilitating lighter, stronger, more durable structures.

Today the product range based on his original drawing of a Lockbolt now known as the HuckBolt® has evolved to include small and large diameter fasteners, medium and heavy duty blind fasteners and associated installation tooling.

In 2000 Alcoa, the world's leading producer of primary aluminium, fabricated aluminium and alumina became Huck's parent company. In 2002 they acquired Fairchild Fastening Systems and joined the two fastening institutions together to create Alcoa Fastening Systems (AFS), with Huck fasteners as a branded product.

With production resources across the globe, AFS provide engineered, high-quality, high-performance fastening systems for a variety of industrial applications.

Solution Needed, Solution Provided

Make our engineers part of your team at the concept stage. Their unrivalled knowledge of advanced fastener function can make the impossible possible. A standard fastener in our range may provide your answer. If not, we can produce a cost-effective tailor-made solution.

The Huck Fastening System – Key Benefits:

- Will not loosen even under extreme vibration
- Maintenance free joints – no need to torque or re-torque
- Lower lifetime total cost of joint - high shear and tensile strengths for increased fatigue life of the joint
- High speed, easy to install systems can reduce production time by 75%
- Improves health and safety - replace welded joints
- Tamperproof – once installed cannot be removed without specialist tooling

Contact

Alcoa Fastening Systems
Telford Operations,
Unit C, Stafford Park 7
Telford
TF3 3BQ
England
Tel : +44 (0) 1952 290011
Fax : +44 (0) 1952 204670
Email : info@huckfasteners.net
Web : www.afshuck.net

Alcoa Fastening Systems
Kelkheim Operations,
Industriestr. 6
65779 Kelkheim
Germany
Tel : +49 (0) 6195-805-0
Fax : +49 (0) 6195-2001

Alcoa Fastening Systems
St Cosme Operations,
9 rue de Cressonnieres
72110 Saint Cosme en Varais
France
Tel : +33 (0) 2.43.31.41.00
Fax : +33 (0) 2.43.31.41.41

Disclaimer:

The information contained in this publication is only for general guidance with regard to properties of the products shown and/or the means for selecting such products, and is not intended to create any warranty, express, implied, or statutory; all warranties are contained only in AFS's written quotations, acknowledgments, and/or purchase orders. It is recommended that the user secure specific, up-to-date data and information regarding each application and/or use of such products.

AFS HA16 AUG 2008

©2008 Alcoa Fastening Systems Ltd. All rights reserved.

www.afshuck.net | info@huckfasteners.net



TS 504575-000
FM 80437



EMS 60542

**Alcoa
Fastening
Systems**

