

DURA Flexball® -Remote Controls

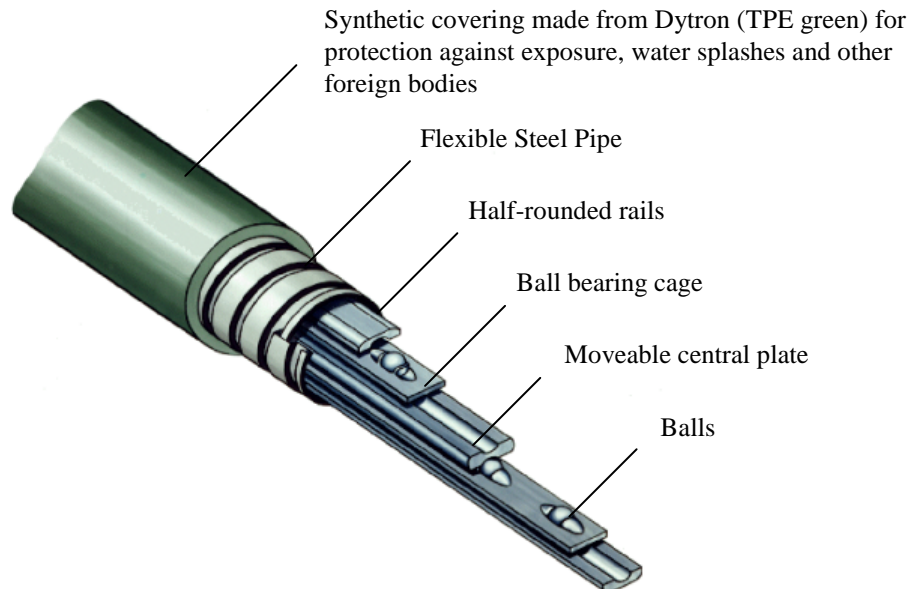

DURA FLEXBALL® the mechanical, ball bearing, flexible remote control transfers linear lifting movements of up to 200 mm. Only the ball-bearing principle used enables loads of 6000 N pressure and 15000 N traction so easily and smoothly.

DURA FLEXBALL® is laid spatially on three levels in a system of bends with low bending radii and is 97% effective, particularly under heavy payloads. Stainless steel inner components guarantee an optimal life-span with high fatigue resistance under reverse bending processes.

DURA FLEXBALL® replaces, in many cases, complex solid rods, hydraulic, pneumatic or electric transfer devices and also the energy supply machinery required to power them.

DURA FLEXBALL® is manufactured in lengths ready to install.

The advantages at a glance:

- Flexible
- Can be laid on three levels
- Works on compression and tension
 - Operation ratio almost 1
- No maintenance or lubrication necessary
 - Comfortable installation
- Indifferent to fluctuations in temperature
- Works reliably and without interruption, even at lengths of over 20 Meters and spatial laying

Design and Performance

- All metal parts are made from stainless steel
- Agraff tube with DYTRON coating, silicon coating for high temperature applications
- Special models possible

Type	55 ¹⁾	60 ¹⁾	80	95	125	160
Degree of efficiency	90%					
a) for small loads	97%					
b) for large loads						
min. installation radius ²⁾	80	100	120	140	200	250
Elastic deformation ³⁾ per m at 100 N load	0.3	0.18	0.16	0.1	0.05	0.05
Temperature range	- 40 to + 100 °C					
a) with Dytron coating	- 40 to + 300 °C					
b) without Dytron coating						

- 1) Type 55 is only available in lengths of up to 5 m, type 60 is available in lengths of up to 12m.
- 2) For rapid stroke sequences (over 40/min) to be installed in largest possible installation radius.

The following information is required when ordering

- DURA FLEXBALL® model (DZ, S3 etc. – see related data sheets)
 - DURA FLEXBALL® type (the choice of type is determined by the power to be transferred by the respective stroke)
 - Casing length G or the total length L (see reference edge measurements on the data sheets)
 - Required control lift (max. pin movement when moving in and out)
 - Possible prestress required for a total angle of over 180° (see below)
 - Type and number of accessories (yoke end, ball joint etc. - (see information sheets)
 - Possible attachment of transmission / reception elements - (see information sheets)
- Lifting sequence (double stroke per unit of time)

Laying examples with and without prestress

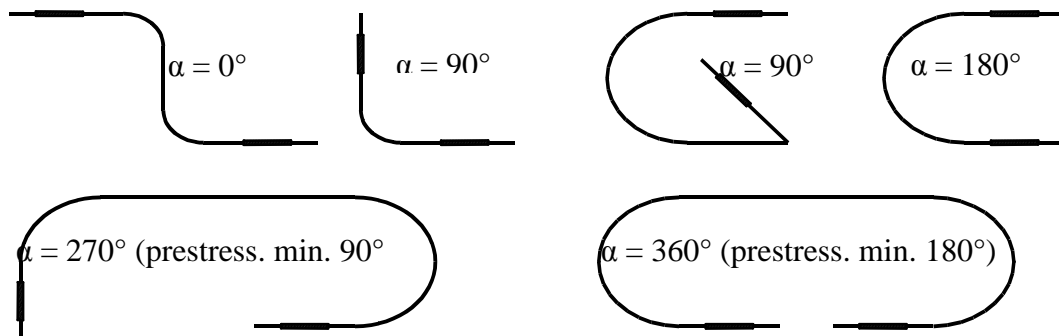

The assembly of DURA FLEXBALL® Remote Controls requires counter angle prestress compensation for angles greater than 180° (ie. negative angle).

DURA FLEXBALL® push-pull model „DZ“ (with set bolts and guide bushing)

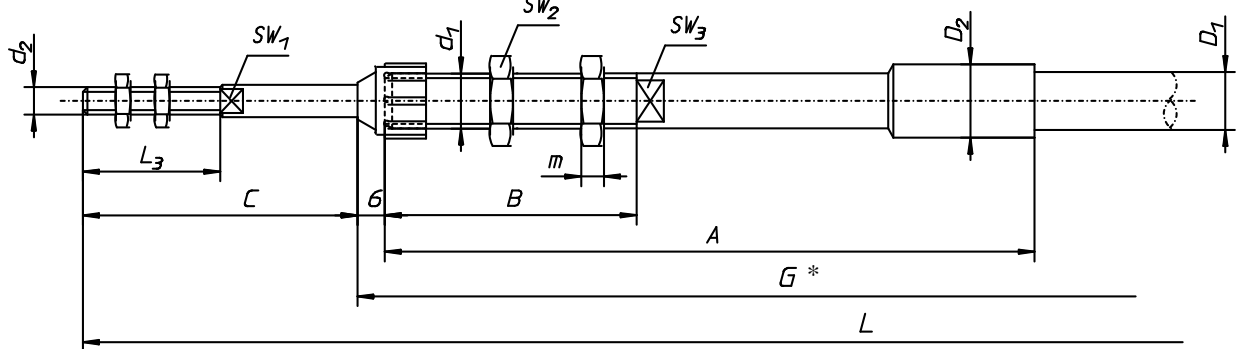

Order example: DZ 95, G* = 2000, H = 100

Type	Stroke	A	B	C	D1	D2	d1	d2	L3	m	Width across flats1	Width across flats2	Width across flats3	Operating load [N] max.		
														stroke	Pressure	traction**
55	-50	130	55	24 +	∅ 11	∅ 14	M10	M 5	20	4	4	14	8	-100	300	800
	-70	150	75	½ stroke			x1									
	-100	180	105													
60	-50	142	55	35 +	∅ 12.7	∅ 16	M 12x1	M 6	30	5	6	17	11	-100	1200	2500
	-70	162	75	½ stroke										-150	500	1250
	-100	192	105											-200	200	600
	-150	242	155													
	-200	292	205													
80	-50	146	55	35 +	∅ 14	∅ 18	M 14x1	M 8	30	8	7	22	13	-100	1400	2800
	-70	166	75	½ stroke										-150	600	1400
	-100	196	105											-200	250	700
	-150	246	155													
	-200	296	205													
95	-50	158	70	38 +	∅ 15.5	∅ 19	M 16x1.5	M 10	30	8	9	24	14	-100	2500	5000
	-70	178	90	½ stroke										-150	1400	2500
	-100	208	120											-200	600	1250
	-150	258	170													
	-200	308	220													
125	-50	186	74	41 +	∅ 20.5	∅ 24	M 18x1.5	M 12x1.5	35	9	11	27	17	-100	5000	10000
	-70	206	94	½ stroke										-150	2500	5000
	-100	236	124											-200	1200	2500
	-150	286	174													
	-200	336	224													
160	-50	228	100	41 +	∅ 24	∅ 28	M 22x1.5	M 14x1.5	35	10	13	32	20	-100	6000	15000
	-70	248	120	½ stroke										-150	3000	7500
	-100	278	150											-200	1500	3750
	-150	328	200													
	-200	378	250													

* shortest DURA FLEXBALL® length $G = 2A + 200 + \text{elbow length} + \text{stroke}$

** The traction values given are only valid for the prestress on the „installation angle“!

For long-term stress in the max. Stress field, the next largest type should be chosen.

For fringe range payloads, please consult our advisory service.

DURA FLEXBALL® pull model „S3“ (cable end and pins)

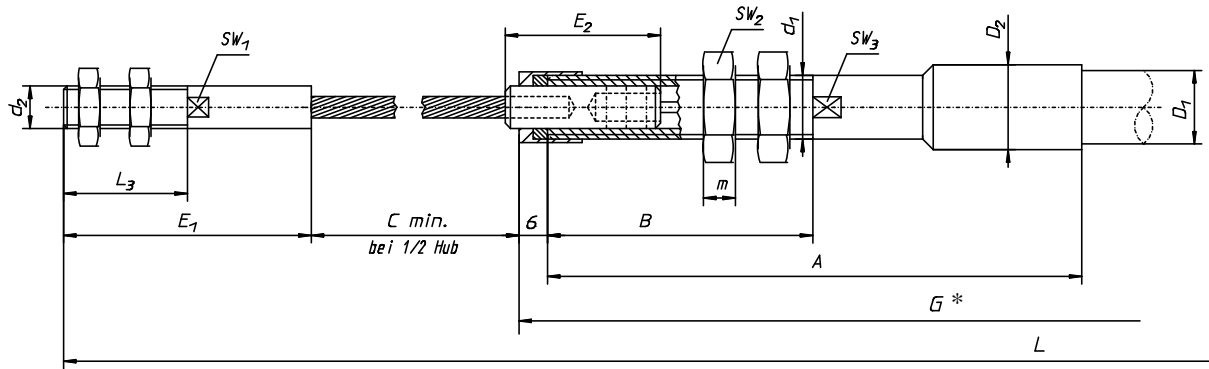

Order example: S3 80, G* = 1200, H = 50, C measurement (if > than Cmin.)

Type	Stroke	d1	d2	A	B	Cmin	D1	D2	D3	E1	E2	L3	m	Width across flats1	Width across flats2	Width across flats3	Operating load [N] max.**
60	-50	M12x1	M6	142	55	115	Ø12.7	Ø16	Ø3.5	50	44	30	5	6	17	11	2500
	-70			162	75	125											2500
	-100			192	105	140											2500
	-150			242	155	165											1250
	-200			292	205	190											600
80	-50	M14x1	M8	146	55	115	Ø14	Ø18	Ø3.5	50	44	30	8	7	22	13	2800
	-70			166	75	125											2800
	-100			196	105	140											2800
	-150			246	155	165											1400
	-200			296	205	190											700
95	-50	M16x1.5	M10	158	70	120	Ø15.5	Ø19	Ø5	55	47	30	8	9	24	14	5000
	-70			178	90	130											5000
	-100			208	120	145											5000
	-150			258	170	170											2500
	-200			308	220	195											1250

* shortest DURA FLEXBALL® length $G = 2A + 200 + \text{elbow length} + \text{stroke}$

** The traction values given are only valid for the priestess on the „installation angle“!
 For long-term stress in the max. Stress field, the next largest type should be chosen.

For fringe range payloads, please consult our advisory service.

DURA FLEXBALL® traction model „T3“ (free cable end)

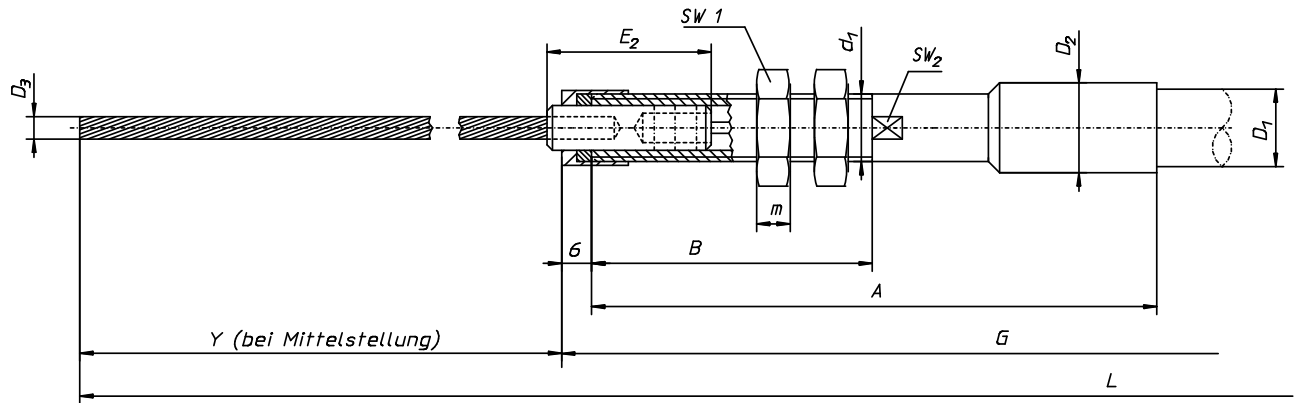

Order example: T3 80, G* =1200, H=50, (according to installation requirements)

Type	Stroke	A	B	d1	D1	D2	D3	E2	m	Width across flats1	Width across flats2	Operating load [N] max.**
60	-50	142	55	M12x1	Ø12.7	Ø16	Ø3.5	44	5	17	11	2500
	-70	162	75									2500
	-100	192	105									2500
	-150	242	155									1250
	-200	292	205									600
80	-50	146	55	M14x1	Ø14	Ø18	Ø3.5	44	8	22	13	2800
	-70	166	75									2800
	-100	196	105									2800
	-150	246	155									1400
	-200	296	205									700
95	-50	158	70	M16x1.5	Ø15.5	Ø19	Ø5	47	8	24	14	5000
	-70	178	90									5000
	-100	208	120									5000
	-150	258	170									2500
	-200	308	220									1250

* shortest DURA FLEXBALL® length $G = 2A + 200 + \text{elbow length} + \text{stroke}$

** The traction values given are only valid for the prestress on the „installation angle“!
 For long-term stress in the max. Stress field, the next largest type should be chosen.

For fringe range payloads, please consult our advisory service

DURA FLEXBALL® traction model „Z3“
 (free emerging central plate with end pins
 and pipe socket with threaded setting)

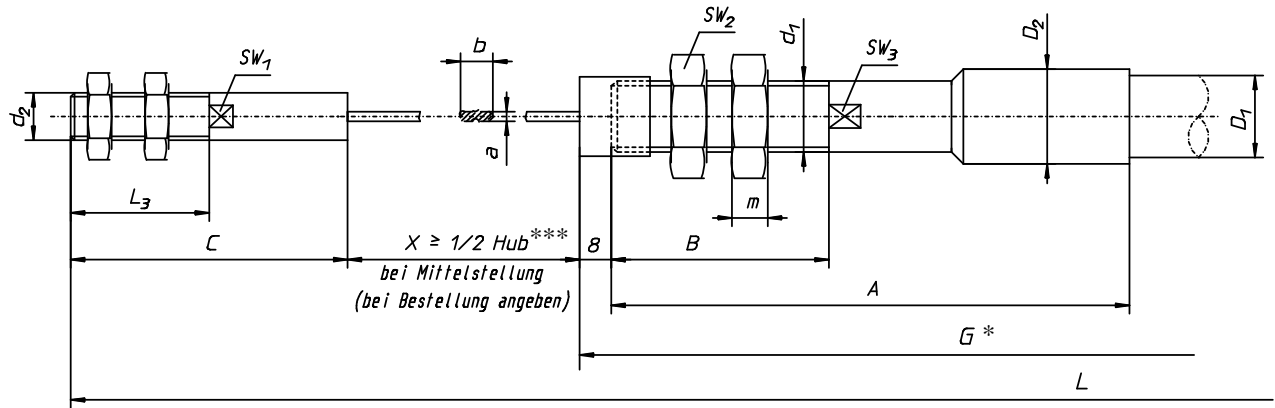

Order example: Z3 125, G* = 3000, H* = 150, X (please specify)**

Type	d1	d2	A	B	C	D1	D2	L3	m	a x b	Width across flats1	Width across flats2	Width across flats3	Operating load [N] max.**
60	M12x1	M6 M8	87	35	54	Ø12.7	Ø16	30	5	1.35x5	6	17	11	2500
80	M14x1	M8 M10	87	35	54	Ø14	Ø18	30	8	1.5x6	7	22	13	2800
95	M16x1.5	M10 M12x1.5	128	50	70	Ø15.5	Ø19	35	8	1.7x7	9	24	18	5000
125	M18x1.5	M12x1.5	150	56	70	Ø20.5	Ø24	35	9	2.5x8.2	11	27	22	10000

* shortest DURA FLEXBALL® length $G = 2A + 200 + \text{elbow length} + \text{stroke}$

** The traction values given are only valid for the prestress on the „installation angle“!
 For long-term stress in the max. Stress field, the next largest type should be chosen.

*** For strokes over 200mm, please consult our consulting service.

DURA FLEXBALL® traction model „Z4“
 (free emerging central plate with end pins
 and plug-in pipe connection)

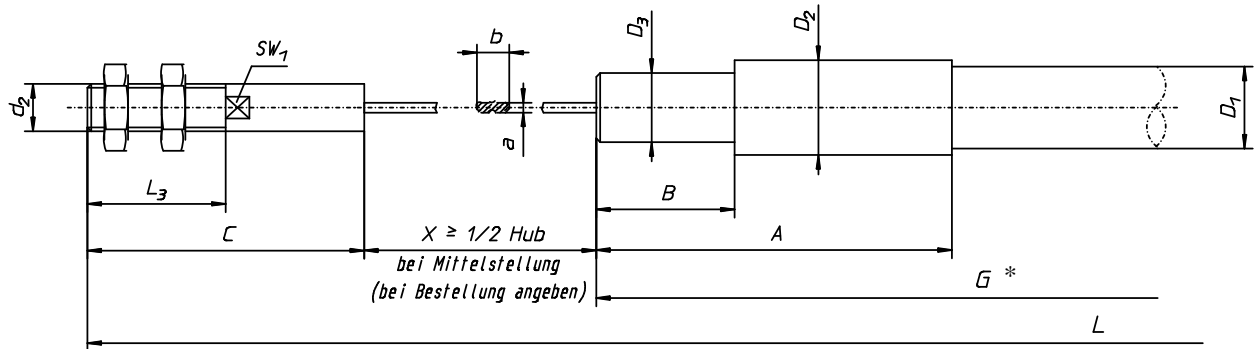

Order example: Z4 80, G* =5000, H* =100, X and d2 (please specify)**

Type	d2	A	B	C	D1	D2	D3	L3	a x b	Width across flats ¹	Operating load [N] max. ^{**}
60	M6 M8	50	23	54	Ø12.7	Ø16	Ø11	30	1.35x5	6	2500
80	M8 M10	50	23	54	Ø14	Ø18	Ø14	30	1.5x6	7	2800
95	M10 M12x1.5	68	25	70	Ø15.5	Ø19	Ø14.5	35	1.7x7	9	5000
125	M12x1.5	90	35	70	Ø20.5	Ø24	Ø17.5	35	2.5x8.2	11	10000

- * shortest DURA FLEXBALL® length $G = 2A + 200 + \text{elbow length} + \text{stroke}$
- ** The traction values given are only valid for the prestress on the „installation angle“!
 For long-term stress in the max. Stress field, the next largest type should be chosen.
- *** For strokes over 200mm please consult our advisory service.

For special constructions, please consult our advisory service.

Ball joint

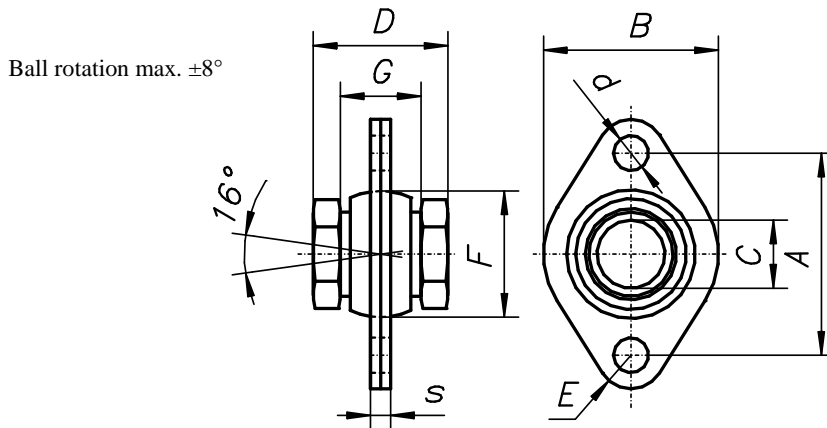

Lubricate ball joints at intervals

For type	A	B	C	d	D	E	F	G	s	Width across flats	Order no.
55	30	26	10.1	5.2	20	5	19.5	12	3	14	1128 001 A24
60	40	30	12.1	6.4	26	7	25	16	4	17	1128 001 B24
80	40	31	14.1	6.4	32	7	26	16	4	22	1128 001 C24
95	52	42	16.1	8.5	38	10	34	22	5	24	1128 001 D24
125	56	45	18.1	8.5	43	10	36	25	5	27	1128 001 E24
125*	60	59	18.1	1.2	45	10	36	27	16	27	1128 030 E24
160	60	59	22.1	10.2	47	10	40	27	16	32	1128 001 F24

* For payloads from 5000 to 10000 N

Ball joints are available for all DURA FLEXBALL® types. Types with guiding bushing swing out the possible existing amplitude of the lever in question (see draft below).

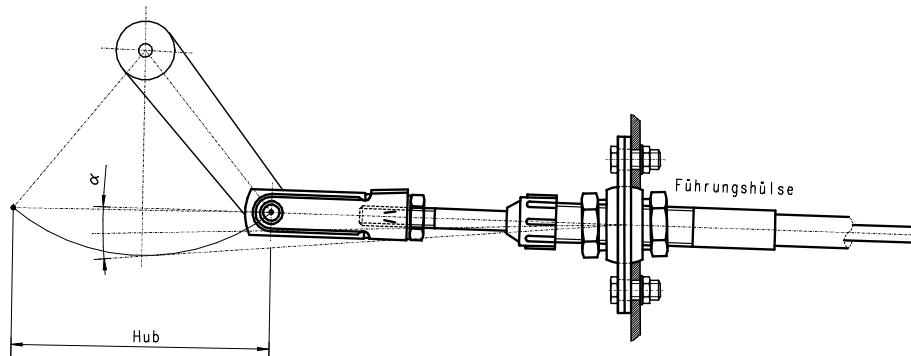

Assembly instruction:

The position of the ball joint at the abutment should be mediated with the lever amplitude. Angle amplitude of the guiding bushing = $\alpha/2$, but not more than $\alpha = \pm 8^\circ$ (see draft).

Secure toggle joint of the guiding bushing as far to the back of the thread end as possible, to achieve the minimum possible out swing.

Angle joint

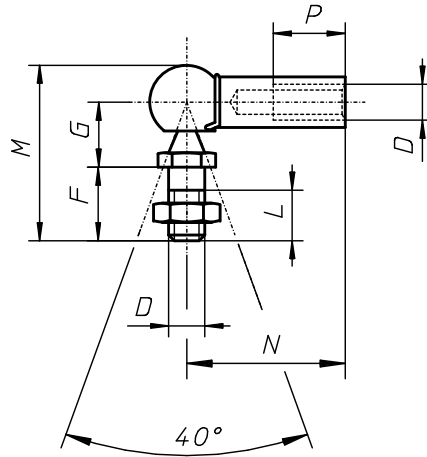

For type	D	F	G	L	N	P	M	Order no.
55	M5	10.2	9	7	22	10.2	25.2	1750001A10
60	M6	12.5	11	8	25	11.5	30.2	1750001B10
80	M8	16.5	13	12	30	14	39.5	1750003B10
95	M10	20	16	14	35	15.5	47.5	1750001D10
125	M12x1.5*	20	16	14	35	15.5	47.5	1750001E10

* on pin M10

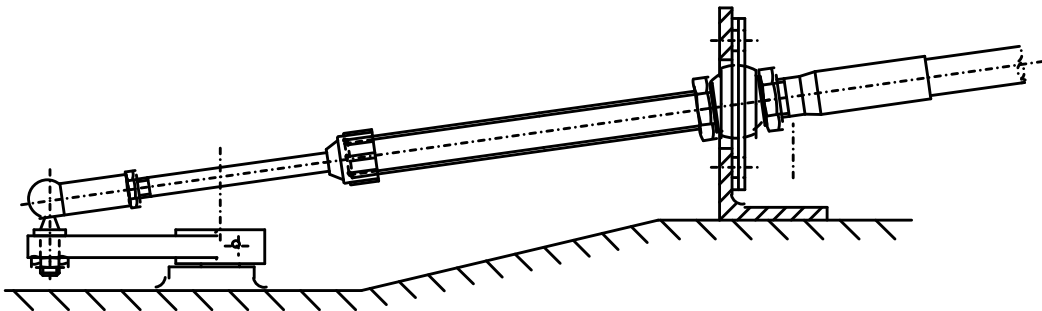

Clevis

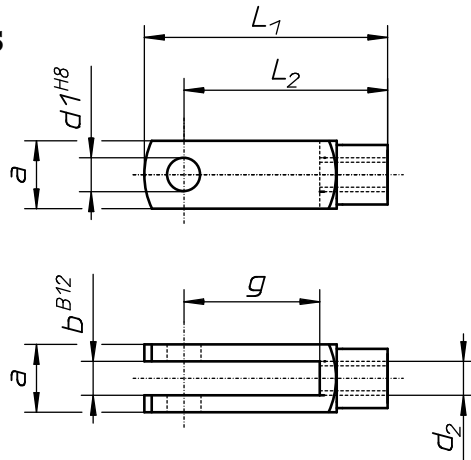

ES pins

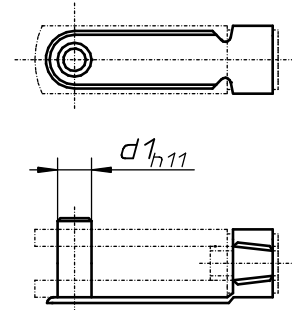

For type	a	b	d ₁	d ₂	g	L ₁	L ₂	Fork (DIN 71752)			ES pins	
								Order desc.	Order no. Without ES pins	Order no. with ES pins	Order desc.	Order no.
55	10	5	5	M5	10	26	20	G 5x10	1741 001 A10	1741 101 A10	ESN01 5x10	1742 001 A10
								G 5x20	1741 002 A10	1741 102 A10	ESN01 5x20	1742 002 A10
60	12	6	6	M6	12	31	24	G 6x12	1741 001 B10	1741 101 B10	ESN01 6x12	1742 001 B10
								G 6x24	1741 002 B10	1741 102 B10	ESN01 6x24	1742 002 B10
80	16	8	8	M8	16	42	32	G 8x16	1741 005 B10	1741 105 B10	ESN01 8x16	1742 003 B10
								G 8x32	1741 007 B10	1741 107 B10	ESN01 8x32	1742 004 B10
95	20	10	10	M10	20	52	40	G 10x20	1741 001 D10	1741 101 D10	ESN01 10x20	1742 003 B10
								G 10x40	1741 002 D10	1741 102 D10	ESN01 8x32	1742 004 B10
125	24	12	12	M12x1.5	24	62	48	G 12x24	1741 001 E10	1741 101 E10	ESN01 8x16	1742 003 B10
								G 12x48	1741 002 E10	1741 102 E10	ESN01 8x32	1742 004 B10
160	27	14	14	M14x1.5	28	72	56	G 14x28	1741 001 F10	1741 101 F10	ESN01 8x16	1742 003 B10
								G 14x56	1741 002 F10	1741 102 F10	ESN01 8x32	1742 004 B10

Ring eye

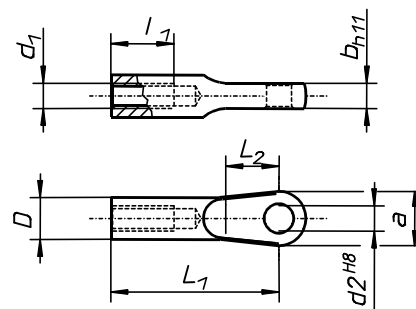

For type	a	b	d ₁	d ₂	D	I ₁	L ₁	L ₂	Order no.
55	10	5	M5	5	8	15	35	10	1023 001 A14
60	12	6	M6	6	10	20	40	8	1023 001 B14
80	16	8	M8	8	12	20	46	14	1023 027 B14
95	20	10	M10	10	16	30	55	14	1023 001 D14
125	24	12	M12x1.5	12	18	30	60	22	1023 001E14
160	28	14	M14x1.5	14	20	30	70	22	1023 001 F14

Fine adjustment

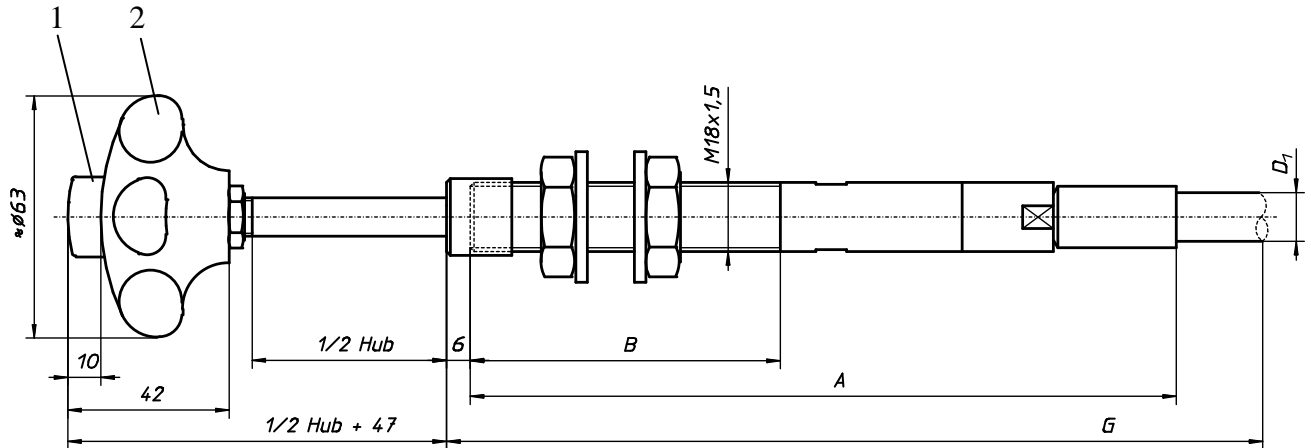

1) Release button for coarse feed

By pressing the coarse feed button, all inter-degree pressure and pull adjustments can be fixed.

2) Hand button for fine adjustment

Fine adjustment is affected by turning the hand button;
 1 turn = 4 mm stroke

Type	stroke	A		B	D ₁		Operating load [N] max.
		FLEXBALL	DURAFLEX		FLEXBALL	FURAFLEX	
60	-50	192	210	55	Ø 12.7	Ø 11.5	100
	-70	212	230	75			
	-100	242	260	105			
	-150	292	310	155			
	-200	342	360	205			
80	-50	192	210	55	Ø 14	Ø 14	100
	-70	212	230	75			
	-100	242	260	105			
	-150	292	310	155			
	-200	342	360	205			
95	-50	197		55	Ø 15.5	-	100
	-70	217		75			
	-100	247	-	105			
	-150	297		155			
	-200	347		205			

Control lever

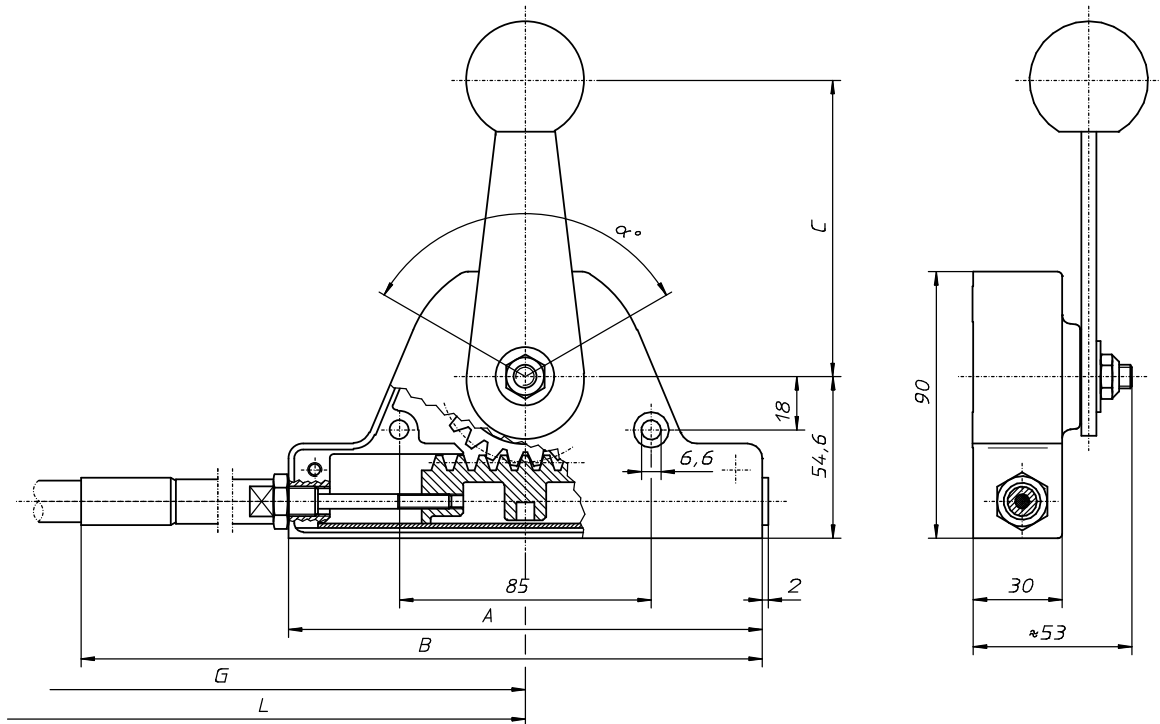

Types available:

- Smooth controls, with and without lock
- Assembly as single or double control lever
- Connection possible to the right, left or to both sides
- The slewing range of the lever can be relocated as desired
- Ball stop also available

Technical data:

- Steeple adjustment of friction lock
- Type with free wheel lock is self-locking up to 300 N
- Payload for push and pull functions max. 800 N
- Vibration-safe and dust-protected
- Die-cast housing; steel parts are zinc coated

For type	stroke up to	Order Number			A	B	C	i	α
		Finger-tip control	Friction lock	Free wheel lock					
55	60	3860 001 K02	3860 021 K02	3861 001 K02	160	232	100	1:3.5	120°
	80	3880 001 K02	3880 021 K02	3881 001 K02	195	267	175	1:6	160°
60	60	3860 004 K02	3860 024 K02	3861 004 K02	160	232	100	1:3.5	120°
	80	3880 004 K02	3880 024 K02	3881 004 K02	195	267	175	1:6	160°
80	60	3860 005 K02	3860 025 K02	3861 005 K02	160	232	100	1:3.5	120°
	80	3880 005 K02	3880 025 K02	3881 005 K02	195	267	175	1:6	160°

Control lever with friction lock

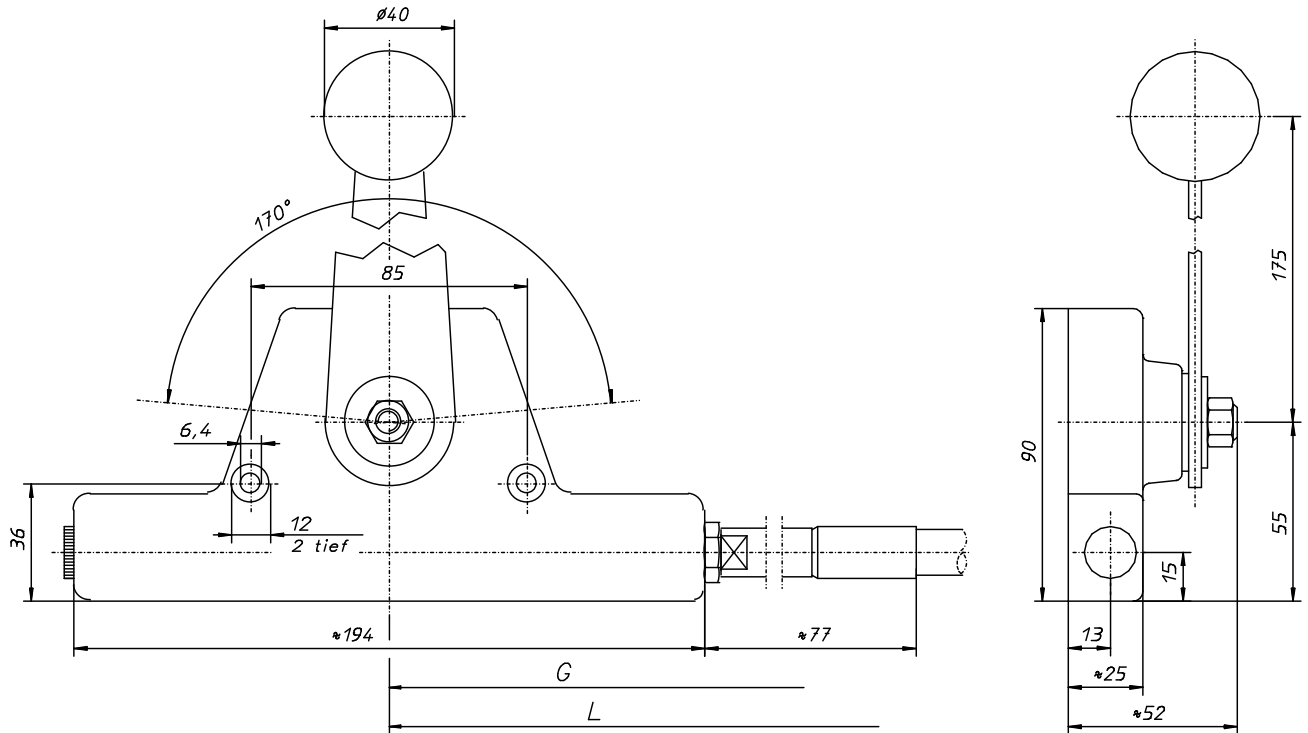

Types available:

- Assembly as single or double control lever
- Right, left or both sided connection
- The slewing range of the lever can be relocated as desired
- Steeples adjustment of friction lock

Technical data:

- Payload for push and pull functions max. 500 N
- Stroke 80 mm
- Transmission gear ratio 1:5
- Vibration-safe and dust-protected
- Die-cast housing; steel parts are zinc coated

For type	Order no.
55	3842 008 K02
60	3842 010 K02
80	3842 011 K02

Control lever with and without lock

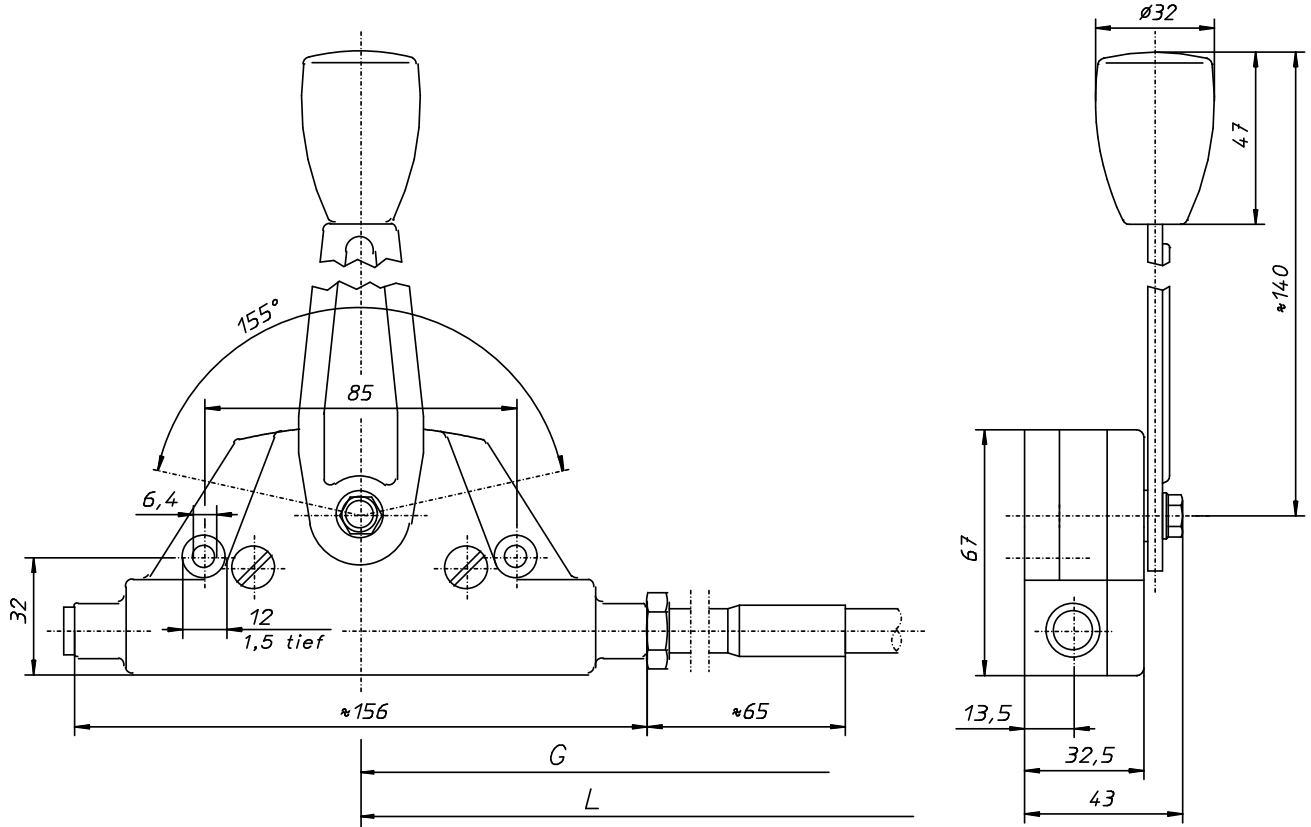

Types available:

- Assembly as single or double control lever
- Right, left or both sided connection possible
- The slewing range of the lever can be relocated as desired

Technical data:

- Type with lock self-locking up to 300 N
- Payload for push and pull functions max. 300 N
- Stroke 60 mm
- Transmission gear ratio 1:5
- Vibration-safe, dustproof and waterproof
- Die-cast housing; steel parts are zinc coated

For type	Order Number	
	Without lock	With lock
55	3842 004 K02	3842 005 K02
60	3842 006 K02	3842 007 K02

Control lever with graduated lock

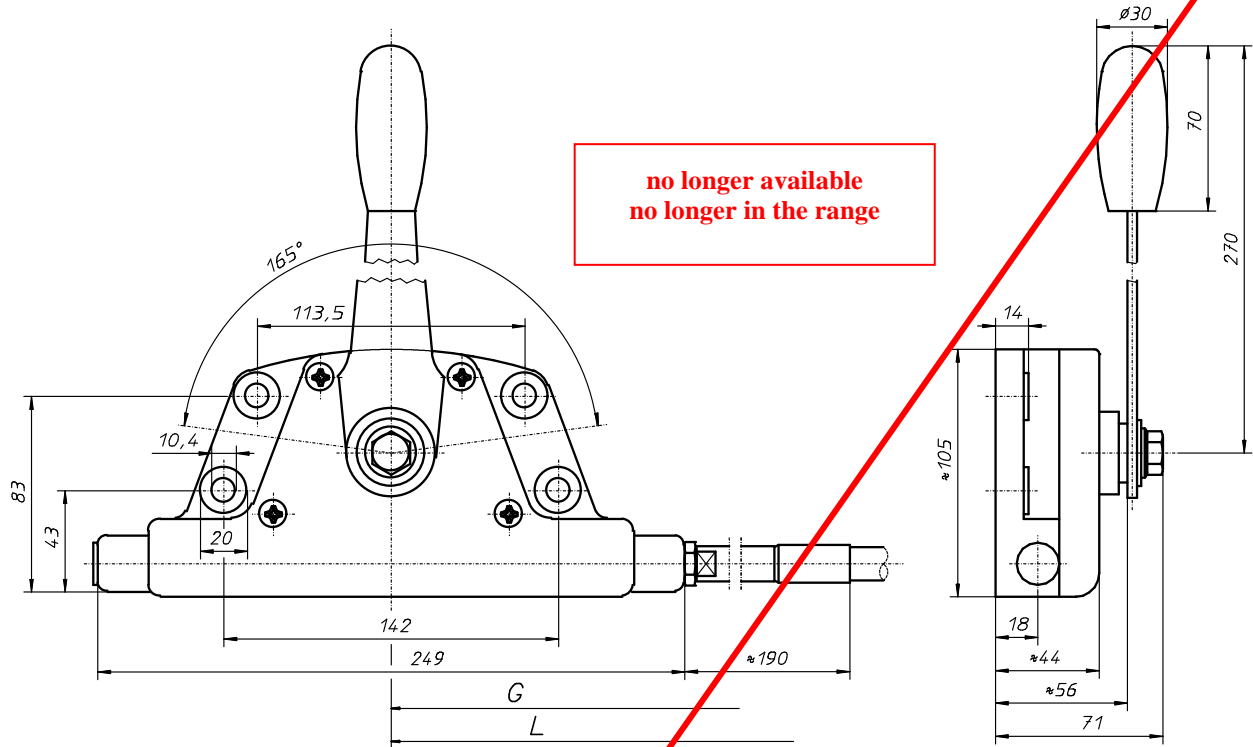

Types available:

- Assembly as single or double control lever
- Right, left or to both sided connection possible
- Slewing range of lever can be relocated as desired

Technical data:

- Model with lock self-locking up to 500 N
- Payload for push and pull functions max. 500 N
- Stroke 100 mm (graduated locking 3.5 mm)
- Transmission gear ratio 1:7
- Vibration-safe, dustproof and waterproof
- Die-cast housing; steel parts are zinc coated

Model	Order no.
without lock	3845 001 K00
with lock	3845 003 K00

Gear rack box type 035 (Transmission box model)

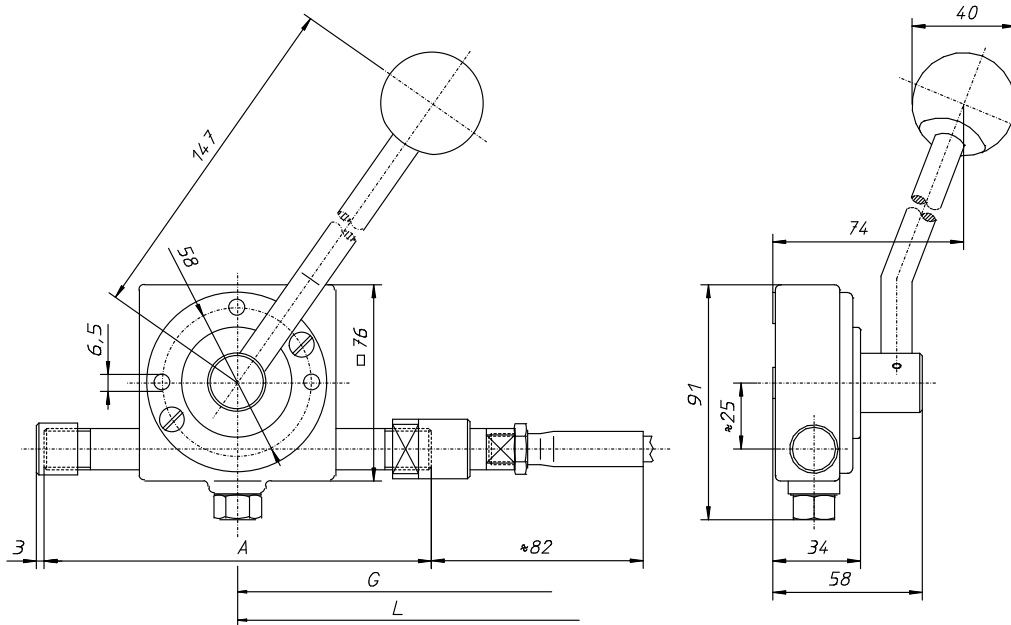

The gear rack box 035 model „**transmission box**“ is a universally adjustable transmission element with a max. stroke of 150 mm. Lever amplitude of 2.48° corresponds to 1 mm stroke. (Special types with 4 connections, different lever lengths and push-in fishplate are also possible.)

Order no. for standard models			
Stroke	A	Connection for type 60	Connection for type 80
50	150	3935 001 B02	3935 001 C02
75	200	3935 002 B02	3935 002 C02
100	250	3935 003 B02	3935 003 C02
125	300	3935 004 B02	3935 004 C02
150	350	3935 005 B02	3935 005 C02

Order no. for models with ball stop (indicate ball stop position when ordering)			
Stroke	A	Connection for type 60	Connection for type 80
50	150	3935 011 B02	3935 011 C02
75	200	3935 012 B02	3935 012 C02
100	250	3935 013 B02	3935 013 C02
125	300	3935 014 B02	3935 014 C02
150	350	3935 015 B02	3935 015 C02

Gear rack box type 035 with friction lock (transmission box type)

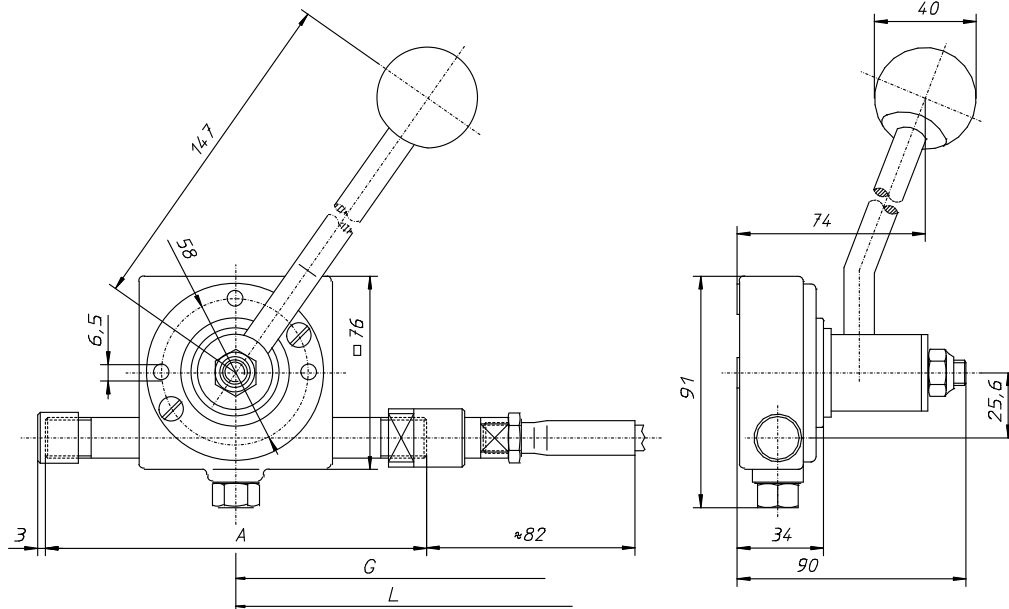

The gear rack box 035 model „**Transmission box with friction lock**“ is a universally adjustable transmission element with an infinitely variable friction lock and a max. Stroke of 150 mm. The max. hold of the friction lock is 300N. Lever amplitude of 2.48° corresponds to 1 mm stroke. (Special types with 4 connections, different lever lengths and push-in fishplates are also possible).

Order no. for models with friction lock			
Stroke	A	Connection for type 60	Connection for type 80
50	150	3935 191 B02	3935 191 C02
75	200	3935 192 B02	3935 192 C02
100	250	3935 193 B02	3935 193 C02
125	300	3935 194 B02	3935 194 C02
150	350	3935 195 B02	3935 195 C02

Order no. for models with friction lock and ball stop (indicate ball stop position when ordering)			
Stroke	A	Connection for type 60	Connection for type 80
50	150	3935 196 B02	3935 196 C02
75	200	3935 197 B02	3935 197 C02
100	250	3935 198 B02	3935 198 C02
125	300	3935 199 B02	3935 199 C02
150	350	3935 200 B02	3935 200 C02

Gear rack box type 035 (receiver box type)

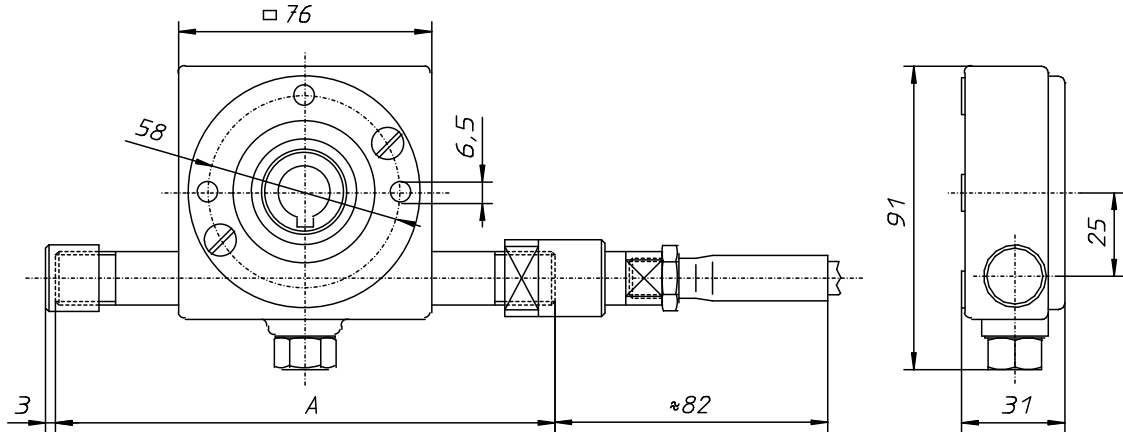

The gear rack box 035 model „receiver box“ largely corresponds to the transmission box model. Drilled pinion hole diameter: Ø14mm (special drilled diameters on request)

Order no. for standard models			
Stroke	A	Connection for type 60	Connection for type 80
50	150	3935 051 B02	3935 051 C02
75	200	3935 052 B02	3935 052 C02
100	250	3935 053 B02	3935 053 C02
125	300	3935 054 B02	3935 054 C02
150	350	3935 055 B02	3935 055 C02

Order number for models with ball stop (indicate ball stop position when ordering)			
Stroke	A	Connection for type 60	Connection for type 80
50	150	3935 041 B02	3935 041 C02
75	200	3935 042 B02	3935 042 C02
100	250	3935 043 B02	3935 043 C02
125	300	3935 044 B02	3935 044 C02
150	350	3935 045 B02	3935 045 C02

DURA FLEXBALL® universal gear rack box (basic box No. 6)

The universal gear rack box (basic box no. 6) is available for DURA FLEXBALL® models up to and including model 80. It can be used as a transmitter (with operating handle), as a receiver or as a splitter. It features one or two gear racks and enables the connection of up to four controls. Two or more boxes can be arranged next to one another on the same shaft.

Basic box no.	TK-Ø	Z	m	max. payload	1 mm stroke =
6	48	48	1	150 N	2.39°

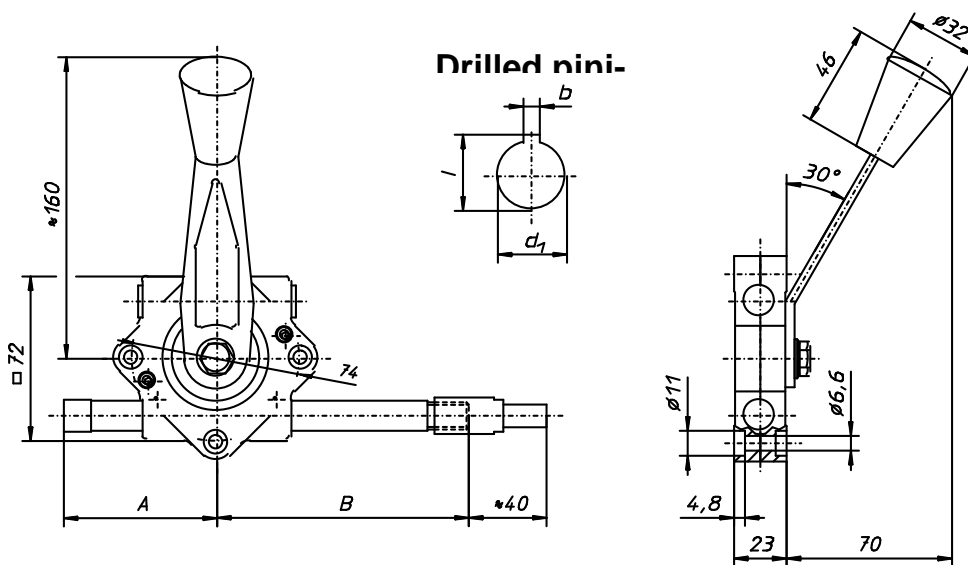

Note:

Always order controls corresponding to the respective gear rack box, since a special connection is required.

Drilled hole conductor length		
stroke	A	B
-50	67	110
-70	87	130
-100	117	160
-150	177	220

Permissible pushing force[N]			
Type	Stroke 70	Stroke 100	Stroke 150
55	150	100	–
60	150	150	150
80	150	150	150

Drilled pinion hole optional		
d1	I	b
Ø12 ^{H7}	13.8	4 ^{P9}
Ø14 ^{H7}	16.3	5 ^{P9}
Ø16 ^{H7}	18.3	5 ^{P9}

DURA FLEXBALL® universal gear rack box (basic box no. 7, 8 and 9)

Universal gear rack boxes are available for DURA FLEXBALL® models 60 to 125. They can be used as transmitters (with operating handle shown on information sheet 1.20), as receivers or as splitters. They feature one or two gear racks and enable the connection of up to four controls. To achieve different strokes, universal gear rack boxes of different sizes can be combined with each other (changing the transmission ratio). The number of control connections is increased at the same time.

Basic box no.	Drilled pinion hole						N	max. operating load [N]	1 mm stroke =
		H	J	K	m	Z			
7	102	16	18.2	5	1.5	68	52	600	1.123°
8	72	16	18.2	5	1.5	48	37	600	1.591°
9	84	16 40	18.2 43.2	5 12	1.5	56	43	2000	1.36°

Materials: Casing GDAlMg9 hard coated all round; connection parts made from galvanised steel. High strength brass also available upon request.

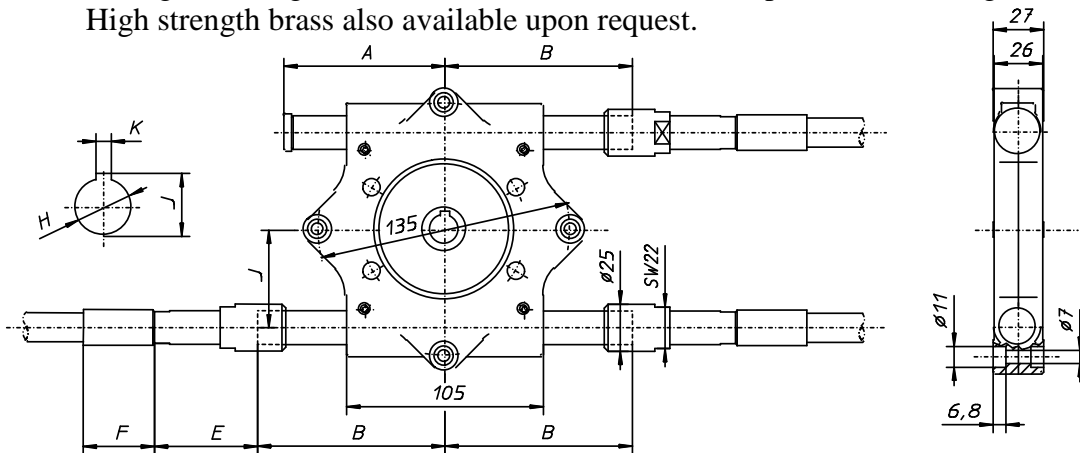

Note:

Always order controls corresponding to the respective gear rack box, since a special connection is required.

Type	E	F
60	45	32
80	45	32
95	55	38
125	66	45

Stroke	A	B
-50	86	100
-70	106	120
-100	136	150
-150	186	200
-200	236	250

Permissible pushing force [N]								
Basic box no. 7 and 8					Basic box no. 9			
Type	Stroke 70	Stroke 100	Stroke 150	Stroke 200	Stroke 70	Stroke 100	Stroke 150	Stroke 200
60	500	400	250	–	500	400	250	–
80	500	400	250	–	500	400	250	–
95	600	600	500	400	1300	1000	500	400
125	600	600	500	600	2000	1500	1300	1000

Control lever for universal gear rack boxes

Lever without lock
(1965 ...)

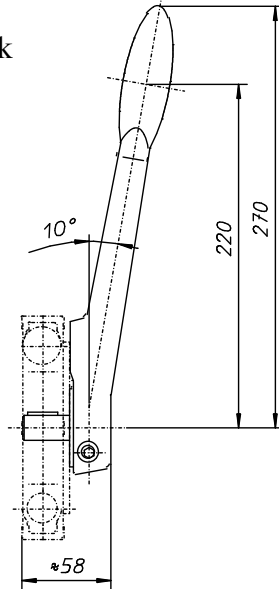

Lever with graduated
lock
(1966 ...)

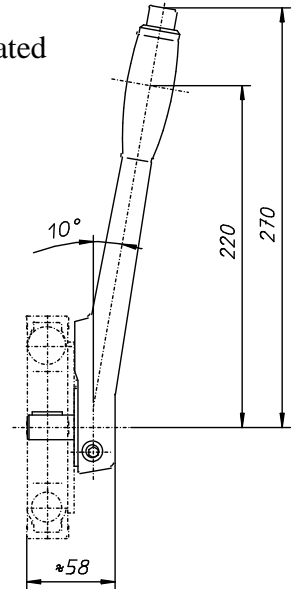

Lever with locking
device
(1967 ...)

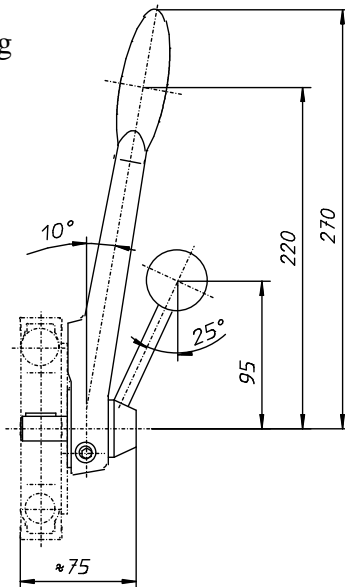

Lever without lock
(1968 ... and 1969 ...)

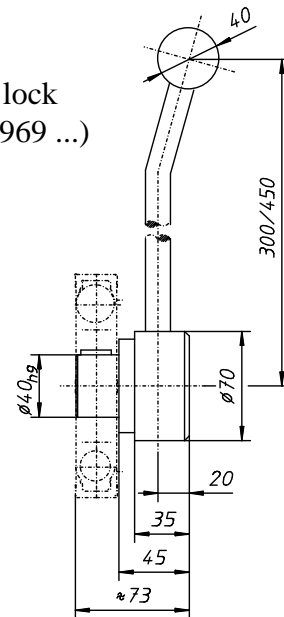

Order number		For Z box basic no.	Locking	Lever length	Payload [N]
Without indica-	With indicator				
1965 001 0	1965 002 0	7, 8 & 9	none	270	300
1966 001 0	1966 002 0	7, 8 & 9	locking 5°	270	300
1967 001 0	1967 002 0	7 & 8	locking handle	270	300
1968 001 0	1968 002 0	9	none	300	1300
1969 001 0	1969 002 0	9	none	450	2000

Single valve transmitter

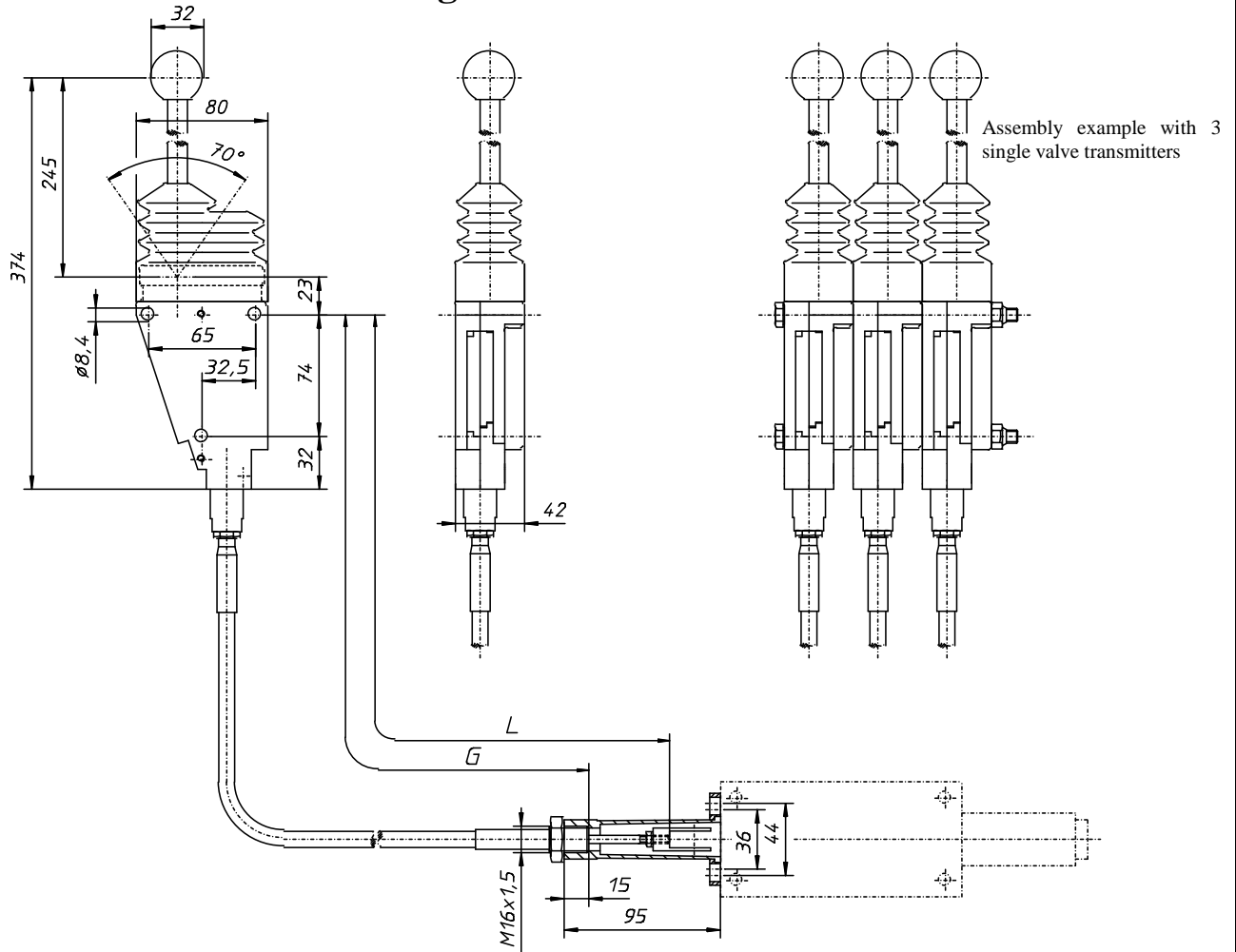

Valve transmission with the corresponding remote control allows the smooth and easy operation of hydraulic valves, independently from their installation position in the vehicle or engine. The max. Stroke is 40 mm (± 20 mm). The stroke central position is fixed by spring resistance. Installation can be carried out singly or as a block of several transmitters (see assembly example). Special models, such as e.g. different lever lengths, are possible on request.

The connection bell on the valve guarantees simple, space-saving fastening to the remote control cable and renders costly abutment unnecessary.

Note: This transmission box can also be used when spring-supported central (neutral) position is needed.

For type	Order no.	
	Stroke 30 mm i=1:9	Stroke 40 mm i=1:6.6
55	3846 001 R01	3846 002 R01
60	3846 001 S01	3846 002 S01

Double valve transmitter

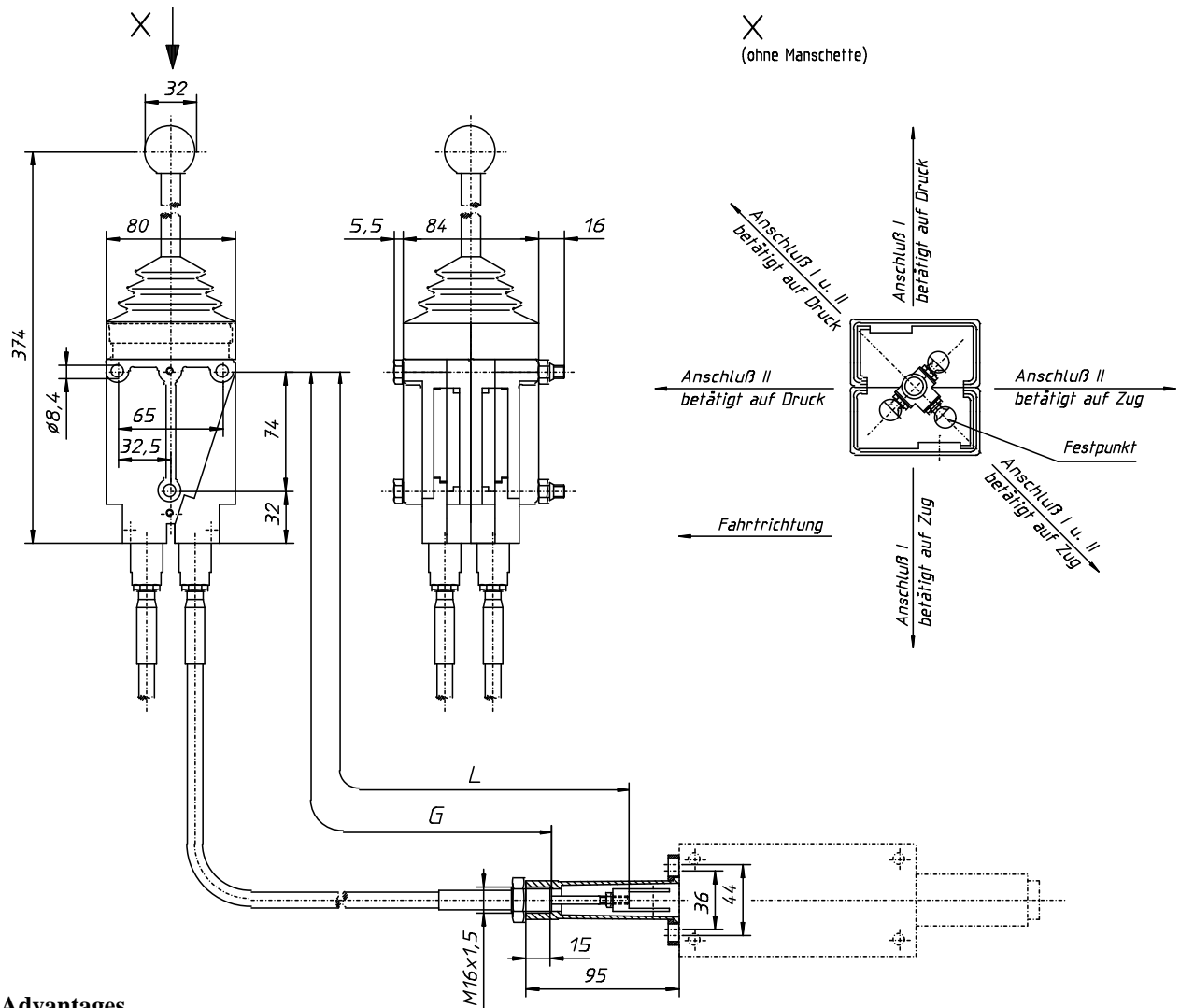

Advantages

- Smooth and easy operation of 2 hydraulic valves with a single lever
- Simple and secure space-saving attachment of remote control, rendering costly abutment unnecessary
- Functions independently from the installation position
- Possible combination of 2 double valves (corner molding of lever stick recommended)

Technical Data:

- Stroke max. 30 mm (±15 mm)
- Stroke central position (neutral position) fixed by spring resistance

Note

This transmission box can be used at times when it is of advantage to control two functions with one hand at the same time (for example 2 hydrostatics for a crawler device).

For type	Order no.
55	3846 003 R01
60	3846 003 S01

Accelerator pedal

Accelerator pedals are generally used for speed control in the usual way and for the movement of hydrostatic driving gear:

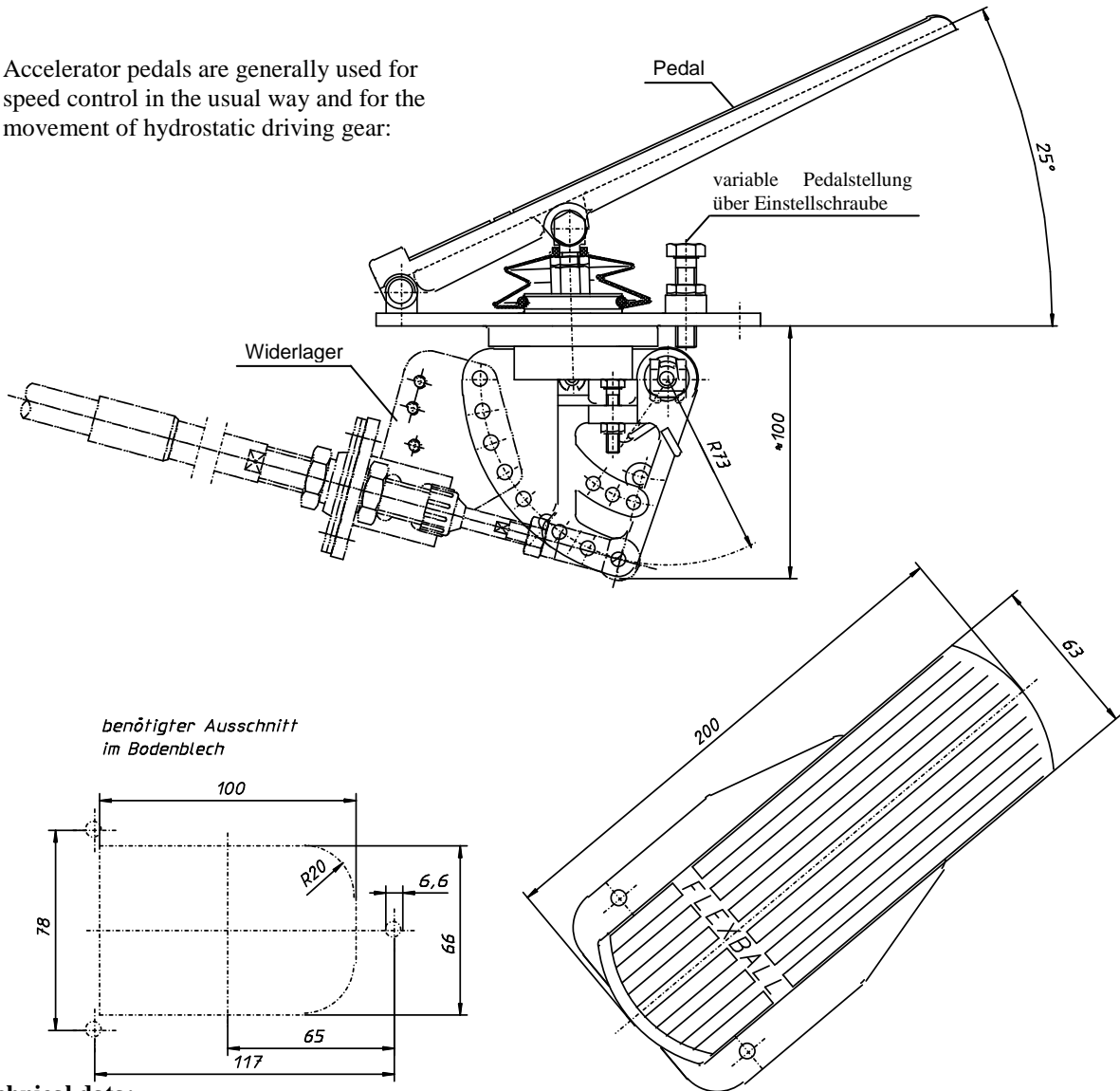

Technical data:

- Stroke according to pedal and stop position max. 70 mm
- Active line of connected remote controls firmly position able at 360° opposite the direction of movement (pedal)
- Incline of the abutment can be relocated opposite the base plate
- Connection to VOFAFLEX types 4, 5, 6 and cable pull

Supplementary accessories:

- Push- or pull-operated accelerator hand control (chosen number of rpm is sustained)

Note

The requirements of the ergonomics standardizing body were carefully considered during construction, to guarantee a high degree of fatigue-free operation.

Order no.
3847 001 K01

The choice of abutment is dependent on the type! Please consult our consulting service.