

KEENSERTS®

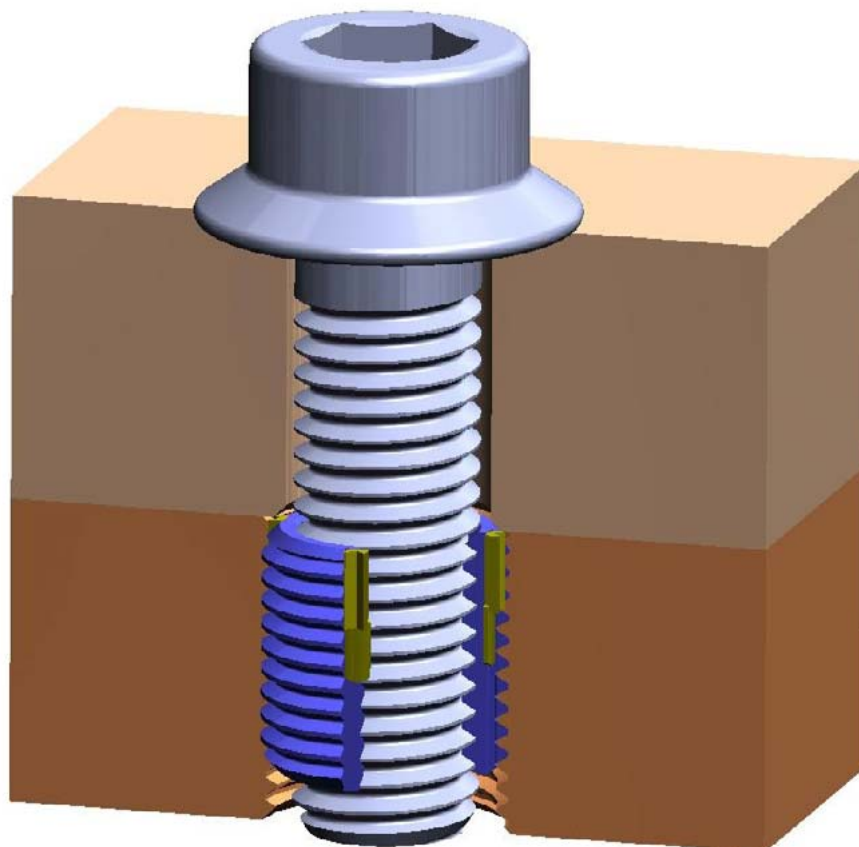

Page

General Information	A-2
Features of KEENSERTS ®	A-3 - A-4
Installation Instructions	A-5
KNCM Series (miniature inserts metric).....	B-1
KNM Series (lightweight inserts metric).....	B-2
KNHM Series (heavy duty inserts metric).....	B-3 - B-4
KNCA Series (miniature inserts imperial).....	C-1
KNJ Series (lightweight inserts imperial).....	C-2 - C-3
KNHJ Series (heavy duty inserts imperial).....	C-4 - C-7
KNHXHJ Series (extra heavy duty inserts imperial).....	C-8 - C-11



The Camloc brand was established in 1937. Since that time our fastening systems have been successfully integrated into numerous applications within many different industries.

Our customers benefit from our more than 75 years of fastening experience.

We provide local support for innovative, high quality fastening systems supplied globally to the strictest environmental and working conditions.



ISO/TS 16949: 2009



DIN EN ISO 14001 : 2004

Please find additional information about our environmental program under: www.alcoa.com.

Your Alcoa Fastening Systems team

Disclaimer:

Parts listed are subject to technical changes. All dimensions in mm. All information is correct to the best of our knowledge at the time of printing. No liability for disadvantages caused by printing errors or false application.

Threaded Inserts

KEENSERTS[®] are high strength threaded inserts made from stainless steel 1.4305 or AISI303. They are passivated according to EN 2516 or AMS 2700. Our **KEENSERTS**[®] standard product range contains metric and imperial thread dimensions. Specials are available upon request.

KEENSERTS[®] can be used in alloys, light materials, steel and cast iron to give increased thread strength in these low strength materials. They are also be used for thread repair enabling the damaged thread to be replaced with the same size thread.

KEENSERTS[®] Solid configuration gives a high cycle life with multiple tightening and loosening of the bolt. Locking inserts have a dry film lubrication on the surface to protect the screw from galling.

KEENSERTS[®] have a positive mechanical lock against rotation and vibration when kees are installed. Kees are made from stainless steel AISI302.

KEENSERTS[®] have 2 or 4 pre-assembled kees depending on the size of the external thread. After installation of the kees into the parent material the assembly is positively locked in place.

Pull-out-strength for **KEENSERTS**[®]. Calculation is as follows:

Pull-out-strength(N) = shear engagement (mm²) x ultimate shear strength of parent material (N/mm²)
Shear engagement areas are shown on the **KEENSERTS**[®] data sheets, only valid for full installed **KEENSERTS**[®].

Part-no. example:

The part-no. for metric **KEENSERTS**[®] are coded as follows:

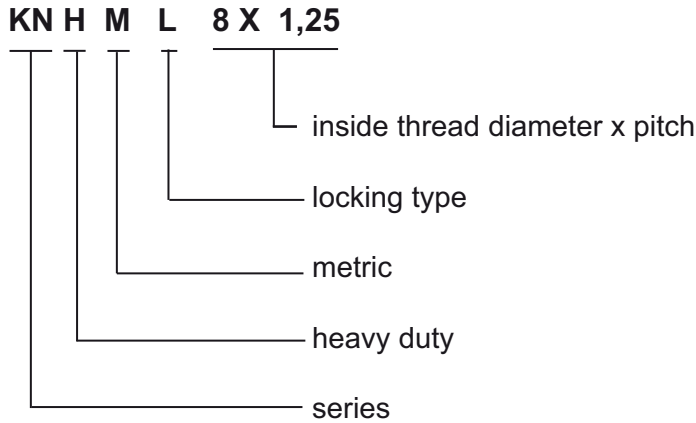

The part-no. for imperial **KEENSERTS**[®] are coded as follows:

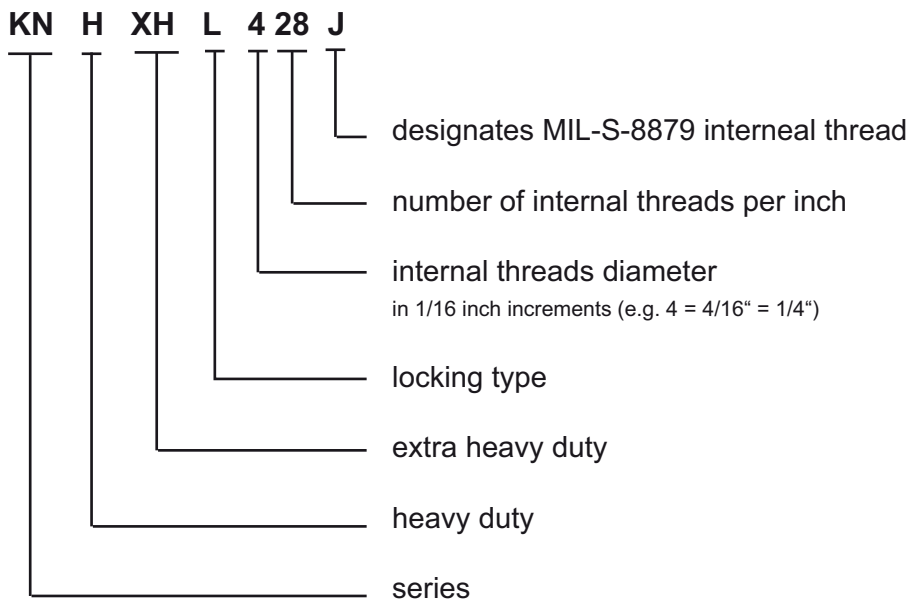

Installation:

- Drill - with standard drill
- Countersink - with cone countersink (80° - 100°)
- Thread - with standard tap
- Screw in - by hand or with installation tool
(see installation data pages B-1 to B-4)
- Lock in Place - drive the kees into place by hand
or in a press with the appropriate
installation tool

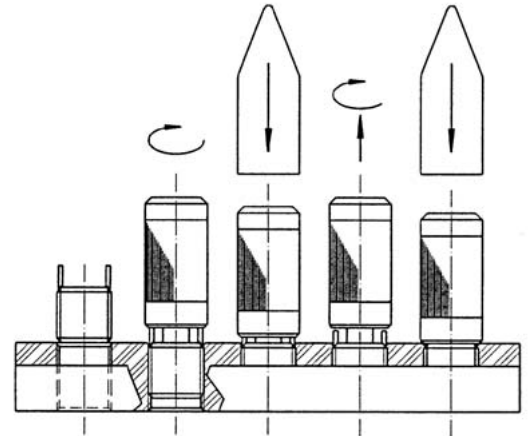

Installation depth of the **KEENSERTS**[®] is determined by the pre-assembled kees.
The installed depth of the **KEENSERTS**[®] is based on the depth of the countersink.

Installation in hard materials

For very hard materials with a hardness greater than 30 HRC or 300 Vickers it is necessary to pre-broach the slots for the kees. The first step is to mark the position of the kees on the parent material. To do this wind the **KEENSERTS**[®] in until the kees touch the surface of the parent material.

Mark the positions of the kees and unwind the **KEENSERTS**[®].

Then line up the blades of the broaching tool with the marked positions and push it in with a hammer or under a press, remove the tool and install the **KEENSERTS**[®].

In some cases it may be necessary to run the tap back down the hole to clear out any burrs. Available for external metrical thread M5 and up and external imperial thread 1/4" and up.



Removal:

1. Drilling
Dimensions see pages B1 to B4
2. Deflect kees inward and break off
3. Remove insert with E-Z out type tool
4. Insert new **KEENSERTS**[®] as before

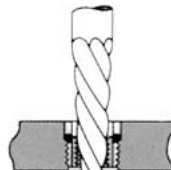
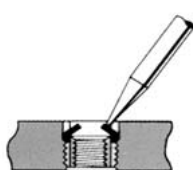
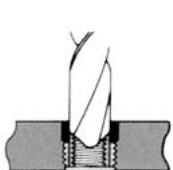

KNCM Series

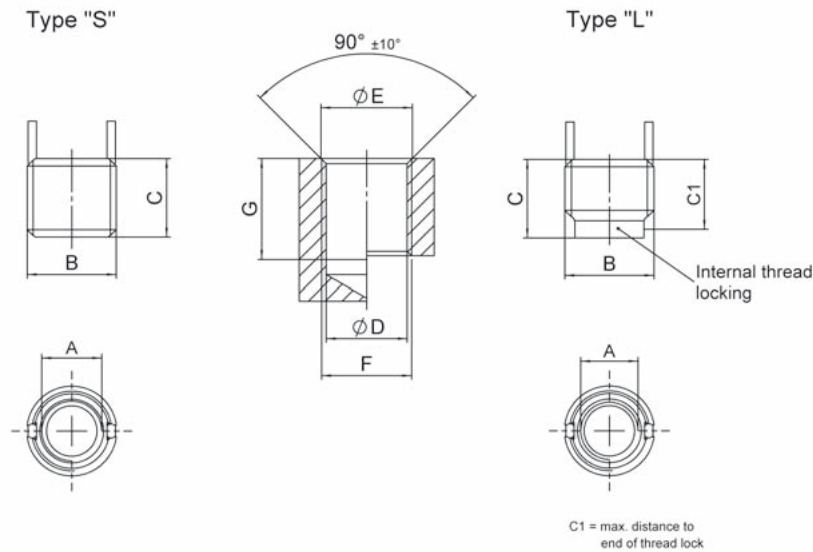

Part-no.		Dimensions				
Standard type "S"	Locking type "L"	Thread A Ø A class 5H	Thread B Ø B class 4h	Shear engagement mm ²	C ± 0,25	C1
KNCM2X0,4		M2X0,4	M4X0,7	16,5	3	2,2
	KNCML2X0,4			10,3		
KNCM2,5X0,45		M2,5X0,45	M4,5X0,75	26,5	3,8	2,7
	KNCML2,5X0,45			15,9		
KNCM3X0,5		M3X0,5	M5X0,8	33,1	4,25	3,1
	KNCML3X0,5			21,4		
KNCM4X0,7		M4X0,7	M6X0,75	58,4	5,25	4,1
	KNCML4X0,7			42,9		

Part-no.	Installation dimensions					Removal dimensions	
	Ø D modified tap drill Ø	Ø E counter- sink Ø + 0,25	Thread F		Hand installation tool part-no.	Drill	
			Ø F class 6H	G min.		Ø	Depth
KNCM2X0,4	3,4 +0,080 -0,025	4,1	M4X0,7	4,0	KRTM2-01	2,8	2,00
KNCML2X0,4							
KNCM2,5X0,45	3,9 +0,080 -0,025	4,6	M4,5X0,75	5,0	KRTM2,5-01	3,0	2,00
KNCML2,5X0,45							
KNCM3X0,5	4,4 +0,080 -0,025	5,1	M5X0,8	5,5	KRTM3-01	3,5	2,25
KNCML3X0,5							
KNCM4X0,7	5,5 +0,080 -0,025	6,1	M6X0,75	6,5	KRTM4-01	4,6	2,50
KNCML4X0,7							

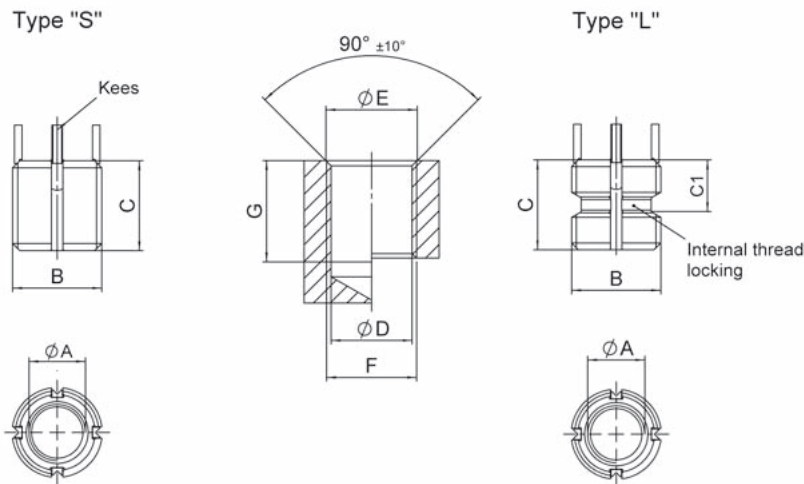

Kees:
Inserts with internal thread size of M6 and under are furnished with 2 locking kees
Inserts with internal thread size of M8 and above are furnished with 4 locking kees

C1 = max. distance to end of thread lock

KNM Series

Part-no.		Dimensions				
Standard type "S"	Locking type "L"	Thread A Ø A class 5H	Thread B Ø B class 4h	Shear engagement mm ²	C ± 0,30	C1
KNM5X0,8		M5X0,8	M8X1,25	104,9	8	7,6
	KNML5X0,8			83,1		
KNM6X1,0		M6X1,0	M10X1,25	177,7	10	8,2
	KNML6X1,0			152,7		
KNM8X1,25		M8X1,25	M12X1,25	266,7	12	9,5
	KNML8X1,25			242,7		
KNM10X1,5		M10X1,5	M14X1,5	341,6	14	10,0
	KNML10X1,5			316,4		
KNM12X1,75		M12X1,75	M16X1,5	470,2	16	11,2
	KNML12X1,75			441,4		

Part-no.	Installation dimensions				Hand installation tool part-no.	Removal dimensions	
	Ø D modified tap drill Ø	Ø E counter- sink Ø + 0,25	Thread F			Drill	
			Ø F class 6H	G min.		Ø	Depth
KNM5X0,8	6,90 +0,100 -0,025	8,25	M8X1,25	9,5	KRTM5-01	5,5	4,00
KNML5X0,8							
KNM6X1,0	8,80 +0,100 -0,025	10,25	M10X1,25	11,5	KRTM6-01	7,5	4,75
KNML6X1,0							
KNM8X1,25	10,80 +0,100 -0,025	12,25	M12X1,25	13,5	KRTM8-01	9,5	4,75
KNML8X1,25							
KNM10X1,5	12,80 +0,130 -0,025	14,25	M14X1,5	15,5	KRTM10-01	11,5	4,75
KNML10X1,5							
KNM12X1,75	14,75 +0,130 -0,025	16,25	M16X1,5	17,5	KRTM12-01	13,5	4,75
KNML12X1,75							

Type "S"

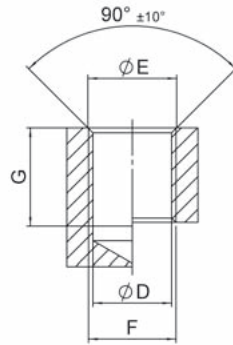
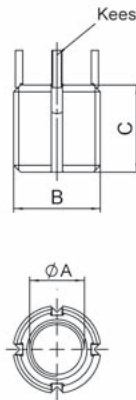

Type "L"

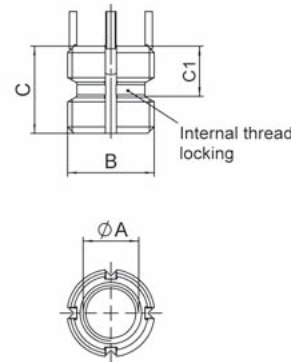

KNHM Series

Kees:
Inserts with internal thread size of M6 and under are furnished with 2 locking kees
Inserts with internal thread size of M8 and above are furnished with 4 locking kees

C1 = max. distance to end of thread lock

Part-no.		Dimensions				
Standard type "S"	Locking type "L"	Thread A Ø A class 5H	Thread B Ø B class 4h	Shear engagement mm ²	C ± 0,30	C1
KNHM4X0,7		M4X0,7	M8X1,25	104,9	8	
	KNHML4X0,7			83,1		8,0
KNHM5X0,8		M5X0,8	M10X1,25	177,1	10	
	KNHML5X0,8			152,7		8,7
KNHM6X1,0		M6X1,0	M12X1,25	266,7	12	
	KNHML6X1,0			242,5		9,5
KNHM8X1,25		M8X1,25	M14X1,5	341,6	14	
	KNHML8X1,25			316,4		10,0
KNHM10X1,5		M10X1,5	M16X1,5	470,2	16	
	KNHML10X1,5			441,4		10,0
KNHM12X1,75		M12X1,75	M18X1,5	608,5	18	
	KNHML12X1,75			561,8		10,7

Part-no.	Installation dimensions				Hand installation tool part-no.	Removal dimensions	
	Ø D modified tap drill Ø	Ø E counter-sink Ø + 0,25	Thread F			Drill	
			Ø F class 6H	G min.		Ø	Depth
KNHM4X0,7	6,90 ^{+0,100} _{-0,025}	8,25	M8X1,25	9,5	KRTM4-02	5,5	4,00
KNHML4X0,7							
KNHM5X0,8	8,80 ^{+0,100} _{-0,025}	10,25	M10X1,25	12,5	KRTM5-02	7,5	4,75
KNHML5X0,8							
KNHM6X1,0	10,80 ^{+0,100} _{-0,025}	12,25	M12X1,25	14,5	KRTM6-02	9,5	4,75
KNHML6X1,0							
KNHM8X1,25	12,80 ^{+0,130} _{-0,025}	14,25	M14X1,5	16,5	KRTM8-02	11,5	4,75
KNHML8X1,25							
KNHM10X1,5	14,75 ^{+0,130} _{-0,025}	16,25	M16X1,5	18,5	KRTM10-02	13,5	4,75
KNHML10X1,5							
KNHM12X1,75	16,75 ^{+0,130} _{-0,025}	18,25	M18X1,5	20,5	KRTM12-02	15,5	4,75
KNHML12X1,75							

KNHM Series

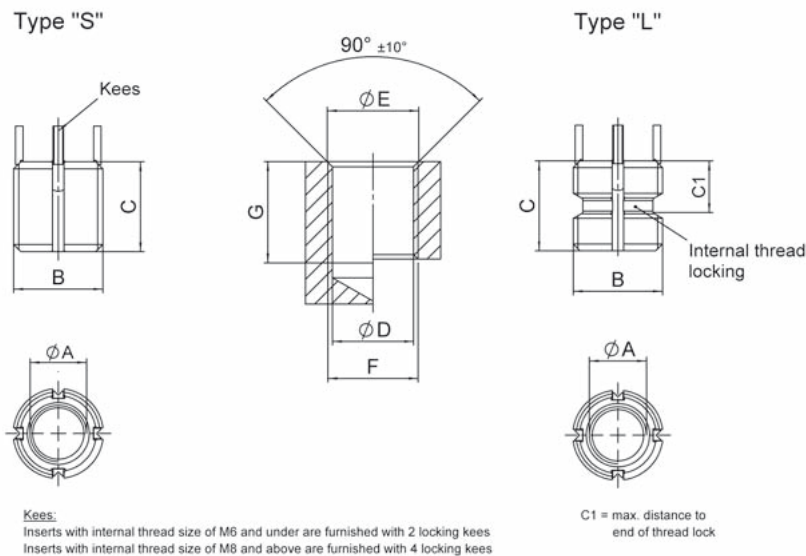

Part-no.		Dimensions				
Standard type "S"	Locking type "L"	Thread A Ø A class 5H	Thread B Ø B class 4h	Shear engagement mm ²	C ± 0,30	C1
KNHM14X2,0		M14X2,0	M20X1,5	770,5	20	12,4
	KNHML14X2,0			724,4		
KNHM16X2,0		M16X2,0	M22X1,5	896,8	22	12,4
	KNHML16X2,0			855,2		
KNHM18X1,5		M18X1,5	M24X1,5	1084,4	24	16,8
	KNHML18X1,5			1051,5		
KNHM20X2,5		M20X2,5	M30X2,0	1774,3	30	17,5
	KNHML20X2,5			1736,4		
KNHM24X3,0		M24X3,0	M33X2,0	2189,4	33	19,0
	KNHML24X3,0			2161,9		

Part-no.	Installation dimensions					Removal dimensions	
	Ø D modified tap drill Ø	Ø E counter- sink Ø + 0,25	Thread F		Hand installation tool part-no.	Drill	
			Ø F class 6H	G min.		Ø	Depth
KNHM14X2,0	18,75 +0,130 -0,025	20,25	M20X1,5	22,5	KRTM14-02	17,50	4,75
KNHML14X2,0							
KNHM16X2,0	20,50 +0,130 -0,025	22,25	M22X1,5	24,5	KRTM16-02	17,75	6,35
KNHML16X2,0							
KNHM18X1,5	22,50 +0,130 -0,025	24,25	M24X1,5	26,5	KRTM18-02	19,75	6,35
KNHML18X1,5							
KNHM20X2,5	28,00 +0,130 -0,025	30,25	M30X2,0	34,5	KRTM20-02	25,75	6,35
KNHML20X2,5							
KNHM24X3,0	31,00 +0,130 -0,025	33,25	M33X2,0	37,5	THM24	28,75	6,35
KNHML24X3,0							

KNCA Series

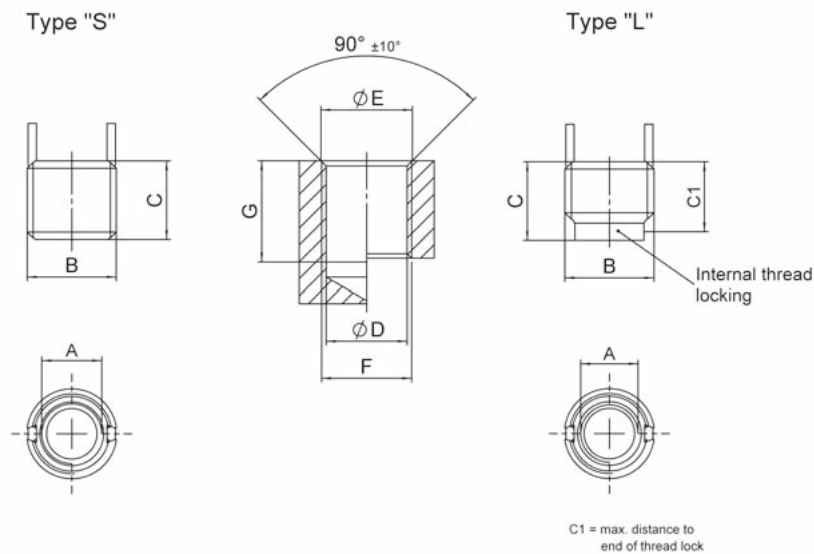

Part-no.		Dimensions				
Standard type "S"	Locking type "L"	Thread A Ø A	Thread B Ø B	Shear engagement inch ² (mm ²)	C inch (mm)	C1 inch (mm)
KNCA0256J		2-56" UNCJ-3B	8-32" UNC-3A	0,0157 (10,1)	0,12 (3,05)	0,088 (2,24)
KNCA0440J		4-40" UNCJ-3B	10-32" UNF-2A	0,0302 (19,5)	0,17 (4,32)	0,125 (3,18)
	KNCAL0440J			0,0302 (19,5)		
KNC0632J		6-32" UNCJ-3B	12-28" UNF-2A	0,0329 (21,2)	0,17 (4,32)	0,125 (3,18)
	KNCL0632J			0,0329 (21,2)		
KNCA0832J		8-32" UNCJ-3B	1/4-28" UNF-2A	0,0669 (43,2)	0,22 (5,59)	0,175 (4,45)
	KNCAL0832J			0,0669 (43,2)		

Part-no.	Installation dimensions				Hand installation tool part-no.	Removal dimensions	
	Ø D modified tap drill Ø inch	Ø E counter- sink Ø inch	Thread F			Drill	
			Ø F	G min. inch (mm)		Ø inch (mm)	Depth inch (mm)
KNCA0256J	.134 ^{+0,003} -0,001	.166 ^{+0,001} -0,000	8-32 UNC-2B	0,140 (3,56)	TKNC02	0,133 (2,87)	1/16 (1,59)
KNCA0440J	.161 ^{+0,003} -0,001	.194 ^{+0,001} -0,000	10-32 UNF-2B	0,160 (4,06)	TKNC04	0,136 (3,45)	3/32 (2,38)
KNCA0440J							
KNC0632J	.187 ^{+0,003} -0,001	.220 ^{+0,001} -0,000	12-28 UNF-2B	0,160 (4,06)	TKNC06	0,159 (4,04)	3/32 (2,38)
KNCL0632J							
KNCA0832J	.228 ^{+0,003} -0,001	.225 ^{+0,001} -0,000	1/4-28 UNF-2B	0,210 (5,33)	TKNC08	0,199 (5,05)	1/8 (3,18)
KNCAL0832J							

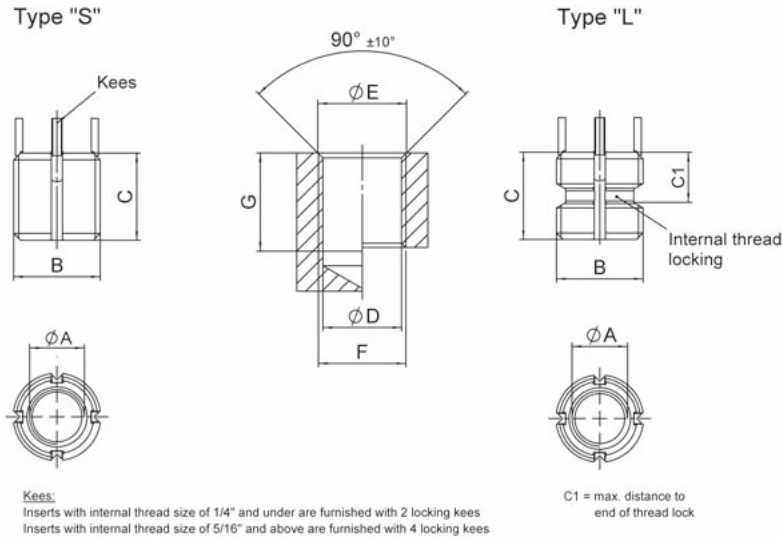

KNJ Series

Part-no.		Dimensions				
Standard type "S"	Locking type "L"	Thread A Ø A class 3B	Thread B Ø B class 2A mod.	Shear engagement inch ² (mm ²)	C inch (mm)	C1 inch (mm)
KN1032J	KNL1032J	10-32	5/16-18	0,1517 (97,9)	0,31 (7,87)	0,31 (7,87)
				0,0945 (60,9)		
KN1024J	KNL1024J	10-24	5/16-18	0,1517 (97,9)	0,31 (7,87)	0,31 (7,87)
				0,0945 (61,0)		
KN428J	KNL428J	1/4-28	3/8-16	0,2371 (153,0)	0,37 (9,40)	0,33 (8,38)
				0,1726 (111,4)		
KN420J	KNL420J	1/4-20	3/8-16	0,2371 (153,0)	0,37 (9,40)	0,36 (9,14)
				0,1726 (111,4)		
KN524J	KNL524J	5/16-24	7/16-14	0,3049 (196,7)	0,43 (10,9)	0,34 (8,64)
				0,2321 (149,7)		
KN518J	KNL518J	5/16-18	7/16-14	0,3049 (196,7)	0,43 (10,9)	0,37 (9,40)
				0,2321 (149,7)		

Part-no.	Installation dimensions				Hand installation tool part-no.	Removal dimensions	
	Ø D modified tap drill Ø inch	Ø E countersink Ø inch +0,01 (mm)	Thread F			Drill	
			Ø F class 2B	G min. inch (mm)		Ø inch (mm)	Depth inch (mm)
KN1032J	0,272 (6,91)	0,323 (8,20)	5/16-18	0,37 (9,4)	TD1032L	7/32 (5,56)	5/32 (3,97)
KNL1032J							
KN1024J	0,272 (6,91)	0,323 (8,20)	5/16-18	0,37 (9,4)	TD1024L	7/32 (5,56)	5/32 (3,97)
KNL1024J							
KN428J	0,332 (8,43)	0,385 (9,78)	3/8-16	0,43 (10,9)	TD428L	9/32 (7,14)	3/16 (4,76)
KNL428J							
KN420J	0,332 (8,43)	0,385 (9,78)	3/8-16	0,43 (10,9)	TD420L	9/32 (7,14)	3/16 (4,76)
KNL420J							
KN524J	0,397 (10,08)	0,447 (11,35)	7/16-14	0,50 (12,7)	TD524L	11/32 (8,73)	3/16 (4,76)
KNL524J							
KN518J	0,397 (10,08)	0,447 (11,35)	7/16-14	0,50 (12,7)	TD518L	11/32 (8,73)	3/16 (4,76)
KNL518J							

Type "S"

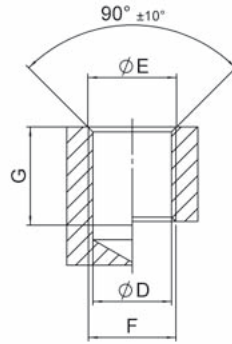
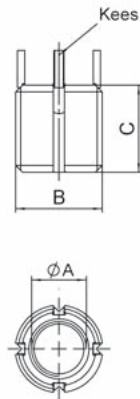

Type "L"

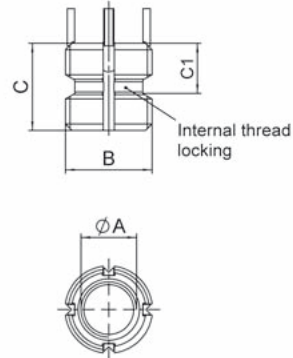

KNJ Series

Kees:
Inserts with internal thread size of 1/4" and under are furnished with 2 locking kees
Inserts with internal thread size of 5/16" and above are furnished with 4 locking kees

C1 = max. distance to end of thread lock

Part-no.		Dimensions				
Standard type "S"	Locking type "L"	Thread A Ø A class 3B	Thread B Ø B class 2A mod.	Shear engagement inch ² (mm ²)	C inch (mm)	C1 inch (mm)
KN624J	KNL624J	3/8-24	1/2-13	0,4299 (277,4)	0,50 (12,7)	0,36 (9,14)
				0,3366 (217,2)		
KN616J	KNL616J	3/8-16	1/2-13	0,4299 (277,4)	0,50 (12,7)	0,40 (10,16)
				0,3366 (217,2)		
KN720J	KNL720J	7/16-20	9/16-12	0,5665 (365,5)	0,56 (14,2)	0,41 (10,41)
				0,4606 (297,2)		
KN714J	KNL714J	7/16-14	9/16-12	0,5665 (365,5)	0,56 (14,2)	0,45 (11,43)
				0,4606 (297,2)		
KN820J	KNL820J	1/2-20	5/8-11	0,7175 (462,9)	0,62 (15,6)	0,42 (10,67)
				0,5906 (381,0)		
KN813J	KNL813J	1/2-13	5/8-11	0,7175 (462,9)	0,62 (15,6)	0,47 (11,94)
				0,5906 (381,0)		

Part-no.	Installation dimensions				Hand installation tool part-no.	Removal dimensions	
	Ø D modified tap drill Ø inch	Ø E countersink Ø inch +0,01 (mm)	Thread F			Drill	
			Ø F class 2B	G min. inch (mm)		Ø inch (mm)	Depth inch (mm)
KN624J	0,453 (11,51)	0,510 (12,95)	1/2-13	0,56 (14,2)	TD624L	13/32 (10,32)	3/16 (4,76)
KNL624J							
KN616J	0,453 (11,51)	0,510 (12,95)	1/2-13	0,56 (14,2)	TD616L	13/32 (10,32)	3/16 (4,76)
KNL616J							
KN720J	0,516 (13,11)	0,572 (14,53)	9/16-12	0,62 (15,7)	TD720-L	15/32 (11,91)	3/16 (4,76)
KNL720J							
KN714J	0,516 (13,11)	0,572 (14,53)	9/16-12	0,62 (15,7)	TD714L	15/32 (11,91)	3/16 (4,76)
KNL714J							
KN820J	0,578 (14,68)	0,635 (16,13)	5/8-11	0,68 (17,3)	TD820L	17/32 (13,49)	3/16 (4,76)
KNL820J							
KN813J	0,578 (14,68)	0,635 (16,13)	5/8-11	0,68 (17,3)	TD813L	17/32 (13,49)	3/16 (4,76)
KNL813J							

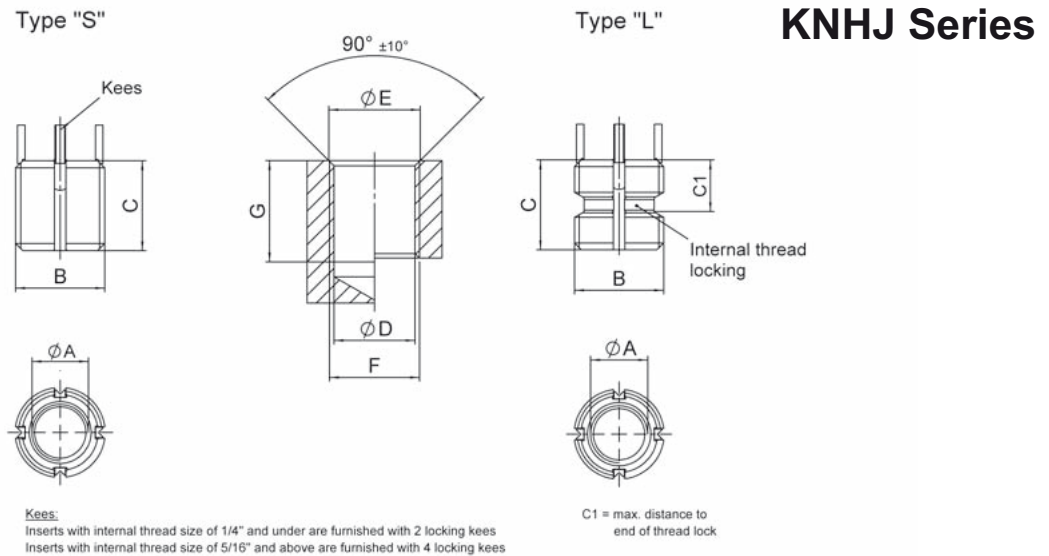

Part-no.		Dimensions				
Standard type "S"	Locking type "L"	Thread A Ø A class 3B	Thread B Ø B class 2A mod.	Shear engagement inch ² (mm ²)	C inch (mm)	C1 inch (mm)
KNH1032J	KNHL1032J	10-32	3/8-16	0,1901 (122,7)	0,31 (7,87)	0,31 (7,87)
				0,1156 (74,6)		
KNH1024J	KNHL1024J	10-24	3/8-16	0,1901 (122,7)	0,31 (7,87)	0,31 (7,87)
				0,1156 (74,6)		
KNH428J	KNHL428J	1/4-28	7/16-14	0,2842 (183,4)	0,37 (9,40)	0,33 (8,38)
				0,1970 (127,1)		
KNH420J	KNHL420J	1/4-20	7/16-14	0,2842 (183,4)	0,37 (9,40)	0,33 (8,38)
				0,1970 (127,1)		
KNH524J	KNHL524J	5/16-24	1/2-13	0,3588 (231,5)	0,43 (10,9)	0,34 (8,64)
				0,2608 (168,3)		

Part-no.	Installation dimensions					Removal dimensions	
	Ø D modified tap drill Ø inch	Ø E countersink Ø inch +0,01 (mm)	Thread F		Hand installation tool part-no.	Drill	
			Ø F class UNC-2B	G min. inch (mm)		Ø inch (mm)	Depth inch (mm)
KNH1032J	0,332 (8,43)	0,385 (9,78)	3/8-16	0,37 (9,4)	THD1032L	9/32 (7,14)	1/8 (3,18)
KNHL1032J							
KNH1024J	0,332 (8,43)	0,385 (9,78)	3/8-16	0,37 (9,4)	THD1024L	9/32 (7,14)	1/8 (3,18)
KNHL1024J							
KNH428J	0,397 (10,08)	0,447 (11,35)	7/16-14	0,43 (10,9)	THD428L	11/32 (8,73)	3/16 (4,76)
KNHL428J							
KNH420J	0,397 (10,08)	0,447 (11,35)	7/16-14	0,43 (10,9)	THD420L	11/32 (8,73)	3/16 (4,76)
KNHL420J							
KNH524L	0,453 (11,51)	0,510 (12,95)	1/2-13	0,50 (12,7)	THD524L	13/32 (10,32)	3/16 (4,76)
KNHL524L							

Type "S"

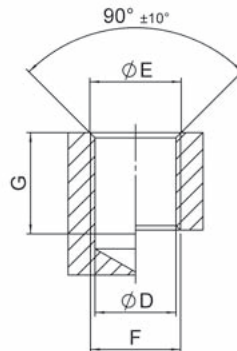
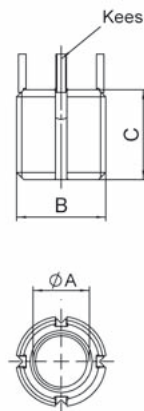

Type "L"

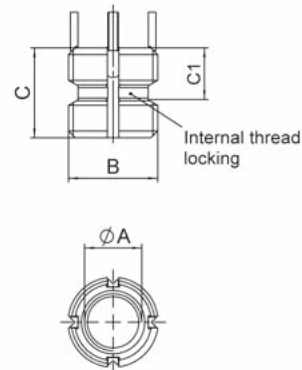

Kees:
Inserts with internal thread size of 1/4" and under are furnished with 2 locking kees
Inserts with internal thread size of 5/16" and above are furnished with 4 locking kees

C1 = max. distance to end of thread lock

KNHJ Series

Part-no.		Dimensions				
Standard type "S"	Locking type "L"	Thread A Ø A class 3B	Thread B Ø B class 2A mod.	Shear engagement inch ² (mm ²)	C inch (mm)	C1 inch (mm)
KNH518J	KNHL518J	5/16-18	1/2-13	0,3588 (231,5)	0,43 (10,9)	0,37 (9,40)
				0,2608 (168,3)		
KNH624J	KNHL624J	3/8-24	9/16-12	0,4975 (321,0)	0,50 (12,7)	0,37 (9,40)
				0,3843 (248,0)		
KNH616J	KNHL616J	3/8-16	9/16-12	0,4975 (321,0)	0,50 (12,7)	0,41 (10,41)
				0,3843 (248,0)		
KNH720J	KNHL720J	7/16-20	5/8-11	0,7172 (462,7)	0,62 (15,8)	0,42 (10,67)
				0,5831 (376,2)		
KNH714J	KNHL714J	7/16-14	5/8-11	0,7172 (462,7)	0,62 (15,8)	0,46 (11,68)
				0,5831 (376,2)		

Part-no.	Installation dimensions					Removal dimensions	
	Ø D modified tap drill Ø inch	Ø E countersink Ø inch +0,01 (mm)	Thread F		Hand installation tool part-no.	Drill	
			Ø F class UNC-2B	G min. inch (mm)		Ø inch (mm)	Depth inch (mm)
KNH518J	0,453 (11,51)	0,510 (12,95)	1/2-13	0,50 (12,7)	THD518L	13/32 (10,32)	3/16 (4,76)
KNHL518J							
KNH624J	0,516 (13,11)	0,572 (14,53)	9/16-12	0,56 (14,2)	THD624L	15/32 (11,91)	3/16 (4,76)
KNHL624J							
KNH616J	0,516 (13,11)	0,572 (14,53)	9/16-12	0,56 (14,2)	THD616L	15/32 (11,91)	3/16 (4,76)
KNHL616J							
KNH720J	0,578 (14,68)	0,635 (16,13)	5/8-11	0,68 (17,27)	THD720L	17/32 (13,49)	3/16 (4,76)
KNHL720J							
KNH714L	0,578 (14,68)	0,635 (16,13)	5/8-11	0,68 (17,27)	THD714L	17/32 (13,49)	3/16 (4,76)
KNHL714L							

Type "S"

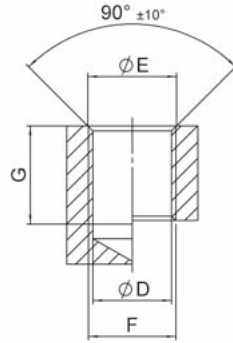
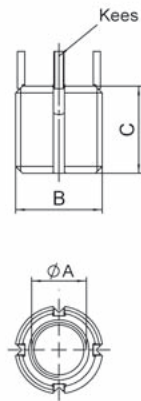

Type "L"

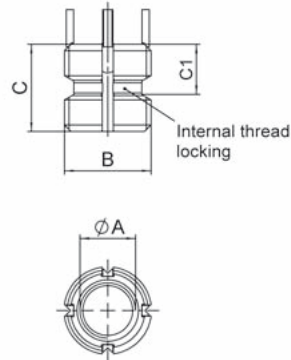

KNHJ Series

Kees:
Inserts with internal thread size of 1/4" and under are furnished with 2 locking kees
Inserts with internal thread size of 5/16" and above are furnished with 4 locking kees

C1 = max. distance to end of thread locking

Part-no.		Dimensions				
Standard type "S"	Locking type "L"	Thread A Ø A class 3B	Thread B Ø B class 2A mod.	Shear engagement inch ² (mm ²)	C inch (mm)	C1 inch (mm)
KNH820J	KNHL820J	1/2-20	11/16-11NS	0,8884 (573,2)	0,68 (17,3)	0,42 (10,67)
				0,7368 (475,4)		
KNH813J	KNHL813J	1/2-13	11/16-11NS	0,8884 (573,2)	0,68 (17,3)	0,47 (11,94)
				0,7368 (475,4)		
KNH918J	KNHL918J	9/16-18	13/16-16	1,2493 (806,0)	0,81 (20,6)	0,48 (12,19)
				1,0247 (661,1)		
KNH912J	KNHL912J	9/16-12	13/16-16	1,2493 (806,0)	0,81 (20,6)	0,54 (13,72)
				1,0247 (661,1)		
KNH1018J	KNHL1018J	5/8-18	7/8-14	1,4866 (959,1)	0,87 (22,1)	0,49 (12,47)
				1,2415 (801,0)		
KNH1011J	KNHL1011J	5/8-11	7/8-14	1,4866 (959,1)	0,87 (22,1)	0,57 (14,48)
				1,2415 (801,0)		

Part-no.	Installation dimensions					Removal dimensions	
	Ø D modified tap drill Ø inch	Ø E countersink Ø inch +0,01 (mm)	Thread F		Hand installation tool part-no.	Drill	
			Ø F class UNC-2B	G min. inch (mm)		Ø inch (mm)	Depth inch (mm)
KNH820J	0,641 (16,28)	0,700 (17,80)	11/16-11NS	0,75 (19,06)	THD820L	19/32 (15,08)	3/16 (4,76)
KNHL820J							
KNH813J	0,641 (16,28)	0,700 (17,80)	11/16-11NS	0,75 (19,06)	THD813L	19/32 (15,08)	3/16 (4,76)
KNHL813J							
KNH918J	0,766 (19,46)	0,822 (20,88)	13/16-16UN	0,94 (23,88)	THD918L	23/32 (18,26)	3/16 (4,76)
KNHL918J							
KNH912J	0,766 (19,46)	0,822 (20,88)	13/16-16UN	0,94 (23,88)	THD912L	23/32 (18,26)	3/16 (4,76)
KNHL912J							
KNH1018L	0,828 (21,03)	0,885 (22,48)	7/8-14UNF	1,00 (25,40)	THD1018L	25/32 (19,84)	3/16 (4,76)
KNHL1018L							
KNH1011J	0,828 (21,03)	0,885 (22,48)	7/8-14 UNF	1,00 (25,40)	THD1011L	25/32 (19,84)	3/16 (4,76)
KNHL1011J							

Type "S"

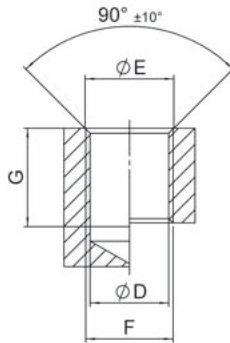
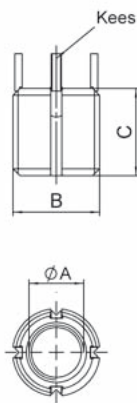

Type "L"

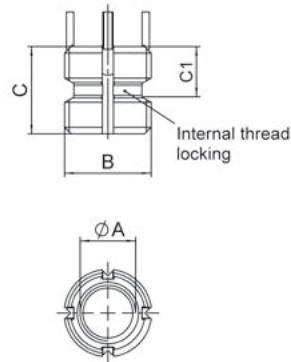

KNHJ Series

Kees:
Inserts with internal thread size of 1/4" and under are furnished with 2 locking kees
Inserts with internal thread size of 5/16" and above are furnished with 4 locking kees

C1 = max. distance to end of thread lock

Part-no.		Dimensions				
Standard type "S"	Locking type "L"	Thread A Ø A class 3B	Thread B Ø B class 2A mod.	Shear engagement inch ² (mm ²)	C inch (mm)	C1 inch (mm)
KNH1216J		3/4-16	1-1/8-12	2,4901 (1606,5)	1,12 (28,5)	
	KNHL1216J			2,4478 (1579,3)	1,25 (31,8)	0,68 (17,27)
KNH1210J		3/4-10	1-1/8-12	2,4901 (1606,5)	1,12 (28,5)	
	KNHL1210J			2,4478 (1579,3)	1,25 (31,8)	0,75 (19,05)
KNH1414J		7/8-14	1-1/4-12	3,1370 (2024,1)	1,25 (31,8)	
	KNHL1414J			3,0775 (1985,6)	1,37 (34,8)	0,69 (17,53)
KNH1409J		7/8-9	1-14/12	3,1370 (2024,1)	1,25 (31,8)	
	KNHL1409J			3,0775 (1985,6)	1,37 (34,8)	0,77 (19,56)
KNH1612J		1-12	1-3/8-12	3,8381 (2476,3)	1,37 (34,8)	
	KNHL1612J			3,7929 (2447,2)	1,50 (38,1)	0,78 (19,81)
KNH1608J		1-8	1-3/8-12	3,8381 (2476,3)	1,37 (34,8)	
	KNHL1608J			3,7929 (2447,2)	1,50 (38,1)	0,86 (21,84)

Part-no.	Installation dimensions					Removal dimensions	
	Ø D modified tap drill Ø inch	Ø E countersink Ø inch +0,01 (mm)	Thread F		Hand installation tool part-no.	Drill	
			Ø F class UNC- 2B	G min. inch (mm)		Ø inch (mm)	Depth inch (mm)
KNH1216J	1,062 (26,97)	1,145 (29,08)	1-1/8-12 UNF	1,31 (33,27)	THD1216L	31/32 (24,61)	5/16 (7,94)
KNHL1216J				1,44 (36,58)			
KNH1210J	1,062 (26,97)	1,145 (29,08)	1-1/8-12 UNF	1,31 (33,27)	THD1210L	31/32 (24,61)	5/16 (7,94)
KNHL1210J				1,44 (36,58)			
KNH1414J	1,187 (30,15)	1,270 (32,26)	1-1/4-12 UNF	1,44 (36,58)	THD1414L	1-3/32 (27,78)	5/16 (7,94)
KNHL1414J				1,56 (39,62)			
KNH1409L	1,187 (30,15)	1,270 (32,26)	1-1/4-12 UNF	1,44 (36,58)	THD1409L	1-3/32 (27,78)	5/16 (7,94)
KNHL1409L				1,56 (39,62)			
KNH1612J	1,312 (33,32)	1,395 (35,43)	1-3/8-12 UNF	1,56 (39,62)	THD1612L	1-7/32 (30,96)	5/16 (7,94)
KNHL1612J				1,68 (42,67)			
KNH1608J	1,312 (33,32)	1,395 (35,43)	1-3/8-12 UNF	1,56 (39,62)	THD1608L	1-7/32 (30,96)	5/16 (7,94)
KNHL1608J				1,68 (42,67)			

Type "S"

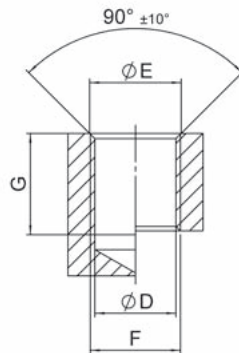
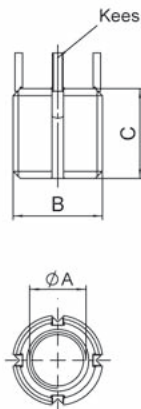

Type "L"

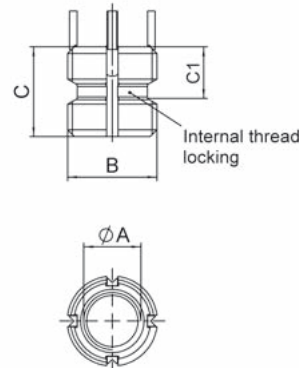

KNHXHJ Series

Kees:

Inserts with internal thread size of 10-24", 10-32" and under are furnished with 2 locking kees
Inserts with internal thread size of 1/4" and above are furnished with 4 locking kees

C1 = max. distance to end of thread lock

Part-no.		Dimensions				
Standard type "S"	Locking type "L"	Thread A Ø A class 3B	Thread B Ø B class 2A mod.	Shear engagement inch ² (mm ²)	C inch (mm)	C1 inch (mm)
KNHXH1032J		10-32	7/16-14	0,2299 (148,3)	0,31 (7,9)	0,31 (7,90)
	KNHXHL1032J			0,1403 (90,5)		
KNHXH1024J		10-24	7/16-14	0,2299 (148,3)	0,31 (7,9)	0,31 (7,90)
	KNHXHL1024J			0,1403 (90,5)		
KNHXH428J		1/4-28	1/2-13	0,2997 (193,4)	0,37 (9,4)	0,33 (8,38)
	KNHXHL428J			0,2005 (129,4)		
KNHXH420J		1/4-20	1/2-13	0,2997 (193,4)	0,37 (9,4)	0,36 (9,14)
	KNHXHL420J			0,2005 (129,4)		
KNHXH524J		5/16-24	9/16-12	0,4163 (268,6)	0,43 (10,9)	0,34 (8,64)
	KNHXHL524J			0,3029 (195,4)		

Part-no.	Installation dimensions					Removal dimensions	
	Ø D modified tap drill Ø inch	Ø E countersink Ø inch +0,01 (mm)	Thread F		Hand installation tool part-no.	Drill	
			Ø F class UNC- 2B	G min. inch (mm)		Ø inch (mm)	Depth inch (mm)
KNHXH1032J	0,397 (10,08)	0,447 (11,35)	7/16-14	0,37 (9,40)	THXHD1032L	11/32 (8,73)	3/16 (4,76)
KNHXHL1032J							
KNHXH1024J	0,397 (10,08)	0,447 (11,35)	7/16-14	0,37 (9,40)	THXHD1024L	11/32 (8,73)	3/16 (4,76)
KNHXHL1024J							
KNHXH428J	0,453 (11,51)	0,510 (12,95)	1/2-13	0,44 (11,18)	THXHD428L	13/32 (10,32)	3/16 (4,76)
KNHXHL428J							
KNHXH420J	0,453 (11,51)	0,510 (12,95)	1/2-13	0,44 (11,18)	THXHD420L	13/32 (10,32)	3/16 (4,76)
KNHXHL420J							
KNHXH524J	0,516 (13,11)	0,572 (14,53)	9/16-12	0,50 (12,70)	THXHD524L	15/32 (11,91)	3/16 (4,76)
KNHXHL524J							

Type "S"

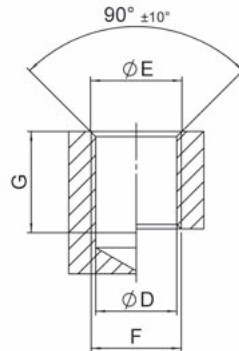
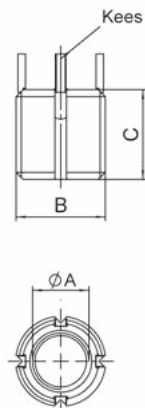

Type "L"

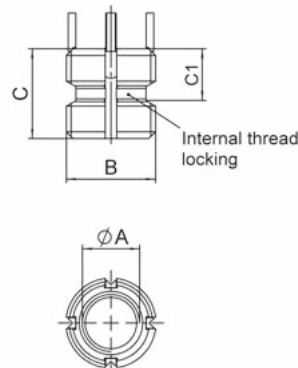

KNHXHJ Series

Kees:
Inserts with internal thread size of 10-24", 10-32" and under are furnished with 2 locking kees
Inserts with internal thread size of 1/4" and above are furnished with 4 locking kees

C1 = max. distance to end of thread lock

Part-no.		Dimensions				
Standard type "S"	Locking type "L"	Thread A Ø A class 3B	Thread B Ø B class 2A mod.	Shear engagement inch ² (mm ²)	C inch (mm)	C1 inch (mm)
KNHXH518J		5/16-18	9/16-12	0,4163 (268,6)	0,43 (10,9)	
	KNHXHL518J			0,3029 (195,4)		0,37 (9,40)
KNHXH624J		3/8-24	5/8-11	0,5584 (360,3)	0,50 (12,7)	
	KNHXHL624J			0,4234 (273,8)		0,37 (9,40)
KNHXH616J		3/8-16	5/8-11	0,5584 (360,3)	0,50 (12,7)	
	KNHXHL616J			0,4234 (273,8)		0,41 (10,41)
KNHXH720J		7/16-20	11/16-11 NS	0,8000 (516,1)	0,62 (15,6)	
	KNHXHL720J			0,6498 (419,2)		0,42 (10,67)
KNHXH714J		7/16-14	11/16-11 NS	0,8000 (516,1)	0,62 (15,6)	
	KNHXHL714J			0,6498 (419,2)		0,46 (11,68)

Part-no.	Installation dimensions				Hand installation tool part-no.	Removal dimensions	
	Ø D modified tap drill Ø inch	Ø E countersink Ø inch +0,01 (mm)	Thread F			Drill	
			Ø F class UNC- 2B	G min. inch (mm)		Ø inch (mm)	Depth inch (mm)
KNHXH518J	0,516 (13,11)	0,572 (14,53)	9/16-12	0,50 (12,70)	THXHD518L	15/32 (11,91)	3/16 (4,76)
KNHXHL518J							
KNHXH624J	0,578 (14,68)	0,635 (16,13)	5/8-11	0,56 (14,22)	THXHD624L	17/32 (13,49)	3/16 (4,76)
KNHXHL624J							
KNHXH616J	0,578 (14,68)	0,635 (16,13)	5/8-11	0,56 (14,22)	THXHD616L	17/32 (13,49)	3/16 (4,76)
KNHXHL616J							
KNHXH720J	0,641 (16,28)	0,700 (17,80)	11/16-11 NS	0,68 (17,27)	THXHD720L	19/32 (15,08)	3/16 (4,76)
KNHXHL720J							
KNHXH714J	0,641 (16,28)	0,700 (17,80)	11/16-11 NS	0,68 (17,27)	THXHD714L	19/32 (15,08)	3/16 (4,76)
KNHXHL714J							

Type "S"

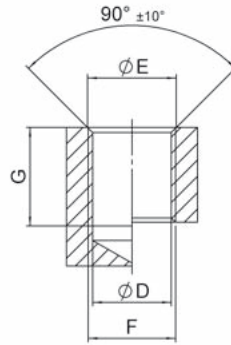
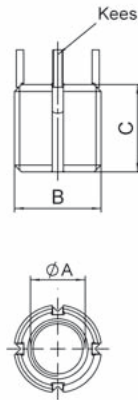

Type "L"

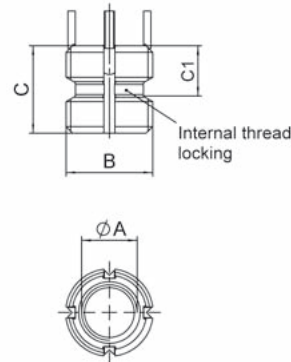

KNHXHJ Series

Kees:
Inserts with internal thread size of 10-24", 10-32" and under are furnished with 2 locking kees
Inserts with internal thread size of 1/4" and above are furnished with 4 locking kees

C1 = max. distance to end of thread lock

Part-no.		Dimensions				
Standard type "S"	Locking type "L"	Thread A Ø A class 3B	Thread B Ø B class 2A mod.	Shear engagement inch ² (mm ²)	C inch (mm)	C1 inch (mm)
KNHXH820J		1/2-20	13/16-16	1,0293 (664,1)	0,68 (17,3)	0,42 (10,67)
	KNHXHL820J			0,8642 (557,6)		
KNHXH813J		1/2-13	13/16-16	1,0293 (664,1)	0,68 (17,3)	0,47 (11,94)
	KNHXHL813J			0,8642 (557,6)		
KNHXH918J		9/16-18	7/8-14	1,3761 (887,8)	0,81 (20,6)	0,48 (12,19)
	KNHXHL918J			1,1131 (718,1)		
KNHXH912J		9/16-12	7/8-14	1,3761 (887,8)	0,81 (20,6)	0,54 (13,72)
	KNHXHL912J			1,1131 (718,1)		
KNHXH1018J		5/8-18	1-12	1,6420 (1059,4)	0,87 (22,1)	0,51 (12,95)
	KNHXHL1018J			1,2770 (823,9)		
KNHXH1011J		5/8-11	1-12	1,6420 (1059,4)	0,87 (22,1)	0,59 (14,99)
	KNHXHL1011J			1,2770 (823,9)		

Part-no.	Installation dimensions				Hand installation tool part-no.	Removal dimensions	
	Ø D modified tap drill Ø inch	Ø E countersink Ø inch +0,01 (mm)	Thread F			Drill	
			Ø F class UNC-2B	G min. inch (mm)		Ø inch (mm)	Depth inch (mm)
KNHXH820J	0,766 (19,46)	0,822 (20,88)	13/16-16 UNF	0,75 (19,05)	THXHD820L	23/32 (18,26)	3/16 (4,76)
KNHXHL820J							
KNHXH813J	0,766 (19,46)	0,822 (20,88)	13/16-16 UNF	0,75 (19,05)	THXHD813L	23/32 (18,26)	3/16 (4,76)
KNHXHL813J							
KNHXH918J	0,828 (21,03)	0,885 (22,48)	7/8-14 UNF	0,94 (23,88)	THXHD918L	25/32 (19,84)	3/16 (4,76)
KNHXHL918J							
KNHXH912J	0,828 (21,03)	0,885 (22,48)	7/8-14 UNF	0,94 (23,88)	THXHD912L	25/32 (19,84)	3/16 (4,76)
KNHXHL912J							
KNHXH1018J	0,937 (23,80)	1,020 (25,91)	1-12 UNF	1,00 (25,40)	THXHD1018L	27/32 (21,43)	5/16 (7,94)
KNHXHL1018J							
KNHXH1011J	0,937 (23,80)	1,020 (25,91)	1-12 UNF	1,00 (25,40)	THXHD1011L	27/32 (21,43)	5/16 (7,94)
KNHXHL1011J							

Type "S"

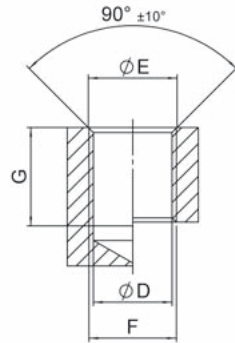
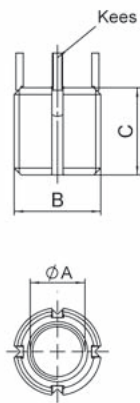

Type "L"

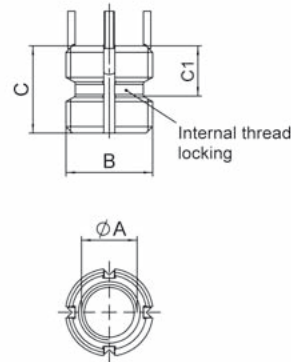

KNHXHJ Series

Kees:
Inserts with internal thread size of 10-24", 10-32" and under are furnished with 2 locking kees
Inserts with internal thread size of 1/4" and above are furnished with 4 locking kees

C1 = max. distance to end of thread lock

Part-no.		Dimensions				
Standard type "S"	Locking type "L"	Thread A Ø A class 3B	Thread B Ø B class 2A mod.	Shear engagement inch ² (mm ²)	C inch (mm)	C1 inch (mm)
KNHXH1216J		3/4-16	1-1/4-12	2,7966 (1804,2)	1,12 (28,5)	
	KNHXHL1216J			2,5505 (1645,5)	1,25 (31,8)	0,57 (14,48)
KNHXH1210J		3/4-10	1-1/4-12	2,7966 (1804,2)	1,12 (28,5)	
	KNHXHL1210J			2,5505 (1645,5)	1,25 (31,8)	0,64 (16,26)
KNHXH1414J		7/8-14	1-3/8-12	3,4652 (2235,6)	1,25 (31,8)	
	KNHXHL1414J			3,2769 (2114,1)	1,37 (34,8)	0,63 (16,00)
KNHXH1409J		7/8-9	1-3/8-12	3,4652 (2235,6)	1,25 (31,8)	
	KNHXHL1409J			3,2769 (2114,1)	1,37 (34,8)	0,71 (18,03)
KNHXH1612J		1-12	1-1/2-12	4,2374 (2733,8)	1,37 (34,8)	
	KNHXHL1612J			4,2135 (2718,4)	1,50 (38,1)	0,70 (17,78)
KNHXH1608J		1-8	1-1/2-12	4,2374 (2733,8)	1,37 (34,8)	
	KNHXHL1608J			4,2135 (2718,4)	1,50 (38,1)	0,78 (19,81)

Part-no.	Installation dimensions					Removal dimensions	
	Ø D modified tap drill Ø inch	Ø E countersink Ø inch +0,01 (mm)	Thread F		Hand installation tool part-no.	Drill	
			Ø F class UNC-2B	G min. inch (mm)		Ø inch (mm)	Depth inch (mm)
KNHXH1216J	1,187 (30,15)	1,270 (32,26)	1-1/4-12 UNF	1,31 (33,27) 1,44 (36,58)	THXHD1216L	1-3/32 (27,78)	5/16 (7,94)
KNHXHL1216J							
KNHXH1210J	1,187 (30,15)	1,270 (32,26)	1-1/4-12 UNF	1,31 (33,27) 1,44 (36,58)	THXHD1210L	1-3/32 (27,78)	5/16 (7,94)
KNHXHL1210J							
KNHXH1414J	1,312 (33,32)	1,395 (35,43)	1-3/8-12 UNF	1,44 (36,58) 1,56 (39,62)	THXHD1414L	1-7/32 (30,96)	5/16 (7,94)
KNHXHL1414J							
KNHXH1409J	1,312 (33,32)	1,395 (35,43)	1-3/8-12 UNF	1,44 (36,58) 1,56 (39,62)	THXHD1409L	1-7/32 (30,96)	5/16 (7,94)
KNHXHL1409J							
KNHXH1612J	1,437 (36,50)	1,520 (38,61)	1-1/2-12 UNF	1,56 (39,62) 1,38 (42,67)	THXHD1612L	1-11/32 (34,13)	5/16 (7,94)
KNHXHL1612J							
KNHXH1608J	1,437 (36,50)	1,520 (38,61)	1-1/2-12 UNF	1,56 (39,62) 1,38 (42,67)	THXHD1608L	1-11/32 (34,13)	5/16 (7,94)
KNHXHL1608J							