

# BlockLift

## Principle of operation:

A standard lift type gas spring works on counterbalance basis, i.e. the extension force balances the weight to be lifted. The internals of a standard lift gas spring work with a simple piston with a transfer channel for gas and oil. The added feature of the BlockLift gas spring, is a valved piston assembly, which allows the gas spring to be locked at any desired position.

The "Piston Valve" separates the tube into two chambers, which is different to the standard lift type gas spring. Additionally the piston rod is a tube construction which operates with a "release lever" inside. This "release lever" is activated by operating the "release pin" at the end of the rod.

By pressing the "release Pin" of the BlockLift, the "release lever" moves through the piston rod and pushes the nozzle partially out of the piston (See diagram below). When the valve is open the relevant medium (Gas or Oil) can flow through the piston into the other chamber. The locking function of the BlockLift is thereby released. Now, the BlockLift performs like a standard lift gas spring on a counterbalance basis and the piston rod can compress and extend as force is applied to the system. As soon as the pressure on the release pin is taken off, the valve closes because of internal pressure in the cylinder and the gas spring locks immediately.

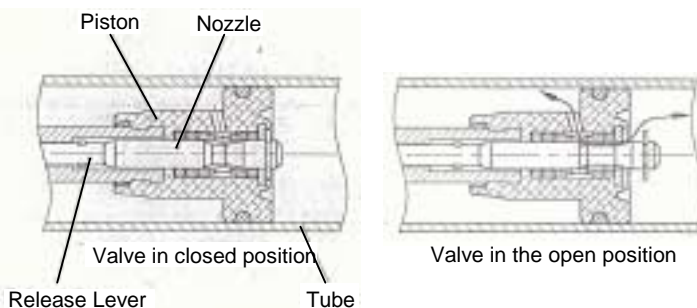

The arrow shows the Transfer of relevant Medium (oil or gas) Through the valve

## Application Examples:

**Office chairs:-** Back rest adjustment - Seat tilting - Height adjustment

**Desktops Systems:-** Height adjustment - Tilting

**Train and Bus Seats:-** Back rest adjustment - Seat tilting

**Hospital Chairs and beds:-** Back rest adjustment - Seat tilting - Height adjustment

**And many more.....**

There are two main styles of BlockLift, referred to as **Elastic (springing) or Rigid**

**Elastic BlockLift:** The elastic-locking feature is best suited for applications requiring a degree of comfort, for example in seating and chair systems.

**Rigid BlockLift:** Provides a firm and reliable position adjustment (e.g., table tops and hospital beds where no movement if required). Depending on the application, locking can be in the extension or compression direction.

# BlockLift

Summary Data Table:

	Rigid on Extension	Rigid on Compression	Elastic
Rod End Act	Y	Y	Y
	<b>This is the most popular type of BlockLift available</b>	Very rarely recommended special	Very rarely recommended special
8-22 Stroke (Min-Max) Stock item strokes welded eye end connectors	<b>10mm-500mm (20mm-120mm)</b>	No	No
8-22 Tube Length	<b>Stroke + 110mm min</b>	No	No
8-22 Force	<b>150N-800N in 50N increments</b>	No	No
10-22 Stroke (Min-Max) Stock item strokes welded eye	<b>10mm-500mm (20mm-250mm)</b>	No	10mm-500mm (15mm-160mm)
10-22 Tube Length	<b>Stroke + 110mm min</b>	No	Stroke + 80mm min
10-22 Force	<b>150N-800N in 50N increments</b>	No	150N-800N in 50N increments
10-22 Stroke (Min-Max) Stock item strokes welded eye	<b>10mm-500mm (20mm-250mm)</b>	No	No
10-22 Tube Length	<b>Stroke + 125mm min</b>	No	No
10-22 Force	<b>150N-800N in 50N increments</b>	No	No
10-28 Stroke (Min-Max) Stock item strokes welded eye	<b>10mm-500mm (20mm-250mm)</b>	10mm-500mm (25mm-250mm)	No
10-28 Tube Length	<b>Stroke + 110mm min</b>	Stroke = A Tube = approx 1.3A + 130mm	No
10-28 Force	<b>150N-800N in 50N increments</b>	150N-800N in 50N increments	No
Nitrided Rods	Y	Y	Y

If you have any questions about specifying your BlockLift requirement please e-mail us at [info.amcl@arvinmeritor.com](mailto:info.amcl@arvinmeritor.com) or call our Sales office on **+44(0)116 274 3600**.

# BlockLift

General Comments Compression Forces	<b>Compression forces. 10 times (F1) in rigid direction (Direction of Oil). Oil on rod side therefore high extension locking. AMCL check extension force and elasticity on the compression side of the spring. Compression force on elastic side 4 to 6 times F1 (N)</b>	Compression force as for Rigid in Extension.	Elastic compression force 3 to 4 times F1 (N) Elastic with high force effectively becomes a rigid spring due to high force
Actuator Pin Forces	<b>The higher the F1 the higher the actuator pin force. Std = 0.18 F1. Can be reduced, but makes it non-std. Note: Need to request hard, std or soft actuation</b>		
Actuator Pin Head Type	<b>Preferred type is plain pin end. Button end is non-standard. Button end would give longer life due to less wear potential.</b>		
Piston Rod Orientation. Must always inform AMCL of the rod orientation.	<b>With Block Lift Rigid, Rod is always in oil, therefore free orientation. NB if rod always down &amp; piston in oil then oil always in compression / extension direction. May enable removal of floating piston saving space.</b>	Must always inform AMCL of the rod orientation.	Must always inform AMCL of the rod orientation.
Colour. Cost increases would apply for non-standard colours.	<b>Standard RAL 9005 Black and RAL 9006 Grey other colours available depends on quantity and lead-time.</b>	Standard RAL 9005 Black and RAL 9006 Grey other colours available depends on quantity and lead-time.	Standard RAL 9005 Black and RAL 9006 Grey other colours available depends on quantity and lead-time.
Tube End Act		Y	Y
		Nearly Rigid for high force due to internal construction.	
10-24 stroke Stock item strokes welded eye	No	No	10-40mm
10-24 Tube length	No	No	Stroke + 60mm min
10-24 Force	No	No	200-800N in 50N increments
10-28 stroke Stock item strokes threaded rod	No	29 – 250mm	22-180mm
10-28 Tube length	No		Stroke + 70mm min
10-28 Force	No	200-800N in 50N increments	200-800N in 50N increments

**NOTES:**

**Rod End Actuation vs. Tube End Actuation.** This is Application dependant, but the vast majority are rod end activated.

**Maximum force is 800N.** But, it is possible to go higher depending on the stroke and tube combinations.

**Minimum Force!** It is definitely not possible to go below **50N** on a Block-Lift. The range between 50N and 100N (Standard) should be referred to AMCL for consideration.

**Temperature capabilities** are the same for all three types -30°C to +80°C. High temperature and Low temperature versions are available as specials -45°C to +200°C. Refer to AMCL for further information.

**Velocity.** Standard opening velocity is 0.1 to 0.2 m/sec. This can actually be increased up to 0.5 m/sec, or reduced to 0.06 m/sec if required. Refer to AMCL for further information.

**Force Tolerances.** For standard BlockLift springs this is approximately +15% to -10%. (N.b. for info, standard gas springs normal lift the tolerance is approximately +5% to -5%.)