



Jergens®

MANUFACTURING EFFICIENCY



WORKHOLDING SOLUTIONS



SPECIALTY FASTENERS



LIFTING SOLUTIONS

©2020 JERGENS, INC. | IMG0220



SPECIALTY FASTENERS

Fasten, Strengthen and Secure:

From threaded inserts and toggle clamps to Kwik-Lok® Pins.



Jergens is a world leader in innovative fastening technology for a wide range of applications. Our user-friendly products are designed with unique, problem-solving features that increase efficiency and effectiveness. With thousands of standard products available, and the ability to modify standards and manufacture custom specials. Jergens can meet your requirements while bringing simple solutions to complex applications.

KWIK-LOK® PINS.....5-30

Kwik-Lok® Pins provide quick, easy, positive engagement and high holding strength for applications requiring frequent, repetitive use. Available in a variety of diameters and lengths, their simple, smooth operation makes Kwik-Lok® Pins an ideal replacement for detent pins, clevis pins and cotter pins.

SPRING LOADED DEVICES..... 31-44

Our unique Solid Drive Design allows the entire plunger to move, eliminating the need for set screws that often result in hard-to-remove plunger bodies and lost springs.

THREADED INSERTS.....45-60

Rated among the highest in pullout strength, Jergens' keylocking inserts can easily be installed with standard drills and taps. Competitive products require special drills, taps and installation tools. MS/NAS products available.

MISCELLANEOUS FASTENERS.....61-70

From pull dowels, clevis pins, and leveling mounts to rod ends, washers, and yokes, Jergens has the fasteners you need.

HANDWHEELS, HANDLES & LEVERS.....71-114

Jergens Specialty Fasteners maintains a large inventory of several varieties of knobs, handles, hand wheels, and cranks. Whether you're looking for prototype or production quantities, we can help!

KNOBS115-150

Jergens' toggle clamps are a top quality alternative to more expensive brands. We maintain a large inventory and are happy to help identify the right product for your application.



Jergens Company Profile

Jergens Inc. was founded in 1942 by Jack Schron, Sr. and his father Christy, to provide standard components for building jigs and fixtures. Today the fourth generation of family involvement continues stronger than ever. Throughout its 75-year history the company has grown into four separate operating divisions: Tooling Component Division (TCD), Jergens Industrial Supply (JIS), Acme Industrial Company (AIC), and Advanced Systems Group (ASG) Division of Jergens. While all divisions are vital to the Jergens family, the TCD Division is the centerpiece of our manufacturing capabilities. In June 1999, Jergens moved into a new 110,000 square foot facility and prides itself by manufacturing over 80% of its product offering, as well as setting the standard for producing the highest quality components in our industry.

Jergens Tooling Component Division comprises three distinct business units: Workholding Solutions, Lifting Solutions and Specialty Fasteners. Building on its reputation of uncompromising quality standards, Jergens is committed to helping its customers achieve leaner, more profitable manufacturing, and continues to add products and engineered solutions for an integrated approach to “Manufacturing Efficiency.”

Today, you’ll find our tooling components, fasteners and hoist rings at work in just about every industry on every continent. And our innovative Quick Change Workholding Solutions like Ball Lock[®] Mounting System, Fixture-Pro[®] 5-Axis Workholding and Zero Point Systems have changed the way manufacturers worldwide think about productivity.

Jergens actively supports global, multinational and internationally based customers with metric dimensioned product offerings as well as many inch threaded products that are common in aerospace and industrial applications around the world. In important manufacturing markets in Canada, Europe, Asia and Latin America, Jergens representatives and stocking distributors have represented Jergens for more than 30 years. Our international representatives are trained technically on our products and provide expertise to customers and sub dealers in applying Jergens technologies to local industries. In recent years, two wholly owned affiliates were formed to serve the Chinese and Indian markets. Jergens (Shanghai) Commercial Co., Ltd, opened in 2006 and Jergens India Private Ltd., Navi Mumbai India opened in 2009. These fully registered trading subsidiaries employ trained multi-lingual engineers and commercial managers who provide marketing and importing, warehousing, distribution and technical support to our customers, distributors and local representatives.

Additionally, we offer a wide range of metalworking tools, clamps, and supplies to manufacturers in Northeastern Ohio, through our JIS Division. Acme Industrial, located in Carpentersville, Illinois, is a premium manufacturer of precision drill bushings and keylocking thread inserts. Our ASG Division specializes in products for light assembly ranging from torque-controlled electric screwdrivers to automation systems.

In addition to our unique product designs, we lead the industry with unparalleled customer service and delivery. Our website is a good example of our commitment to be the most innovative company in our industry. Customers and distributors can check stock and order on-line, view the Jergens catalog, and even download 2D, 3D and solid model CAD drawings in a variety of formats. Visit our website at www.jergensinc.com for the latest news and product information, as well as links to our other divisions. The Jergens family thanks you for your business.

Distribution of Jergens Products

Jergens is proud to be represented by a network of qualified distributors throughout the world. If you do not know the name of the distributor nearest you, please call Jergens Customer Service at 1-866-KWIK-LOK or visit www.jergensinc.com.

Quality Policy

Jergens, Inc. manufactures and supplies only *quality* products. Our quality system is ISO 9001: 2015 Certified. Center-Pull and Side-Pull Hoist Rings are CE Certified. If there is a problem with any of our products, please contact your local Jergens Distributor or contact our Customer Service Department.

Design Aids

Jergens, Inc. offers several CAD drawing formats for use in fixture design. Our Fixture Pro[®] software is available on CD. Our internet site (www.jergensinc.com) offers our complete catalog with hot links to CAD drawings on most of our products. We also offer 3D solid models of our products via the internet.

Application Assistance

Jergens Inc. maintains a complete Technical Sales Department to work with you. Please feel free to call upon their knowledge and experience. Application videos are available for the Ball Lock[®] Mounting System, 5-Axis Fixture Pro[®], and Hydraulic Vise Column products at www.jergensinc.com or www.youtube.com/users/jergensinc.

Engineering Changes

Product improvement is a continuing process at Jergens, Inc. Specifications and engineering data are subject to change without notice. **If current information is critical to your design, it is suggested that you contact the Jergens Customer Service Department, or download the most current drawing from our website*, to verify any dimensions or specifications.**

* 3D Solid Models are available in multiple formats from www.jergensinc.com

Bar Coding

Jergens' boxed and bagged products are fully bar coded for automatic identification. The bar code labels contain the ASCII Code 39 format, which was chosen as being suitable for most bar code readers. Jergens' bar codes will identify part numbers and manufacturer's codes.

Specials

Jergens, Inc. will modify any item that is similar to our standard component parts. Please contact your Jergens Distributor with your request for a quote. Prints or sketches should be furnished if possible.

TCMA Standards

Products throughout this catalog meet the standards of the Tooling Component Manufacturers' Association. The items are asterisked and are interchangeable with other tooling component manufacturer's products.

Material and Finish Specifications

Stressproof[®]: A severely cold worked, furnace treated steel bar. Produced by LaSalle patented process to obtain high strength, free machinability, good wear, and minimum warpage in the bar.

Alloy Steel - 4140 or equivalent

Low Carbon Steel - Free Machining 1215, 1018, or equivalent

52100: QQS-624

Zinc Plate: ASTM B633, Type III, Class FE/ZN 5

Cadmium Plate: AMS-QQ-P-416, Class 3, Type 1

Black Oxide: MIL-DTL-13924 and AMS-2485

Black Anodize: per Mil. Spec. MIL-A-8625, Type II, Class 2 and AMS-2472

Passivate: AMS 2700

Alternate Finishes available upon request.

Jergens, Inc.
Manufacturing Number: 697830
FSCM #94882

ISO 9001: 2015
Registration #00010133

KWIK-LOK® PINS

Kwik-Lok® Pins

Button Handle Pins

Aluminum Handle	12-13
Stainless Handle	12-13
Recessed Stainless.....	7

Detent Pins	20-21
-------------------	-------

Double Acting Pin

T, L & Ring.....	18-19
Lanyards.....	26-27

L-Handle Pins

Aluminum Handle	10-11
Stainless Handle	16-17
Marine Pins	23-25

Ring Handle Pins

Stainless Steel	14-15
Selection and Ordering.....	6
Special Pin Quotation.....	30
Specifications and Materials	28-29

T-Handle Pins

Aluminum Handle	8-9
Stainless Handle	16-17



Kwik-Lok® Pins – Selection and Ordering

1. Choose Handle Shape and Style:

- T, L, or Button
- Heavy Duty T, L, or Button
- Ring Handle, Lifting Ring, or Recessed Button
- Double Acting (Push/Pull) T or L

Material

- Aluminum
- Stainless Steel
- Stainless Steel
- Stainless Steel

2. Select Pin Body Material

- 17-4-PH heat treated Stainless Steel for highest strength, corrosion and scratch resistance

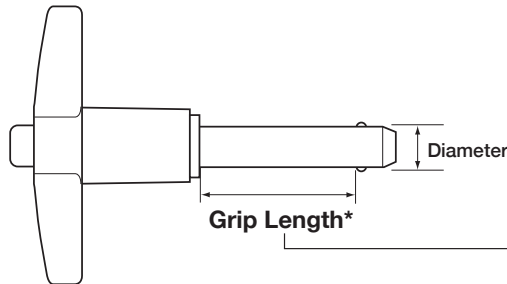

*Grip Length is measured to edge of locking ball
 Standard Grip Lengths: 1/2"-6", 10-100 mm
 Special Grip Lengths available on request

3. Specify Pin Diameter and Grip Length

Standard Kwik-Lok® Pin Diameters			Double Shear Resistance (Minimum)		
Nominal	Min/Max (Inches)	Min/Max (mm)	Stainless Steel (17-4 PH)		
			lbs	kN	
3/16"		0.1870 / 0.1885	4.75 / 4.79	5150	23
—	5 mm	0.1937 / 0.1953	4.92 / 4.96	5395	24
—	6 mm	0.2331 / 0.2346	5.92 / 5.96	7868	35
1/4"		0.2470 / 0.2485	6.27 / 6.31	9200	41
5/16"		0.3095 / 0.3110	7.86 / 7.90	14400	64
—	8 mm	0.3118 / 0.3134	7.92 / 7.96	14695	65
3/8"		0.3720 / 0.3735	9.45 / 9.49	20700	92
—	10 mm	0.3906 / 0.3921	9.92 / 9.96	22480	100
7/16"		0.4345 / 0.4360	11.04 / 11.07	28500	127
—	12 mm	0.4693 / 0.4709	11.92 / 11.96	32371	144
1/2"		0.4970 / 0.4985	12.62 / 12.66	36900	164
9/16"		0.5595 / 0.5610	14.21 / 14.25	46700	208
5/8"		0.6220 / 0.6235	15.80 / 15.84	57800	257
—	16 mm	0.6268 / 0.6283	15.92 / 15.96	57774	257
3/4"		0.7470 / 0.7485	18.97 / 19.01	83200	370
—	20 mm	0.7843 / 0.7858	19.92 / 19.96	90594	403
7/8"		0.8720 / 0.8735	22.15 / 22.19	112500	500
—	25 mm	0.9811 / 0.9827	24.92 / 24.96	141849	631
1"		0.9970 / 0.9985	25.32 / 25.36	147200	655

See Page 28 for recommended mounting hole diameters and minimum locking ball tensile strength for estimating pullout resistance.

4. Locate Standard Part Numbers from Charts by Diameter and Grip Length.

5. Select Lanyards and Tabs on pages 26-27:

- Specify Length of Cable (Stainless Steel) with Green Nylon Jacket (other colors available)
- Choose Tab Style, Material and Mounting Hole Dimension
- Specify if Lanyard is to be crimped to Pin without Split Ring

May be ordered with 4 locking balls for additional locking element tensile strength.
 Special Materials, grip length and longer "C" dimensions upon request.



Recessed Button Handle Kwik-Lok® Pin



- The Recessed Button Handle Kwik-Lok® Pin design helps prevent accidental actuation of the pin.
- Handle is 300 Series stainless steel and the button is 17-4 PH stainless steel.
- Body is made from high Strength Stainless Steel, 17-4 PH heat treated.
- Includes hole for easy attachment of optional lanyard or ring.

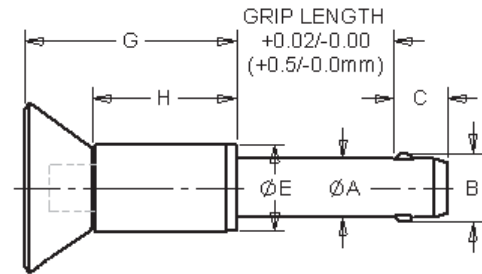
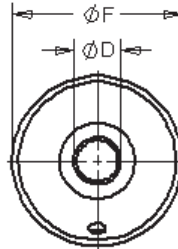

Recessed Button Handle Specifications – Inch

DIA	A MIN	A MAX	B +/--.005	C +0.00 / -0.04	D MIN	D MAX	E MIN	E MAX	F +/--.020	G +/--.020	H +/--.020
3/16	0.1870	0.1885	0.220	0.260	0.250	0.310	0.310	0.530	0.800	0.990	0.710
1/4	0.2470	0.2485	0.289	0.290	0.250	0.310	0.310	0.530	0.800	0.990	0.710
5/16	0.3095	0.3110	0.375	0.330	0.250	0.310	0.410	0.590	0.800	1.050	0.780
3/8	0.3720	0.3735	0.440	0.365	0.300	0.390	0.450	0.650	1.090	1.375	0.930
7/16	0.4345	0.4360	0.509	0.380	0.300	0.390	0.450	0.650	1.090	1.375	0.930
1/2	0.4970	0.4985	0.594	0.460	0.435	0.565	0.600	0.800	1.040	1.320	0.930

Recessed Button Handle Specifications – Metric

DIA	A MIN	A MAX	B +/--.13	C +0.00 / -1.00	D MIN	D MAX	E MIN	E MAX	F +/--.020	G +/--.020	H +/--.020
5MM	4.92	4.96	5.54	6.0	6.4	7.9	7.9	13.5	20.3	25.1	18.0
6MM	5.92	5.96	6.99	7.0	6.4	7.9	7.9	13.5	20.3	25.1	18.0
8MM	7.92	7.96	9.42	8.0	6.4	7.9	7.9	13.5	20.3	26.7	19.8
10MM	9.92	9.96	11.86	9.0	7.6	9.9	11.4	16.5	27.7	34.9	23.6
12MM	11.92	11.96	14.45	10.0	7.6	9.9	11.4	16.5	27.7	34.9	23.6

Pin Dia	Grip Length (In)												
	0.5	0.75	1	1.25	1.5	1.75	2	2.5	3*	4*	5*	6	
PART NUMBERS	3/16	803000	803001	803002	803003	803004	803005	803006	803008	803009	803011	803013	803015
	1/4	803016	803017	803018	803019	803020	803021	803022	803024	803025	803027	803029	803031
	5/16	803032	803033	803034	803035	803036	803037	803038	803040	803041	803043	803045	803047
	3/8	803048	803049	803050	803051	803052	803053	803054	803056	803057	803059	803061	803063
	7/16	803064	803065	803066	803067	803068	803069	803070	803072	803073	803075	803077	803079
	1/2	803080	803081	803082	803083	803084	803085	803086	803088	803089	803091	803093	803095

Contact customer service for other sizes.

Pin Dia	Grip Length (Metric)												
	10	15	20	25	30	40	50	60	70	80	90	100	
PART NUMBERS	5	853000	853001	853002	853003	853004	853005	853006	853007	853008	853009	853010	853011
	6	853012	853013	853014	853015	853016	853017	853018	853019	853020	853021	853022	853023
	8	853024	853025	853026	853027	853028	853029	853030	853031	853032	853033	853034	853035
	10	853036	853037	853038	853039	853040	853041	853042	853043	853044	853045	853046	853047
	12	853048	853049	853050	853051	853052	853053	853054	853055	853056	853057	853058	853059

Contact customer service for other sizes.

May be ordered with 4 locking balls for additional locking element tensile strength.
Special Materials, grip length and longer “C” dimensions upon request.



T-Handle Kwik-Lok® Pin MS17985, NAS1333-NAS1343 A2=Aluminum T Handle



- The T-Handle Kwik-Lok® Pin provides a firm, even grip for smooth comfortable operation.
- Handle is Anodized black cast aluminum and the button is 2024 blue anodized aluminum.
- Pin body: Heat Treated 17-4 PH Stainless Steel.
- Includes hole and split ring for easy attachment of optional lanyard.

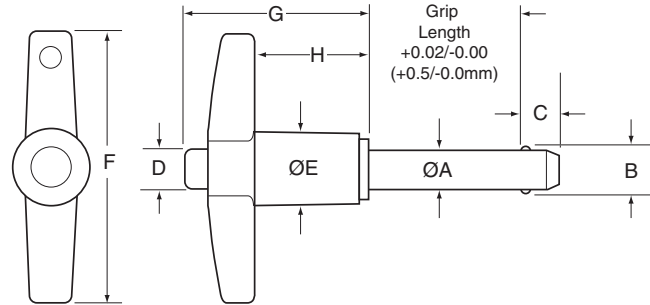

T-Handle Specifications – Inch

DIA	A MIN	A MAX	B +/- .005	C +0.00 / -0.04	D MIN	D MAX	E MIN	E MAX	F MIN	F MAX	G MAX	H MIN
3/16	0.1875	0.1885	0.220	0.260	0.250	0.310	0.380	0.500	1.750	1.815	1.270	0.800
1/4	0.2470	0.2485	0.289	0.290	0.250	0.310	0.380	0.500	1.750	1.815	1.270	0.800
5/16	0.3095	0.3110	0.375	0.330	0.250	0.310	0.380	0.500	1.750	1.815	1.270	0.800
3/8	0.3720	0.3735	0.440	0.365	0.300	0.390	0.510	0.625	1.935	2.065	1.450	0.850
7/16	0.4345	0.4360	0.509	0.380	0.300	0.390	0.510	0.625	1.935	2.065	1.470	0.850
1/2	0.4970	0.4985	0.594	0.460	0.435	0.565	0.630	0.800	2.220	2.345	1.600	0.885
9/16	0.5595	0.5610	0.666	0.510	0.435	0.565	0.630	0.800	2.220	2.345	1.600	0.885
5/8	0.6220	0.6235	0.750	0.580	0.450	0.580	0.810	0.940	2.250	3.100	1.700	0.980
3/4	0.7470	0.7485	0.887	0.670	0.570	0.700	0.810	1.000	2.500	3.100	1.720	1.030
7/8	0.8720	0.8735	1.046	0.760	0.700	0.840	1.120	1.300	2.750	3.520	2.170	1.310
1	0.9970	0.9985	1.209	0.890	0.750	0.950	1.180	1.320	2.750	3.520	2.170	1.310

T-Handle Specifications – Metric

DIA	A MIN	A MAX	B +/- .13	C +0.00 / -1.00	D MIN	D MAX	E MIN	E MAX	F MIN	F MAX	G MAX	H MIN
5MM	4.92	4.96	5.54	6.0	6.4	7.9	9.7	12.7	44.5	46.1	32.3	20.3
6MM	5.92	5.96	6.99	7.0	6.4	7.9	9.7	12.7	44.5	46.1	32.3	20.3
8MM	7.92	7.96	9.42	8.0	6.4	7.9	9.7	12.7	44.5	46.1	32.3	20.3
10MM	9.92	9.96	11.86	9.0	7.6	9.9	13.0	15.9	49.1	52.5	36.8	21.6
12MM	11.92	11.96	14.45	10.0	7.6	9.9	13.0	15.9	49.1	52.5	36.8	21.6
16MM	15.92	15.96	19.00	14.0	11.4	14.7	20.6	23.9	57.2	78.7	43.2	24.9
20MM	19.92	19.96	24.08	17.0	14.5	17.8	20.6	25.4	63.5	78.7	43.7	26.2
25MM	24.92	24.96	30.94	22.0	19.1	24.1	30.0	33.5	69.9	89.4	55.1	33.3

Dimensions in millimeters

May be ordered with 4 locking balls for additional locking element tensile strength.
Special Materials, grip length and longer “C” dimensions upon request.



T-Handle – Inch

Aluminum Handle, Body – High Strength Stainless Steel, 17-4 PH Heat Treated

Pin Dia	Grip Length (In)												
	0.5	0.75	1	1.25	1.5	1.75	2	2.5	3	4	5	6	
PART NUMBER	3/16	801000	801001	801002	801003	801004	801005	801006	801008	801009	801011	801013	801015
	1/4	801016	801017	801018	801019	801020	801021	801022	801024	801025	801027	801029	801031
	5/16	801032	801033	801034	801035	801036	801037	801038	801040	801041	801043	801045	801047
	3/8	801048	801049	801050	801051	801052	801053	801054	801056	801057	801059	801061	801063
	7/16	801064	801065	801066	801067	801068	801069	801070	801072	801073	801075	801077	801079
	1/2	801080	801081	801082	801083	801084	801085	801086	801088	801089	801091	801093	801095
	9/16	801096	801097	801098	801099	801100	801101	801102	801104	801105	801107	801109	801111
	5/8	801112	801113	801114	801115	801116	801117	801118	801120	801121	801123	801125	801127
	3/4	801128	801129	801130	801131	801132	801133	801134	801136	801137	801139	801141	801143
	7/8	801144	801145	801146	801147	801148	801149	801150	801152	801153	801155	801157	801159
1	801160	801161	801162	801163	801164	801165	801166	801168	801169	801171	801173	801175	

T-Handle – Metric

Aluminum Handle, Body – High Strength Stainless Steel, 17-4 PH Heat Treated

Pin Dia	Grip Length (Metric)												
	10	15	20	25	30	40	50	60	70	80	90	100	
PART NUMBER	5	851000	851001	851002	851003	851004	851005	851006	851007	851008	851009	851010	851011
	6	851012	851013	851014	851015	851016	851017	851018	851019	851020	851021	851022	851023
	8	851024	851025	851026	851027	851028	851029	851030	851031	851032	851033	851034	851035
	10	851036	851037	851038	851039	851040	851041	851042	851043	851044	851045	851046	851047
	12	851048	851049	851050	851051	851052	851053	851054	851055	851056	851057	851058	851059
	16	851060	851061	851062	851063	851064	851065	851066	851067	851068	851069	851070	851071
	20	851072	851073	851074	851075	851076	851077	851078	851079	851080	851081	851082	851083
	25	851084	851085	851086	851087	851088	851089	851090	851091	851092	851093	851094	851095

Contact customer service for other sizes.



May be ordered with 4 locking balls for additional locking element tensile strength.



L-Handle Kwik-Lok® Pin MS17986, NAS1333-NAS1343 A5=Aluminum L Handle



- The L-Handle Kwik-Lok® Pin provides a firm grip for applications where a T-Handle will not fit.
- Handle is Anodized black cast aluminum and the button is 2024 blue anodized aluminum.
- Pin body Heat Treated 17-4 PH Stainless Steel.
- Includes hole and split ring for easy attachment of optional lanyard.

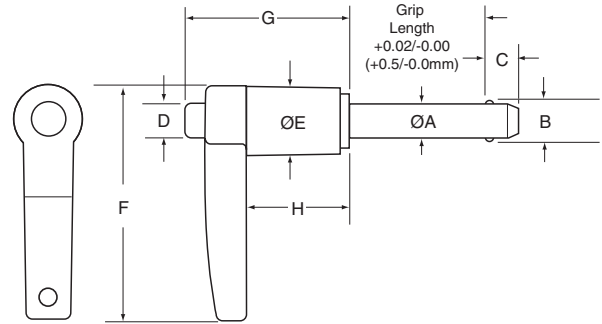

L-Handle Specifications – Inch

DIA	A MIN	A MAX	B +/- .005	C +0.00 / -0.04	D MIN	D MAX	E MIN	E MAX	F MIN	F MAX	G MAX	H MIN
3/16	0.1875	0.1885	0.220	0.260	0.250	0.310	0.380	0.500	1.720	1.800	1.270	0.760
1/4	0.2470	0.2485	0.289	0.290	0.250	0.310	0.380	0.500	1.720	1.800	1.270	0.760
5/16	0.3095	0.3110	0.375	0.330	0.250	0.310	0.380	0.500	1.720	1.800	1.270	0.760
3/8	0.3720	0.3735	0.440	0.365	0.300	0.390	0.510	0.625	1.945	2.030	1.450	0.850
7/16	0.4345	0.4360	0.509	0.380	0.300	0.390	0.510	0.625	1.945	2.030	1.450	0.850
1/2	0.4970	0.4985	0.594	0.460	0.435	0.565	0.630	0.800	2.230	2.360	1.600	0.850
9/16	0.5595	0.5610	0.666	0.510	0.435	0.565	0.630	0.800	2.230	2.360	1.600	0.850
5/8	0.6220	0.6235	0.750	0.580	0.450	0.580	0.810	0.975	2.385	3.070	1.700	0.905
3/4	0.7470	0.7485	0.887	0.670	0.570	0.700	0.810	1.000	2.465	3.070	1.720	0.980
7/8	0.8720	0.8735	1.046	0.760	0.700	0.840	1.120	1.320	2.750	3.700	2.170	1.200
1	0.9970	0.9985	1.209	0.890	0.750	0.950	1.180	1.320	2.750	3.700	2.170	1.200

L-Handle Specifications – Metric

DIA	A MIN	A MAX	B +/- .13	C +0.00 / -1.00	D MIN	D MAX	E MIN	E MAX	F MIN	F MAX	G MAX	H MIN
5MM	4.92	4.96	5.54	6.0	6.4	7.9	7.9	12.7	43.7	45.7	32.3	19.3
6MM	5.92	5.96	6.99	7.0	6.4	7.9	7.9	12.7	43.7	45.7	32.3	19.3
8MM	7.92	7.96	9.42	8.0	6.4	7.9	7.9	12.7	43.7	45.7	32.3	19.3
10MM	9.92	9.96	11.86	9.0	7.6	9.9	13.0	15.9	49.4	51.6	36.8	21.6
12MM	11.92	11.96	14.45	10.0	7.6	9.9	13.0	15.9	49.4	51.6	36.8	21.6
16MM	15.92	15.96	19.00	14.0	11.4	14.7	20.6	24.8	60.6	78.0	43.2	23.0
20MM	19.92	19.96	24.08	17.0	14.5	17.8	20.6	25.4	62.6	78.0	43.7	24.9
25MM	24.92	24.96	30.94	22.0	19.1	24.1	30.0	33.5	69.9	94.0	55.1	30.5

Dimensions in millimeters

May be ordered with 4 locking balls for additional locking element tensile strength.
Special Materials, grip length and longer “C” dimensions upon request.



L-Handle – Inch

Aluminum Handle, Body – High Strength Stainless Steel, 17-4 PH Heat Treated

Pin Dia	Grip Length (In)												
	0.5	0.75	1	1.25	1.5	1.75	2	2.5	3	4	5	6	
PART NUMBERS	3/16	801400	801401	801402	801403	801404	801405	801406	801408	801409	801411	801413	801415
	1/4	801416	801417	801418	801419	801420	801421	801422	801424	801425	801427	801429	801431
	5/16	801432	801433	801434	801435	801436	801437	801438	801440	801441	801443	801445	801447
	3/8	801448	801449	801450	801451	801452	801453	801454	801456	801457	801459	801461	801463
	7/16	801464	801465	801466	801467	801468	801469	801470	801472	801473	801475	801477	801479
	1/2	801480	801481	801482	801483	801484	801485	801486	801488	801489	801491	801493	801495
	9/16	801496	801497	801498	801499	801500	801501	801502	801504	801505	801507	801509	801511
	5/8	801512	801513	801514	801515	801516	801517	801518	801520	801521	801523	801525	801527
	3/4	801528	801529	801530	801531	801532	801533	801534	801536	801537	801539	801541	801543
	7/8	801544	801545	801546	801547	801548	801549	801550	801552	801553	801555	801557	801559
	1	801560	801561	801562	801563	801564	801565	801566	801568	801569	801571	801573	801575

L-Handle – Metric

Aluminum Handle, Body – High Strength Stainless Steel, 17-4 PH Heat Treated

Pin Dia	Grip Length (Metric)												
	10	15	20	25	30	40	50	60	70	80	90	100	
PART NUMBERS	5	851400	851401	851402	851403	851404	851405	851406	851407	851408	851409	851410	851411
	6	851412	851413	851414	851415	851416	851417	851418	851419	851420	851421	851422	851423
	8	851424	851425	851426	851427	851428	851429	851430	851431	851432	851433	851434	851435
	10	851436	851437	851438	851439	851440	851441	851442	851443	851444	851445	851446	851447
	12	851448	851449	851450	851451	851452	851453	851454	851455	851456	851457	851458	851459
	16	851460	851461	851462	851463	851464	851465	851466	851467	851468	851469	851470	851471
	20	851472	851473	851474	851475	851476	851477	851478	851479	851480	851481	851482	851483
	25	851484	851485	851486	851487	851488	851489	851490	851491	851492	851493	851494	851495

Contact customer service for other sizes.



May be ordered with 4 locking balls for additional locking element tensile strength.



Button Handle Kwik-Lok® Pin MS17984, NAS 1333-1343



A3=Aluminum Button Handle

- The Button Handle Kwik-Lok® Pin is ideal for applications that have limited space around the handle.
- Light weight 2024 Aluminum Alloy handle with 2024 blue anodized aluminum button.
- Pin body Heat Treated 17-4 PH Stainless Steel.
- Includes hole and split ring for easy attachment of optional lanyard.



C3=Stainless Button Handle

- Heavy Duty solid handle in 303 series stainless steel provides additional impact resistance
- Includes hole and split ring for easy attachment of optional lanyard.
- All stainless steel construction provides additional corrosion resistance
- Body is made from high Strength Stainless Steel, 17-4 PH heat treated
- Meets or exceeds NASM 23460 specifications
- May be ordered with 4 locking balls for additional locking element tensile strength

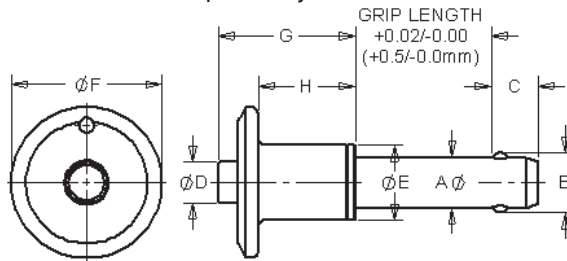

Button Handle Specifications – Inch

DIA	A MIN	A MAX	B +/- .005	C +0.00 / -0.04	D MIN	D MAX	E MIN	E MAX	F MIN	F MAX	G MAX	H MIN
3/16	0.1875	0.1885	0.220	0.260	0.250	0.310	0.310	0.440	0.720	0.800	0.830	0.480
1/4	0.2470	0.2485	0.289	0.290	0.250	0.310	0.310	0.440	0.720	0.800	0.890	0.480
5/16	0.3095	0.3110	0.375	0.330	0.250	0.310	0.410	0.490	0.810	1.135	0.930	0.480
3/8	0.3720	0.3735	0.440	0.365	0.300	0.390	0.450	0.570	0.875	1.135	1.040	0.620
7/16	0.4345	0.4360	0.509	0.380	0.300	0.390	0.550	0.625	0.940	1.400	1.160	0.620
1/2	0.4970	0.4985	0.594	0.460	0.435	0.565	0.600	0.725	1.300	1.400	1.190	0.720
9/16	0.5595	0.5610	0.666	0.510	0.435	0.565	0.680	0.760	1.400	1.650	1.410	0.950
5/8	0.6220	0.6235	0.750	0.580	0.450	0.580	0.750	0.865	1.530	1.700	1.500	0.950
3/4	0.7470	0.7485	0.887	0.670	0.570	0.700	0.865	1.000	1.790	1.900	1.680	1.140
7/8	0.8720	0.8735	1.046	0.760	0.700	0.840	0.865	1.000	2.120	2.250	1.985	1.270
1	0.9970	0.9985	1.209	0.890	0.750	0.950	1.175	1.250	2.120	2.250	2.140	1.490

Button Handle Specifications – Metric

DIA	A MIN	A MAX	B +/- .13	C +0.00 / -1.00	D MIN	D MAX	E MIN	E MAX	F MIN	F MAX	G MAX	H MIN
5MM	4.92	4.96	5.54	6.0	6.4	7.9	7.9	11.2	18.3	20.3	21.1	12.2
6MM	5.92	5.96	6.99	7.0	6.4	7.9	7.9	11.2	18.3	20.3	22.6	12.2
8MM	7.92	7.96	9.42	8.0	6.4	7.9	10.4	12.4	20.6	28.8	23.6	12.2
10MM	9.92	9.96	11.86	9.0	7.6	9.9	11.4	14.5	22.2	28.8	26.4	15.7
12MM	11.92	11.96	14.45	10.0	7.6	9.9	14.0	15.9	23.9	35.6	29.5	15.7
16MM	15.92	15.96	19.00	14.0	11.4	14.7	19.1	22.0	38.9	43.2	38.1	24.1
20MM	19.92	19.96	24.08	17.0	14.5	17.8	22.0	25.4	45.5	48.3	42.7	29.0
25MM	24.92	24.96	30.94	22.0	19.1	24.1	29.8	31.8	53.8	57.2	54.4	37.8

Dimensions in millimeters

May be ordered with 4 locking balls for additional locking element tensile strength.
Special Materials, grip length and longer “C” dimensions upon request.



Button Handle – Inch

Aluminum Button, Heat Treated Stainless Steel 17-4 PH Body

Table with columns: Pin Dia, Grip Length (In) (0.5 to 6), and Part Numbers (3/16 to 1).

Stainless Steel Button, Heat Treated Stainless Steel 17-4 PH Body

Table with columns: Pin Dia, Grip Length (In) (0.5 to 6), and Part Numbers (3/16 to 1).

Button Handle – Metric

Aluminum Button, Heat Treated Stainless Steel 17-4 PH Body

Table with columns: Pin Dia, Grip Length (Metric) (10 to 100), and Part Numbers (5 to 25).

Stainless Steel Button, Heat Treated Stainless Steel 17-4 PH Body

Table with columns: Pin Dia, Grip Length (Metric) (10 to 100), and Part Numbers (5 to 25).

Contact customer service for other sizes.

May be ordered with 4 locking balls for additional locking element tensile strength.



Ring-Handle Kwik-Lok® Pin MS17987, NAS1333-NAS1343 C6=Stainless Ring Handle



- The Ring-Handle Kwik-Lok® Pin is designed for applications which require small clearance area around the pin.
- 303 Series Stainless steel handle for tough environment with 303 stainless button.
- Pin body: Heat Treated 17-4 PH Stainless Steel.
- Ring allows for easy attachment of optional lanyard.

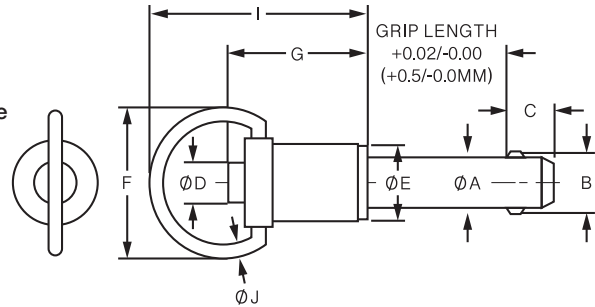

Ring-Handle Specifications – Inch

DIA	A MIN	A MAX	B +/- .005	C +0.00 / -0.04	D MIN	D MAX	E MIN	E MAX	F MIN	G MIN	G MAX	I MAX	J MIN
3/16	0.1875	0.1885	0.220	0.260	0.250	0.310	0.310	0.530	1.060	0.730	1.490	1.450	0.080
1/4	0.2470	0.2485	0.289	0.290	0.250	0.310	0.310	0.530	1.060	0.780	1.490	1.500	0.080
5/16	0.3095	0.3110	0.375	0.330	0.250	0.310	0.410	0.590	1.060	0.830	1.490	1.650	0.080
3/8	0.3720	0.3735	0.440	0.365	0.300	0.390	0.450	0.650	1.060	0.940	1.490	1.650	0.080
7/16	0.4345	0.4360	0.509	0.380	0.300	0.390	0.550	0.710	1.090	0.980	1.580	1.850	0.080
1/2	0.4970	0.4985	0.594	0.460	0.435	0.565	0.600	0.800	1.160	1.140	1.580	1.850	0.080
9/16	0.5595	0.5610	0.666	0.510	0.435	0.565	0.680	0.840	1.160	1.140	1.580	2.030	0.080
5/8	0.6220	0.6235	0.750	0.580	0.450	0.580	0.750	0.905	1.240	1.400	1.840	2.250	0.120
3/4	0.7470	0.7485	0.887	0.670	0.570	0.700	0.865	1.045	1.640	1.625	1.990	2.650	0.120
7/8	0.8720	0.8735	1.046	0.760	0.700	0.840	0.980	1.235	1.640	1.875	2.190	3.000	0.120
1	0.9970	0.9985	1.209	0.890	0.750	0.950	1.175	1.330	1.640	2.000	2.450	3.100	0.120

Ring-Handle Specifications – Metric

DIA	A MIN	A MAX	B +/- .13	C +0.00 / -1.00	D MIN	D MAX	E MIN	E MAX	F MIN	G MIN	G MAX	I MAX	J MIN
5MM	4.92	4.96	5.54	6.0	6.4	7.9	7.9	13.5	26.9	18.5	37.8	36.8	2.0
6MM	5.92	5.96	6.99	7.0	6.4	7.9	7.9	13.5	26.9	18.5	37.8	36.8	2.0
8MM	7.92	7.96	9.42	8.0	6.4	7.9	7.9	13.5	26.9	18.5	37.8	36.8	2.0
10MM	9.92	9.96	11.86	9.0	7.6	9.9	11.4	16.5	26.9	23.9	37.8	36.8	2.0
12MM	11.92	11.96	14.45	10.0	7.6	9.9	14.0	18.0	27.7	24.9	40.1	47.0	2.0
16MM	15.92	15.96	19.00	14.0	11.4	14.7	19.1	23.0	31.5	35.6	46.7	57.2	3.0
20MM	19.92	19.96	24.08	17.0	14.5	17.8	22.0	26.5	41.7	41.3	50.5	67.3	3.0
25MM	24.92	24.96	30.94	22.0	19.1	24.1	29.8	33.8	41.7	50.8	62.2	78.7	3.0

Dimensions in millimeters

May be ordered with 4 locking balls for additional locking element tensile strength.
Special Materials, grip length and longer “C” dimensions upon request.



Ring-Handle – Inch

Stainless Steel – High Strength Stainless Steel, 17-4 PH Heat Treated

Pin Dia	Grip Length (In)												
	0.5	0.75	1	1.25	1.5	1.75	2	2.5	3	4	5	6	
PART NUMBERS	3/16	800200	800201	800202	800203	800204	800205	800206	800208	800209	800211	800213	800215
	1/4	800216	800217	800218	800219	800220	800221	800222	800224	800225	800227	800229	800231
	5/16	800232	800233	800234	800235	800236	800237	800238	800240	800241	800243	800245	800247
	3/8	800248	800249	800250	800251	800252	800253	800254	800256	800257	800259	800261	800263
	7/16	800264	800265	800266	800267	800268	800269	800270	800272	800273	800275	800277	800279
	1/2	800280	800281	800282	800283	800284	800285	800286	800288	800289	800291	800293	800295
	9/16	800296	800297	800298	800299	800300	800301	800302	800304	800305	800307	800309	800311
	5/8	800312	800313	800314	800315	800316	800317	800318	800320	800321	800323	800325	800327
	3/4	800328	800329	800330	800331	800332	800333	800334	800336	800337	800339	800341	800343
	7/8	800344	800345	800346	800347	800348	800349	800350	800352	800353	800355	800357	800059
	1	800360	800361	800362	800363	800364	800365	800366	800368	800369	800371	800373	800375

Ring-Handle – Metric

Stainless Steel – High Strength Stainless Steel, 17-4 PH Heat Treated

Pin Dia	Grip Length (Metric)												
	10	15	20	25	30	40	50	60	70	80	90	100	
PART NUMBERS	5	850200	850201	850202	850203	850204	850205	850206	850207	850208	850209	850210	850211
	6	850212	850213	850214	850215	850216	850217	850218	850219	850220	850221	850222	850223
	8	850224	850225	850226	850227	850228	850229	850230	850231	850232	850233	850234	850235
	10	850236	850237	850238	850239	850240	850241	850242	850243	850244	850245	850246	850247
	12	850248	850249	850250	850251	850252	850253	850254	850255	850256	850257	850258	850259
	16	850260	850261	850262	850263	850264	850265	850266	850267	850268	850269	850270	850271
	20	850272	850273	850274	850275	850276	850277	850278	850279	850280	850281	850282	850283
	25	850284	850285	850286	850287	850288	850289	850290	850291	850292	850293	850294	850295

Contact customer service for other sizes.

KWIK-LOK® PINS

May be ordered with 4 locking balls for additional locking element tensile strength.



Heavy Duty T&L Handle Pins 17985, 17986, NAS1333-NAS1343

C2=Stainless T Handle
C5=Stainless L Handle



- Also known as Ground Handling Pins
- Heavy Duty welded handle provides additional impact resistance
- Includes split ring for easy attachment of optional lanyard.
- 303 Series Stainless Steel handle and button provide additional corrosion resistance
- Body is made from high Strength Stainless Steel, 17-4 PH heat treated.
- Meets or exceeds NASM 23460 specifications
- May be ordered with 4 locking balls for additional locking element tensile strength

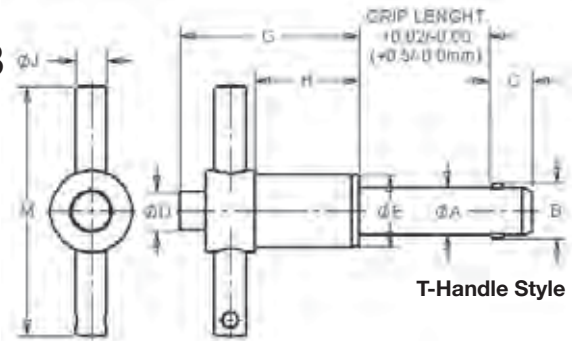

T-Handle Style

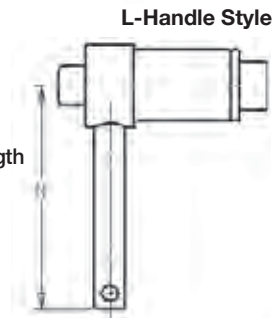

L-Handle Style

Heavy Duty T&L Handle Specifications – Inch

Nom Pin Dia	Pin Dia A		±0.005 B	+0.00/-0.04 C	D	E	G	H	J	M	N
	Min	Max									
3/16 (#10)	.1870	.1885	.220	.260	1/4	7/16	1 1/4	13/16	3/16	1 15/16	1 3/4
1/4	.2470	.2485	.289	.290	1/4	7/16	1 1/4	13/16	3/16	1 15/16	1 3/4
5/16	.3095	.3110	.375	.330	1/4	7/16	1 1/4	13/16	3/16	1 15/16	1 3/4
3/8	.3720	.3735	.440	.365	5/16	9/16	1 11/32	13/16	1/4	1 15/16	1 3/4
7/16	.4345	.4360	.509	.380	5/16	9/16	1 11/32	13/16	1/4	2 1/8	1 3/4
1/2	.4970	.4985	.594	.460	7/16	11/16	1 7/16	13/16	1/4	2 3/8	1 31/32
9/16	.5595	.5610	.666	.510	7/16	11/16	1 7/16	13/16	1/4	2 3/8	1 31/32
5/8	.6220	.6235	.750	.580	1/2	15/16	1 11/16	31/32	5/16	2 7/8	2 15/32
3/4	.7470	.7485	.887	.670	37/64	15/16	1 23/32	31/32	5/16	2 7/8	2 15/32
7/8	.8720	.8735	1.046	.760	3/4	1 3/16	2 5/32	1 1/4	3/8	3 1/4	2 13/16
1	.9970	.9985	1.219	.890	3/4	1 3/16	2 5/32	1 1/4	3/8	3 1/4	2 13/16

Heavy Duty T&L Handle Specifications – Metric

Nom Pin Dia	Pin Dia A ± 0.13		+0.0/- 1.0 B	C	D	E	G	H	J	M	N
	Min	Max									
5	4.92	4.96	5.54	6	6.5	10.8	31.7	20.4	4.76	49.5	44.5
6	5.92	5.96	6.99	7	6.5	10.8	31.7	20.4	4.76	49.5	44.5
8	7.92	7.96	9.40	8	6.5	10.8	31.7	20.4	4.76	49.5	44.5
10	9.92	9.96	11.86	9	7.7	14.2	34.1	21.0	6.35	49.5	44.5
12	11.92	11.96	14.45	10	7.7	14.2	34.2	21.0	6.35	54.1	50.0
16	15.92	15.96	19.00	14	12.4	23.9	42.6	24.6	7.94	73.2	62.7
20	19.92	19.96	24.08	17	12.4	23.9	42.6	24.9	7.94	73.2	62.7
25	24.92	24.96	30.94	22	19.2	30.0	53.4	30.2	9.53	82.3	71.0

Dimensions in millimeters

May be ordered with 4 locking balls for additional locking element tensile strength.
Special Materials, grip length and longer “C” dimensions upon request.



Heavy Duty T-Handle – Inch

Table with columns: Pin Dia, Grip Length (inches) [0.5, 0.75, 1, 1.25, 1.5, 1.75, 2, 2.5, 3, 4, 5, 6]. Rows include pin diameters 3/16, 1/4, 5/16, 3/8, 7/16, 1/2, 9/16, 5/8, 3/4, 7/8, and 1.

Heavy Duty L-Handle – Inch

Table with columns: Pin Dia, Grip Length (inches) [0.5, 0.75, 1, 1.25, 1.5, 1.75, 2, 2.5, 3, 4, 5, 6]. Rows include pin diameters 3/16, 1/4, 5/16, 3/8, 7/16, 1/2, 9/16, 5/8, 3/4, 7/8, and 1.

Heavy Duty T-Handle – Metric

Table with columns: Pin Dia, Grip Length (mm) [10, 15, 20, 25, 30, 40, 50, 60, 70, 80, 90, 100]. Rows include pin diameters 5, 6, 8, 10, 12, 16, 20, and 25.

Heavy Duty L-Handle – Metric

Table with columns: Pin Dia, Grip Length (mm) [10, 15, 20, 25, 30, 40, 50, 60, 70, 80, 90, 100]. Rows include pin diameters 5, 6, 8, 10, 12, 16, 20, and 25.

Contact customer service for special sizes & materials.

May be ordered with 4 locking balls for additional locking element tensile strength.



Double Acting T, L, Ring Handles MS17988, MS17989, MS17990 NAS1353-NAS1366



Push/Pull Activation

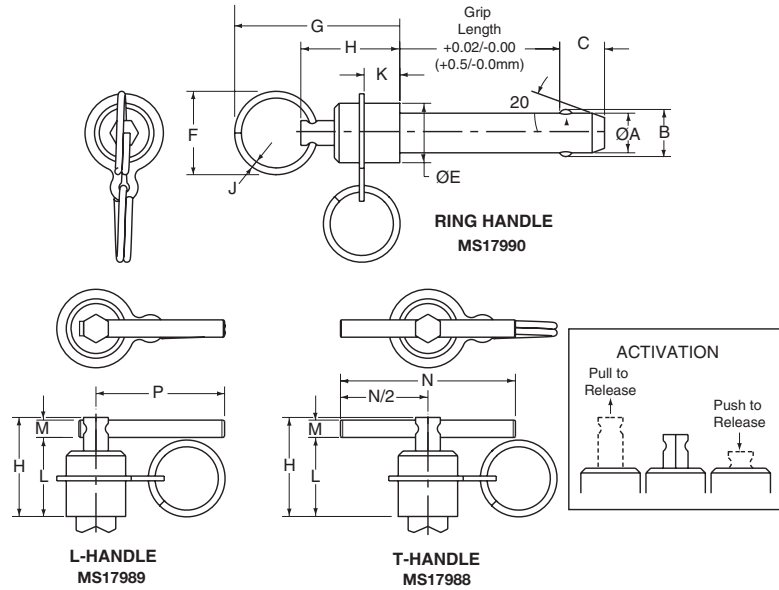

- Double Acting Pins are activated by push or pull motion
- All stainless steel construction provides additional corrosion resistance
- Body is made from high Strength Stainless Steel, 17-4 PH heat treated.
- Ideal for quick insertion and removal
- Four ball options available upon request
- Includes split ring for easy attachment of optional lanyard.
- Meets or exceeds NASM 23460 specifications
- Drive Out feature available upon request
- Handle + button made from 303 S.S.

Double Acting Specifications – Inch

Nom Pin Dia	Pin Dia A		B ±0.005	C Max	E		F		Max G	H	J	K		Min L	Dia M	N	P
	Min	Max			Min	Max	Min	Max				Min	Max				
3/16 (#10)	.1870	.1885	.220	.410	.360	.450	1.000	1.125	1.945	1.030	.080	.415	.480	.780	.109	1.500	1.300
1/4	.2470	.2485	.289	.410	.360	.450	1.000	1.125	1.945	1.030	.080	.415	.480	.780	.109	1.500	1.300
5/16	.3095	.3110	.375	.440	.390	.505	1.000	1.125	1.945	1.030	.080	.415	.480	.780	.109	1.500	1.300
3/8	.3720	.3735	.440	.510	.510	.630	1.000	1.125	2.025	1.090	.080	.445	.540	.830	.156	2.000	1.500
7/16	.4345	.4360	.509	.510	.510	.630	1.000	1.125	2.025	1.090	.080	.445	.540	.830	.156	2.000	1.500
1/2	.4970	.4985	.594	.590	.640	.755	1.000	1.125	2.200	1.270	.080	.445	.540	.880	.218	2.250	1.655
9/16	.5595	.5610	.666	.660	.640	.755	1.000	1.125	2.200	1.270	.080	.445	.540	.880	.218	2.250	1.655
5/8	.6220	.6235	.750	.750	.805	.870	1.312	1.500	2.690	1.465	.120	.510	.575	1.000	.250	2.500	1.810
3/4	.7470	.7485	.887	.790	.890	.960	1.312	1.500	2.690	1.465	.120	.530	.595	1.000	.250	2.500	1.810
7/8	.8720	.8735	1.046	.950	1.070	1.150	1.312	1.500	2.860	1.640	.120	.665	.730	1.180	.250	2.875	2.250
1	.9970	.9985	1.219	1.110	1.200	1.280	1.312	1.500	3.010	1.830	.120	.800	.865	1.320	.250	2.875	2.250

Double Acting Specifications – Metric

Nom Pin Dia	Pin Dia A		B ±0.13	C Max	E		F		Max G	H	J	K		Min L	Dia M	N	P
	Min	Max			Min	Max	Min	Max				Min	Max				
5	4.92	4.96	5.54	10.41	9.14	11.43	25.40	28.58	49.40	26.16	2.03	10.54	12.19	19.81	2.78	38.10	33.02
6	5.92	5.96	6.99	10.41	9.14	11.43	25.40	28.58	49.40	26.16	2.03	10.54	12.19	19.81	2.78	38.10	33.02
8	7.92	7.96	9.42	11.68	9.91	12.83	25.40	28.58	49.40	26.16	2.03	10.54	12.19	19.81	2.78	38.10	33.02
10	9.92	9.96	11.86	13.21	12.95	16.00	25.40	28.58	51.44	27.69	2.03	11.30	13.72	21.08	3.97	49.21	38.10
12	11.92	11.96	14.45	13.72	12.95	16.00	25.40	28.58	51.44	27.69	2.03	11.30	13.72	21.08	3.97	49.21	38.10
16	15.92	15.96	19.00	19.18	20.45	22.10	33.32	38.10	68.33	37.21	3.04	12.95	14.61	25.40	6.35	61.91	45.97
20	19.92	19.96	24.08	20.57	22.61	24.38	33.32	38.10	68.33	37.21	3.04	13.46	15.11	25.40	6.35	61.91	45.97
25	24.92	24.96	30.94	28.83	30.48	32.51	33.32	38.10	76.45	46.48	3.04	20.32	21.97	33.53	6.35	71.45	57.15

Dimensions in millimeters

May be ordered with 4 locking balls for additional locking element tensile strength. Special Materials, grip length and longer "C" dimensions upon request.



Pin Dia	Grip Length (inches)											
	0.5	0.75	1	1.25	1.5	1.75	2	2.5	3	4	5	6
Double Acting Ring Handle – Inch – MS17990												
3/16	806200	806201	806202	806203	806204	806205	806206	806208	806209	806211	806213	806215
1/4	806216	806217	806218	806219	806220	806221	806222	806224	806225	806227	806229	806231
5/16	806232	806233	806234	806235	806236	806237	806238	806240	806241	806243	806245	806247
3/8	806248	806249	806250	806251	806252	806253	806254	806256	806257	806259	806261	806263
7/16	806264	806265	806266	806267	806268	806269	806270	806272	806273	806275	806277	806279
1/2	806280	806281	806282	806283	806284	806285	806286	806288	806289	806291	806293	806295
9/16	806296	806297	806298	806299	806300	806301	806302	806304	806305	806307	806309	806311
5/8	806312	806313	806314	806315	806316	806317	806318	806320	806321	806323	806325	806327
3/4	806328	806329	806330	806331	806332	806333	806334	806336	806337	806339	806341	806343
7/8	806344	806345	806346	806347	806348	806349	806350	806352	806353	806355	806357	806359
1	806360	806361	806362	806363	806364	806365	806366	806368	806369	806371	806373	806375
Double Acting T-Handle – Inch – MS17988												
3/16	803400	803401	803402	803403	803404	803405	803406	803408	803409	803411	803413	803415
1/4	803416	803417	803418	803419	803420	803421	803422	803424	803425	803427	803429	803431
5/16	803432	803433	803434	803435	803436	803437	803438	803440	803441	803443	803445	803447
3/8	803448	803449	803450	803451	803452	803453	803454	803456	803457	803459	803461	803463
7/16	803464	803465	803466	803467	803468	803469	803470	803472	803473	803475	803477	803479
1/2	803480	803481	803482	803483	803484	803485	803486	803488	803489	803491	803493	803495
9/16	803496	803497	803498	803499	803500	803501	803502	803504	803505	803507	803509	803511
5/8	803512	803513	803514	803515	803516	803517	803518	803520	803521	803523	803525	803527
3/4	803528	803529	803530	803531	803532	803533	803534	803536	803537	803539	803541	803543
7/8	803544	803545	803546	803547	803548	803549	803550	803552	803553	803555	803557	803559
1	803560	803561	803562	803563	803564	803565	803566	803568	803569	803571	803573	803575
Double Acting L-Handle – Inch – MS17989												
3/16	806000	806001	806002	806003	806004	806005	806006	806008	806009	806011	806013	806015
1/4	806016	806017	806018	806019	806020	806021	806022	806024	806025	806027	806029	806031
5/16	806032	806033	806034	806035	806036	806037	806038	806040	806041	806043	806045	806047
3/8	806048	806049	806050	806051	806052	806053	806054	806056	806057	806059	806061	806063
7/16	806064	806065	806066	806067	806068	806069	806070	806072	806073	806075	806077	806079
1/2	806080	806081	806082	806083	806084	806085	806086	806088	806089	806091	806093	806095
9/16	806096	806097	806098	806099	806100	806101	806102	806104	806105	806107	806109	806111
5/8	806112	806113	806114	806115	806116	806117	806118	806120	806121	806123	806125	806127
3/4	806128	806129	806130	806131	806132	806133	806134	806136	806137	806139	806141	806143
7/8	806144	806145	806146	806147	806148	806149	806150	806152	806153	806155	806157	806159
1	806160	806161	806162	806163	806164	806165	806166	806168	806169	806171	806173	806175

Pin Dia	Grip Length (mm)											
	10	15	20	25	30	40	50	60	70	80	90	100
Double Acting Ring Handle – Metric												
5	855000	855001	855002	855003	855004	855005	855006	855007	855008	855009	855010	855011
6	855012	855013	855014	855015	855016	855017	855018	855019	855020	855021	855022	855023
8	855024	855025	855026	855027	855028	855029	855030	855031	855032	855033	855034	855035
10	855036	855037	855038	855039	855040	855041	855042	855043	855044	855045	855046	855047
12	855048	855049	855050	855051	855052	855053	855054	855055	855056	855057	855058	855059
16	855060	855061	855062	855063	855064	855065	855066	855067	855068	855069	855070	855071
20	855072	855073	855074	855075	855076	855077	855078	855079	855080	855081	855082	855083
25	855084	855085	855086	855087	855088	855089	855090	855091	855092	855093	855094	855095
Double Acting T-Handle – Metric												
5	853400	853401	853402	853403	853404	853405	853406	853407	853408	853409	853410	853411
6	853412	853413	853414	853415	853416	853417	853418	853419	853420	853421	853422	853423
8	853424	853425	853426	853427	853428	853429	853430	853431	853432	853433	853434	853435
10	853436	853437	853438	853439	853440	853441	853442	853443	853444	853445	853446	853447
12	853448	853449	853450	853451	853452	853453	853454	853455	853456	853457	853458	853459
16	853460	853461	853462	853463	853464	853465	853466	853467	853468	853469	853470	853471
20	853472	853473	853474	853475	853476	853477	853478	853479	853480	853481	853482	853483
25	853484	853485	853486	853487	853488	853489	853490	853491	853492	853493	853494	853495
Double Acting L-Handle – Metric												
5	854600	854601	854602	854603	854604	854605	854606	854607	854608	854609	854610	854611
6	854612	854613	854614	854615	854616	854617	854618	854619	854620	854621	854622	854623
8	854624	854625	854626	854627	854628	854629	854630	854631	854632	854633	854634	854635
10	854636	854637	854638	854639	854640	854641	854642	854643	854644	854645	854646	854647
12	854648	854649	854650	854651	854652	854653	854654	854655	854656	854657	854658	854659
16	854660	854661	854662	854663	854664	854665	854666	854667	854668	854669	854670	854671
20	854672	854673	854674	854675	854676	854677	854678	854679	854680	854681	854682	854683
25	854684	854685	854686	854687	854688	854689	854690	854691	854692	854693	854694	854695

Contact customer service for special sizes & materials.

May be ordered with 4 locking balls for additional locking element tensile strength.



Heavy Duty Detent Pins

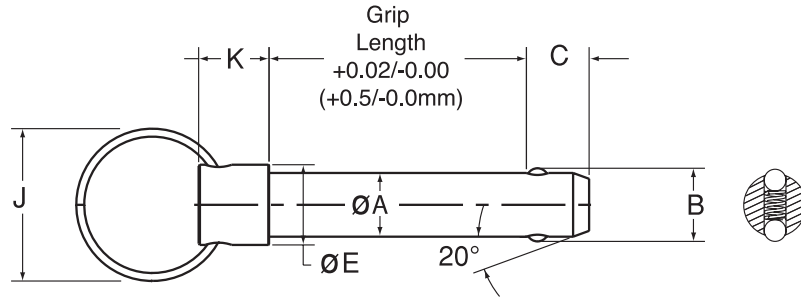
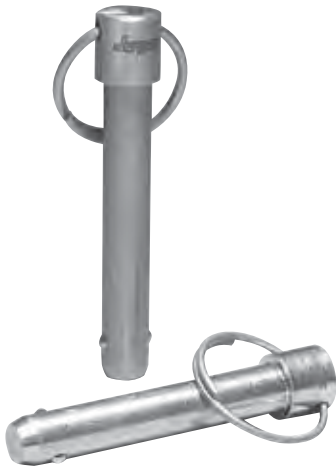

The Heavy Duty Detent Kwik-Lok® Pin is a high quality shoulder style alignment pin for applications that don't require the positive locking ball feature.

- Heavy duty spring and 2 spring loaded stainless steel locking balls provide high pull out force
- Body 17-4 PH heat treated stainless steel
- Includes split ring for easy attachment of optional lanyard
- Handle is 303 S.S.

Heavy Duty Detent Specifications – Inch

Nom. Pin Dia	Dia. +0.000/-0.003 A	Min. B	+0.00/-0.06 C	Dia. +/-0.015 E	Dia. J	K	Double Shear Strength – (lbs)	Pull Out Force (lbs)	Recommended Hole Diameter	
							Stainless 17-4 PH		Max	Min
3/16 (#10)	.1885	.200	.250	.375	1.187	.50	5,262	2 to 7	0.1940	0.1900
1/4	.2480	.280	.344	.375	1.187	.50	9,537	2 to 7	0.2540	0.2500
5/16	.3105	.360	.359	.438	1.187	.50	15,075	2 to 7	0.3165	0.3125
3/8	.3730	.430	.390	.500	1.187	.50	22,050	6 to 14	0.3790	0.3750
7/16	.4355	.495	.469	.625	1.187	.55	30,438	6 to 14	0.4425	0.4375
1/2	.4980	.570	.516	.625	1.187	.55	39,263	10 to 22	0.5050	0.5000
9/16	.5605	.645	.593	.625	1.687	.55	49,731	15 to 30	0.5675	0.5625
5/8	.6230	.720	.672	.750	1.687	.55	61,736	15 to 30	0.6300	0.6250
3/4	.7480	.860	.750	.875	1.687	.55	88,442	15 to 30	0.7570	0.7500
7/8	.8730	1.030	.859	1.000	2.187	.55	121,500	20 to 35	0.8820	0.8750
1	.9980	1.160	.984	1.125	2.187	.55	158,998	20 to 40	1.0100	1.0000

Heavy Duty Detent Specifications – Metric

Nom. Pin Dia	Dia. +0.000/-0.080 A	Min. B	+0.0/-1.5 C	Dia. +/- 0.4 E	Dia. J	K	Double Shear Strength – (kN)	Pull Out Force	Recommended Hole Diameter	
							Stainless 17-4 PH		Max	Min
5	4.95	5.23	6.35	9.53	30.15	12.7	25	9 to 31	5.1	5
6	5.95	6.88	8.74	9.53	30.15	12.7	36	9 to 31	6.1	6
8	7.95	9.35	9.12	11.13	30.15	12.7	69	9 to 31	8.1	8
10	9.95	11.58	9.91	12.70	30.15	12.7	107	26 to 62	10.1	10
12	11.95	13.84	13.11	15.88	30.15	14.2	154	44 to 97	12.1	12
16	15.95	18.54	17.07	19.05	42.85	14.2	275	66 to 133	16.1	16
20	19.95	22.91	19.05	22.23	42.85	14.2	433	89 to 155	20.15	20
25	24.95	29.18	24.99	28.58	55.55	14.2	682	89 to 178	25.15	25

Dimensions in millimeters

May be ordered with 4 locking balls for additional locking element tensile strength. Special Materials, grip length and longer "C" dimensions upon request.



Heavy Duty Detent Pins – Inch

Stainless Steel – Stainless Steel, 17-4 PH

Pin Dia	Grip Length (In)												
	0.5	0.75	1	1.25	1.5	1.75	2	2.5	3	4	5	6	
PART NUMBERS	3/16	804200	804201	804202	804203	804204	804205	804206	804208	804209	804211	804213	804215
	1/4	804216	804217	804218	804219	804220	804221	804222	804224	804225	804227	804229	804231
	5/16	804232	804233	804234	804235	804236	804237	804238	804240	804241	804243	804245	804247
	3/8	804248	804249	804250	804251	804252	804253	804254	804256	804257	804259	804261	804263
	7/16	804264	804265	804266	804267	804268	804269	804270	804272	804273	804275	804277	804279
	1/2	804280	804281	804282	804283	804284	804285	804286	804288	804289	804291	804293	804295
	9/16	804296	804297	804298	804299	804300	804301	804302	804304	804305	804307	804309	804311
	5/8	804312	804313	804314	804315	804316	804317	804318	804320	804321	804323	804325	804327
	3/4	804328	804329	804330	804331	804332	804333	804334	804336	804337	804339	804341	804343
	7/8	804344	804345	804346	804347	804348	804349	804350	804352	804353	804355	804357	804359
	1	804360	804361	804362	804363	804364	804365	804366	804368	804369	804371	804373	804375

Heavy Duty Detent Pins – Metric

Stainless Steel – Stainless Steel, 17-4 PH

Pin Dia	Grip Length (Metric)												
	10	15	20	25	30	40	50	60	70	80	90	100	
PART NUMBERS	5	854000	854001	854002	854003	854004	854005	854006	854007	854008	854009	854010	854011
	6	854012	854013	854014	854015	854016	854017	854018	854019	854020	854021	854022	854023
	8	854024	854025	854026	854027	854028	854029	854030	854031	854032	854033	854034	854035
	10	854036	854037	854038	854039	854040	854041	854042	854043	854044	854045	854046	854047
	12	854048	854049	854050	854051	854052	854053	854054	854055	854056	854057	854058	854059
	16	854060	854061	854062	854063	854064	854065	854066	854067	854068	854069	854070	854071
	20	854072	854073	854074	854075	854076	854077	854078	854079	854080	854081	854082	854083
	25	854084	854085	854086	854087	854088	854089	854090	854091	854092	854093	854094	854095

Contact customer service for special sizes, materials or mil-spec (MIL-P-45952/1).

May be ordered with 4 locking balls for additional locking element tensile strength.



Jergens
KWIK-LOK[®]
 MARINE PINS



Jergens Kwik-Lok[®] Release Pins for Marine Applications

The most corrosive resistant pin for the most harsh, marine environments. Available in Ring Handle, Recessed Button Handle and Heavy Duty Detent styles. Pin styles that are ideal for applications that require a tight clearance, safe actuation and high pull out force.

- The Ring-Handle Marine Pin is designed for applications which require a small clearance area around the pin.
- The Recessed Button Handle Marine Pin design helps prevent accidental actuation of the pin.
- The Heavy Duty Detent Pin provides a high pull out force with its heavy duty spring and locking balls.
- The Marine Pin's Stainless Steel handles withstand tough environmental conditions.

Component Part	Material
Handle	300 Series Stainless Steel
Button	300 Series Stainless Steel
Body	Recessed & Ring Handle - 17-4 PH Stainless Steel
	Heavy Duty Detent - 300 Series Stainless Steel
Spindle	17-4 PH Stainless Steel
Spring	300 Series Stainless Steel
Balls	300 Series Stainless Steel

Pin Dia (in)	Double Shear Resistance Minimum (lbs)	
	Recessed & Ring Handle	Heavy Duty Detent
3/16	5,150	2,530
1/4	9,200	4,500
5/16	14,400	7,100
3/8	20,700	10,300
1/2	36,900	18,400
5/8	57,800	28,900
3/4	83,200	41,800

Lanyards available upon request.

All Jergens Kwik-lok[®] pins are manufactured in the USA and are MS, NAS, DFARS, QLSM and RoHS compliant. ISO 9001:2008

May be ordered with 4 locking balls for additional locking element tensile strength.



Kwik-Lok® Marine Pins Recessed Button Handle



- The Recessed Button Handle Kwik-Lok® Pin design helps prevent accidental actuation of the pin.
- Handle and button made from 303 Series Stainless Steel.
- Body is made from high Strength Stainless Steel, 17-4 PH heat treated.
- Includes hole for easy attachment of optional lanyard or ring.
- 300 Series Stainless Steel Balls

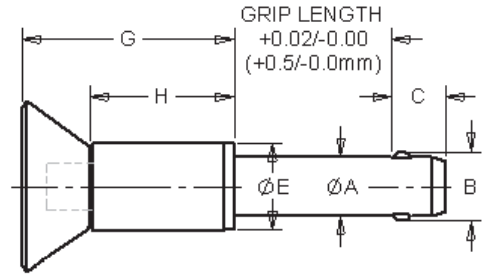
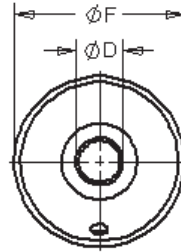

Recessed Button Handle Marine Pin Specifications – Inch

DIA	A MIN	A MAX	B +/- .005	C +0.00 / -0.04	D MIN	D MAX	E MIN	E MAX	F +/- .020	G +/- .020	H +/- .020
3/16	0.1870	0.1885	0.220	0.260	0.250	0.310	0.310	0.530	0.800	0.990	0.710
1/4	0.2470	0.2485	0.289	0.290	0.250	0.310	0.310	0.530	0.800	0.990	0.710
5/16	0.3095	0.3110	0.375	0.330	0.250	0.310	0.410	0.590	0.800	1.050	0.780
3/8	0.3720	0.3735	0.440	0.365	0.300	0.390	0.450	0.650	1.090	1.375	0.930
1/2	0.4970	0.4985	0.594	0.460	0.435	0.565	0.600	0.800	1.040	1.320	0.930

Pin Dia	Grip Length (In)											
	0.5	0.75	1	1.25	1.5	1.75	2	2.5	3	4	5	
PART NUMBERS	3/16	883000	883001	883002	883003	883004	883005	883006	883008	883009	-	-
	1/4	883016	883017	883018	883019	883020	883021	883022	883024	883025	883027	-
	5/16	883032	883033	883034	883035	883036	883037	883038	883040	883041	883043	-
	3/8	883048	883049	883050	883051	883052	883053	883054	883056	883057	883059	883061
	1/2	883080	883081	883082	883083	883084	883085	883086	883088	883089	883091	883093

Contact customer service for other sizes.

May be ordered with 4 locking balls for additional locking element tensile strength.
Special Materials, grip length and longer “C” dimensions upon request.



Kwik-Lok® Marine Pins Ring-Handle



- The Ring-Handle Kwik-Lok® Pin is designed for applications which require small clearance area around the pin.
- 303 Series Stainless steel handle and button for tough environment with stainless button.
- Pin body: Heat Treated 17-4 PH Stainless Steel.
- Ring allows for easy attachment of optional lanyard.
- 300 Series Stainless Steel Balls

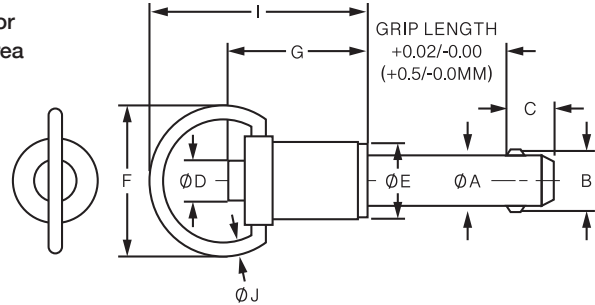

Ring-Handle Marine Pin Specifications – Inch

DIA	A MIN	A MAX	B +/- .005	C +0.00 / -.04	D MIN	D MAX	E MIN	E MAX	F MIN	G MIN	G MAX	I MAX	J MIN
3/16	0.1875	0.1885	0.220	0.260	0.250	0.310	0.310	0.530	1.060	0.730	1.490	1.450	0.080
1/4	0.2470	0.2485	0.289	0.290	0.250	0.310	0.310	0.530	1.060	0.780	1.490	1.500	0.080
5/16	0.3095	0.3110	0.375	0.330	0.250	0.310	0.410	0.590	1.060	0.830	1.490	1.650	0.080
3/8	0.3720	0.3735	0.440	0.365	0.300	0.390	0.450	0.650	1.060	0.940	1.490	1.650	0.080
1/2	0.4970	0.4985	0.594	0.460	0.435	0.565	0.600	0.800	1.160	1.140	1.580	1.850	0.080
5/8	0.6220	0.6235	0.750	0.580	0.450	0.580	0.750	0.905	1.240	1.400	1.840	2.250	0.120
3/4	0.7470	0.7485	0.887	0.670	0.570	0.700	0.865	1.045	1.640	1.625	1.990	2.650	0.120

Pin Dia	Grip Length (In)											
	0.5	0.75	1	1.25	1.5	1.75	2	2.5	3	4	5	
PART NUMBERS	3/16	880200	880201	880202	880203	880204	880205	880206	880208	880209	-	-
	1/4	880216	880217	880218	880219	880220	880221	880222	880224	880225	880227	-
	5/16	880232	880233	880234	880235	880236	880237	880238	880240	880241	880243	-
	3/8	880248	880249	880250	880251	880252	880253	880254	880256	880257	880259	880261
	1/2	880280	880281	880282	880283	880284	880285	880286	880288	880289	880291	880293
	5/8	880312	880313	880314	880315	880316	880317	880318	880320	880321	880323	880325
	3/4	880328	880329	880330	880331	880332	880333	880334	880336	880337	880339	880341

Contact customer service for other sizes.

May be ordered with 4 locking balls for additional locking element tensile strength.
Special Materials, grip length and longer “C” dimensions upon request.



Kwik-Lok® Marine Pins Heavy Duty Detent



The Heavy Duty Detent Kwik-Lok® Pin is a high quality shoulder style alignment pin for applications that don't require the positive locking ball feature.

- Heavy duty spring and 2 spring loaded stainless steel locking balls provide high pull out force
- Includes split ring for easy attachment of optional lanyard
- 300 Series Stainless steel handle and body

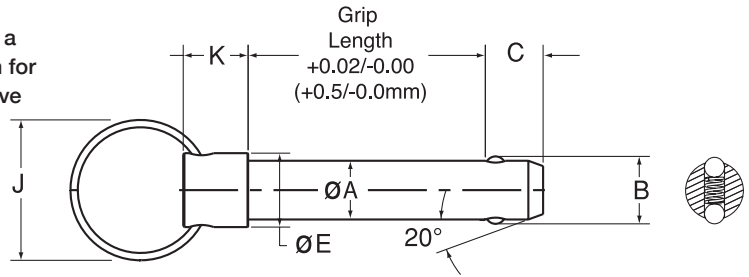

Heavy Duty Detent Specifications – Inch

DIA	A +0.00 / -0.003	B MIN	C +0.00 / -0.06	E DIA +/-0.15 / -0.04	J DIA	K	Double Shear Strength - (lbs) Stainless 17-4 PH	Pull Out Force (lbs)	Recommended Hole Dia	
									MAX	MIN
3/16 (#10)	0.1885	0.200	0.250	0.375	1.187	0.50	5,262	2 to 7	0.1940	0.1900
1/4	0.2480	0.280	0.344	0.375	1.187	0.50	9,537	2 to 7	0.2540	0.2500
5/16	0.3105	0.360	0.359	0.438	1.187	0.50	15,075	2 to 7	0.3165	0.3125
3/8	0.3730	0.430	0.390	0.500	1.187	0.50	22,050	6 to 14	0.3790	0.3750
1/2	0.4980	0.570	0.516	0.625	1.187	0.55	39,263	10 to 22	0.5050	0.5000
5/8	0.6230	0.720	0.672	0.750	1.687	0.55	61,736	15 to 30	0.6300	0.6250
3/4	0.7480	0.860	0.750	0.875	1.687	0.55	88,442	15 to 30	0.7570	0.7500

Pin Dia	Grip Length (In)											
	0.5	0.75	1	1.25	1.5	1.75	2	2.5	3	4	5	
PART NUMBERS	3/16	883800	883801	883802	883803	883804	883805	883806	883808	883809	-	-
	1/4	883816	883817	883818	883819	883820	883821	883822	883824	883825	883827	-
	5/16	883832	883833	883834	883835	883836	883837	883838	883840	883841	883843	-
	3/8	883848	883849	883850	883851	883852	883853	883854	883856	883857	883859	883861
	1/2	883880	883881	883882	883883	883884	883885	883886	883888	883889	883891	883893
	5/8	883912	883913	883914	883915	883916	883917	883918	883920	883921	883923	883925
	3/4	883928	883929	883930	883931	883932	883933	883934	883936	883937	883939	883941

Contact customer service for other sizes.

May be ordered with 4 locking balls for additional locking element tensile strength.
Special Materials, grip length and longer "C" dimensions upon request.



Lanyard Specifications & Styles

Lanyard Specifications:

- 302/304 Stainless Steel cable, 1/16" (1.59 mm), with green nylon jacket, 1/8" (3.18 mm), meets Mil-DTL-83420
- Other cable diameters, other jacket colors (blue, black, clear) and special configuration styles by special order.

Stainless Steel Round Tab

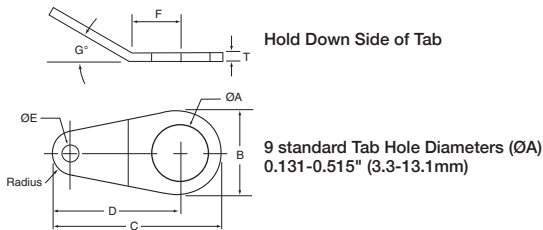

Aluminum Oval Tab

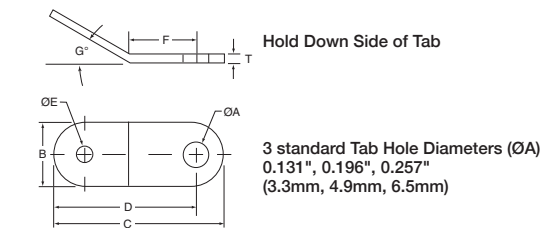

Consult Table 1, Page 27 for Options.

Standard (W/Tab)



Standard (2 Loops)

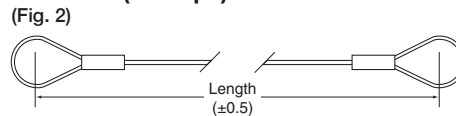

Standard (1 Loop)

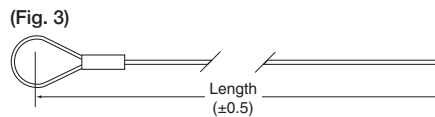

Loop/Eyelet, Stainless Steel

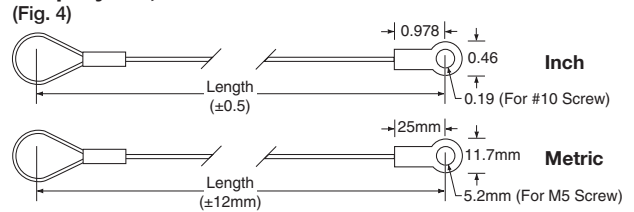

Tab Dimensions – Inch

Tab Style	±0.005 ØA	±0.01 B	±0.02 C	±0.02 D	±0.005 ØE	±0.016 Radius	±0.01 F	± 5 deg. G	±0.01 T	Material
Round Tab	See Table 1	0.688	1.316	1.004	0.125	0.160	0.406	12	0.060	300 Series Stain. Steel
Oval Tab	See Table 1	0.375	1.130	0.945	0.125	—	0.500	12	0.060	Aluminum

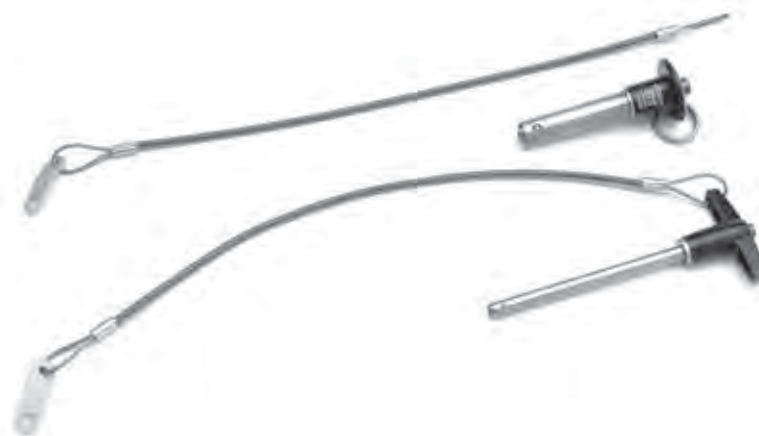

Lanyards are not weight bearing, they are only meant to support the weight of the pins-rated only @ 100 lbs.



Ordering Lanyards Attached to Pins

Lanyard with a Tab (Fig. 1)

Length		Round Tab	Oval Tab
inch	mm	Stainless Steel	Aluminum
4	102	(Pin#) A*	(Pin#) M*
6	152	B*	N*
8	203	C*	P*
10	254	D*	Q*
12	305	H*	R*
16	406	J*	S*
20	508	K*	T*
24	610	L*	U*

Substitute the asterisk (*) with the proper hole size letter from Table 1.

Table 1 Tab Hole Size

Tab Mounting Hole Diameter		
Inch	mm	Size Letter
0.131	3.3	P
0.196	4.9	Q
0.257	6.5	R
0.283 [†]	7.1 [†]	S
0.320 [†]	8.1 [†]	T
0.379 [†]	9.6 [†]	U
0.406 [†]	10.3 [†]	V
0.468 [†]	11.8 [†]	W
0.515 [†]	13.1 [†]	Y

(†) These sizes only available in stainless steel round tabs

Lanyard without a Tab

Length		2 Loops	1 Loops (Pin)
inch	mm	(Fig. 2)	(Fig. 3)
4	102	(Pin#)EA	(Pin#)FA
6	152	EB	FB
8	203	EC	FC
10	254	ED	FD
12	305	EE	FE
16	406	EF	FF
20	508	EG	FG
24	610	EH	FH

Lanyard Loop/Eyelet (Fig. 4)

For Screw Size	
#10	M5
(Pin#)GA	(Pin#)HA
GB	HB
GC	HC
GD	HD
GE	HE
GF	HF
GG	HG
GH	HH

Part Numbering:

Lanyards with Tab, attached to Pins

To order Kwik-Lok® pins with attached lanyard and tab (fig. 1), photo on page 26. Specify the six digit pin number followed by two letters from the tables above to define the lanyard length, type of lanyard and tab mounting hole diameter. The first letter designates the length of the lanyard and the type of Tab. The second letter (from table 1) designates the size of the hole in the tab for the mounting screw.

Example A: For an Aluminum T-Handle with stainless steel pin body 1/2" x 1.0", with an attached 8" Lanyard and Round Stainless Steel Tab with a mounting hole diameter of 0.257" (6.5 mm), the part number is 801082CR.

Lanyards with 2 loops, 1 loop, or loop/eyelet

To order Kwik-Lok® pins with lanyard and 2 loops (fig. 2), 1 loop (fig. 3) or loop/eyelet (fig. 4), specify the six digit pin number followed by a two letter combination from above to define lanyard length, number of loops or loop/eyelet with mounting screw size.

Example B: For all Stainless Steel L Handle Pin, 1"x 6", with attached 24" (610 mm) lanyard and 2 Loops, the part number is 805775EH.

Example C: For all Stainless Steel Button Handle Pin, 6 x 40 mm, with attached 10" (254 mm) lanyard and Loop/Eyelet for M5 screws, the part number is 855417HD.

Note: Split rings are not included when attaching lanyards, unless customer specified. In that case add an R as a third letter to the extension.

Ordering Lanyards When Supplied Separately Without Pins

Lanyards with Tabs (Fig. 1)

Length		Round Tab	Oval Tab
inch	mm	Stainless Steel	Aluminum
4	102	890054*	890104*
6	152	890056*	890106*
8	203	890058*	890108*
10	254	890060*	890110*
12	305	890062*	890112*
16	406	890066*	890116*
20	508	890070*	890120*
24	610	890074*	890124*

Substitute the asterisk (*) with the proper hole size letter from Table 1.

Table 1 Tab Hole Size

Tab Mounting Hole Diameter		
Inch	mm	Size Letter
0.131	3.3	P
0.196	4.9	Q
0.257	6.5	R
0.283 [†]	7.1 [†]	S
0.320 [†]	8.1 [†]	T
0.379 [†]	9.6 [†]	U
0.406 [†]	10.3 [†]	V
0.468 [†]	11.8 [†]	W
0.515 [†]	13.1 [†]	Y

(†) These sizes only available in stainless steel round tabs

Lanyards without Tabs

Length		2 Loops	1 Loops (Pin)
inch	mm	(Fig. 2)	(Fig. 3)
4	102	890204	890254
6	152	890206	890256
8	203	890208	890258
10	254	890210	890260
12	305	890212	890262
16	406	890216	890266
20	508	890220	890270
24	610	890224	890274

Lanyard Loop/Eyelet (Fig. 4)

For Screw Size	
#10	M5
890304	890404
890306	890406
890308	890408
890310	890410
890312	890412
890316	890416
890320	890420
890324	890424

Part Numbering: Lanyards to be Supplied Separately

For lanyards with tabs, ordered separately without pins (photo page 26), specify the six digit pin number followed by the hole size letter from Table 1.

Example D: For a 24" (610 mm) lanyard with stainless steel round tab with a mounting hole diameter of 0.406" (10.3 mm), the part number is 890074V.



Kwik-Lok® Pin Specifications

Kwik-Lok® Pin Specifications – Inch

Pin Dia (in)	Double Shear Resistance Minimum (lbs)*	2 Ball Locking Element Tensile Strength Min (lbs)†	Recommended Hole Diameter (in)	
	Stainless Steel 17-4 PH Heat Treated		Max	Min
3/16 (#10)	5,150	200	0.1940	0.1900
1/4	9,200	230	0.2540	0.2500
5/16	14,400	510	0.3165	0.3125
3/8	20,700	575	0.3790	0.3750
7/16	28,500	710	0.4425	0.4375
1/2	36,900	1,160	0.5050	0.5000
9/16	46,700	1,420	0.5675	0.5625
5/8	57,800	2,070	0.6300	0.6250
3/4	83,200	2,950	0.7570	0.7500
7/8	112,500	3,900	0.8820	0.8750
1	147,200	5,480	1.0100	1.0000

Kwik-Lok® Pin Specifications – Metric

Pin Dia (mm)	Double Shear Resistance Minimum (kN)*	2 Ball Locking Element Tensile Strength Min (N)†	Recommended Hole Diameter (mm)	
	Stainless Steel 17-4 PH Heat Treated		Max	Min
5	24	890	5.1	5
6	35	890	6.1	6
8	65	2,250	8.1	8
10	100	2,280	10.1	10
12	144	3,150	12.1	12
16	257	9,200	16.1	16
20	403	13,100	20.15	20
25	631	23,400	25.15	25

* Double shear values are the minimum requirements according to NAS functionality tests.

† Locking element tensile strength values are the minimum requirements of NAS functionality tests. Pins may be special ordered with 4 locking balls for additional locking element tensile strength.

Military Specifications (MS) & National Aerospace Standards (NASM)

Jergens is a Department of Defense approved supplier of Quick Release Pins, under CAGE code 94882. Certificate of Conformance is available upon request at time of order. DFARS compliant material can be quoted upon request.

NAS Number 1333-1346 and 1353-1366 are available.

MS Numbers 17984-90 now refer to NASM 17984-17990.

MS 17984 C 4 15

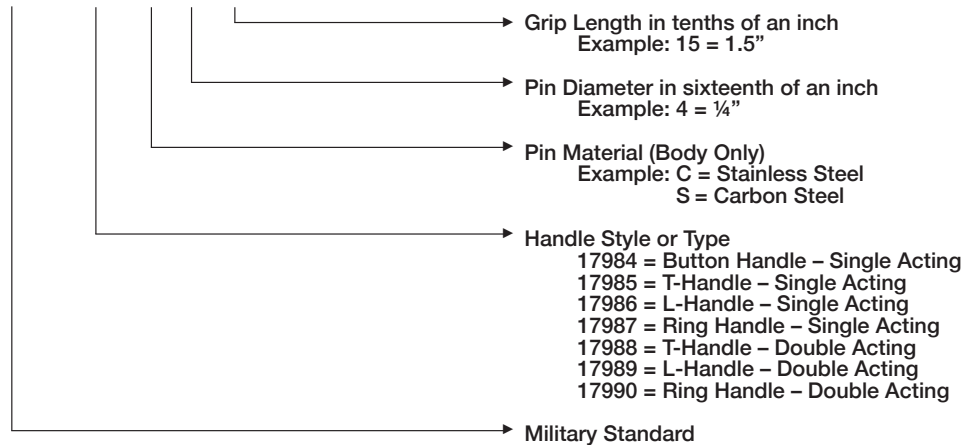

Special Military and Aerospace size and configurations are available. Please contact customer service 1-866-KWIK-LOK (594-5565).



Material Specifications

Kwik-Lok® Pin

Component Part	Material
Bodies (Shank)	CRES 17-4 PH Stainless Steel
Balls	CRES 440C Stainless Steel*
Buttons	CRES 17-4 PH Stainless Steel Aluminum Alloy 2024
Springs	CRES 302 Stainless Steel
Handles	
T & L Handles	Aluminum (380) Casting
Button Handles	Aluminum Alloy 2024
Ring Handles	CRES 303 Stainless Steel
Heavy Duty T & L	CRES 303 Stainless Steel
Heavy Duty Button Handle	CRES 303 Stainless Steel
Recessed Button Handle	CRES 300 Series Stainless Steel
Collar	CRES 303 or 304 Stainless Steel

Kwik-Lok® Lifting Pin

Component Part	Material
Bodies (Shank)	CRES 17-4 PH Heat Treated Stainless Steel
Balls	CRES 440C Stainless Steel*
Buttons	CRES 303 Stainless Steel
Lift Ring	Forged 17-4 PH Stainless Steel
Springs	CRES 302 Stainless Steel

Detent Pins

Component Part	Material
Bodies (Shank)	CRES 17-4 PH Stainless Steel
Balls	CRES 440C Stainless Steel*
Springs	CRES 302 Stainless Steel
Head	CRES 303 Stainless Steel

* Actual locking element tensile strength is reduced by lower strength alloys.
Ordering special pins with 4 balls will increase locking element tensile strength above NAS functionality test requirements.

Heat Treatment:

- 17-4 PH Stainless Steel: Condition H-900, Rockwell C40 Min per MIL-H-6875

Surface Treatment:

- CRES Parts: Passivate per AMS-QQ-P-35
- Aluminum Alloy Parts: Anodize per MIL-A-8625 Type I or II per MIL-C-5541 Class 1A
- Aluminum Handles: Color Black

Jergens Kwik-Lok® Pins are designed and manufactured to meet or exceed these standards.



Kwik-Lok® Pin Special Application Information

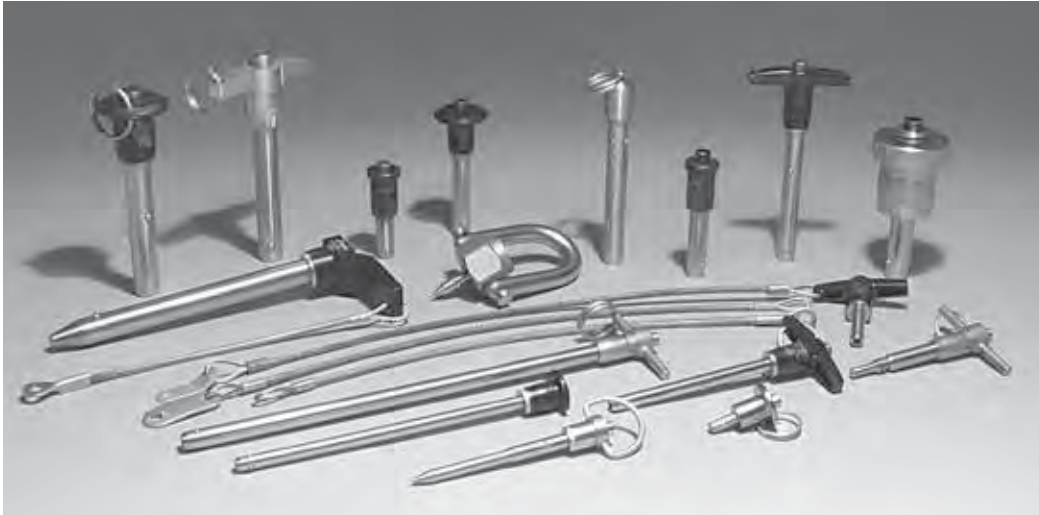

Special Kwik-Lok® Pins

If you don't see the exact Kwik-Lok® Pin to meet your application requirements, photocopy the form below, indicate your requirements, and send to Jergens.

Quotation Request Worksheet (online at www.jergensinc.com/tools/pins_rfq.aspx)

		<p>1. Pin Diameter _____</p> <p>2. Grip Length _____</p> <p>3. Overall Length _____</p>
--	--	---

*For special Shank/Lanyard configurations – Please provide drawing or sketch.

Application (describe): _____

Handle Style: T L Ring Button Recessed Button Kwik-Lok® Lifting Pins Special _____

Body Material: 17-4 PH heat treated Stainless Steel Other (describe) _____

Number of Locking Elements: 2 balls(standard) 4 balls Attach Split Ring? _____ (yes/no)

*Lanyard Length: _____ (inch or mm) SS cable with nylon color _____ (Green,Black,Clear or other)

Attach Lanyard directly to Pin without split ring? _____ (yes/no) Attach to Split Ring? _____ (yes/no)

Tabs: Round (Stainless Steel) Oval (Aluminum) Mounting Hole Size _____ (inch or mm)

Loop/Eyelet (Stainless Steel) with Mounting Hole: 0.19" for #10 screw 5.2mm for M5 screw

Quantity Required: _____ (pieces) Request date: _____ Annual Requirements _____ (pieces)

NAME: _____ POSITION/TITLE: _____

COMPANY: _____ ADDRESS: _____

CITY: _____ STATE: _____ COUNTRY: _____ POSTAL CODE: _____

TELEPHONE: _____ FAX: _____ E-MAIL: _____

KWIK-LOK® PINS

SPRING LOADED DEVICES

Spring Loaded Devices

Plungers:

Ball Plungers.....	39
Ball Plungers, Metric.....	40
Ball Plungers, Stainless Steel.....	40
Plungers, Hand Retractable Style	42
Plungers, L Handle Hand Retractable Locking	44
Plungers, Press Fit	40
Plungers, Pull Ring Retractable	43
Plungers, Shortie Spring	37
Plungers, Shortie Spring Stainless Steel	37
Plungers, Shortie Spring, Metric	37
Plungers, Special Spring and Ball.....	41
Plungers, Spring	33-38
Plungers, Spring, Metric.....	35-36
Plunger Wrenches	38



Jergens Spring & Ball Plungers Last Longer

...And Here's Why!

Spring Plungers

Spring Plunger tips are manufactured using case hardened steel. This means they have a protective shell, about .10" deep.

Jergens Spring and Ball Plungers have accurate end forces, are easy to install, and are competitively priced. They are manufactured in the U.S.A. in a ISO 9001:2015 certified quality system.

And if these aren't enough reasons to specify Jergens Spring and Ball Plungers, here are a few more:

Better Point of Contact

The Jergens plungers are turned and the tips generated in one smooth continuing process. This results in a constant radius tip, perfectly tangent to the point where the tip joins the shaft. Conventional two step, turn and grind operations, can leave ridges on the shaft at the tip junction and can also produce out-of-round tips. These, in turn, can gouge or score finely finished parts or can cause detent cams to hang up or stick.

Extra Length Springs for Longer Life

The longer the spring, the longer its life. Jergens goes to extra lengths to minimize the thickness of the base flanges on all of its plungers. That allows us to use longer springs with less chance for fatigue and breakage.

Improved Plunger to Body Alignment

The long base flange allows for a larger bearing surface. This means improved plunger-to-body alignment, truer travel, and much improved side load characteristics.

Tighter Fit Resists Contamination

Closer machining tolerances, minimum plunger-to-body clearance, and smoother plunger finish make Jergens plungers fit more snugly in the plunger bore. This improves plunger alignment and provides extra resistance to contaminant entry. The results: dirt and grit cannot get to the bearing surfaces to shorten the life of the plunger.

Better Plunger Adjustment

The Solid Drive Design assures that during removal or adjustment of the plunger, the whole plunger is moving, not just the set screw. This means no lost parts or springs falling out of the plunger.

Ball Plungers

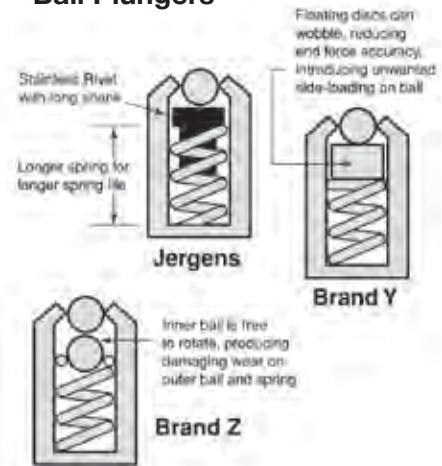

Positive Control of Spring Pressure

Accurate spring alignment is maintained by using a stainless rivet with a long shank on larger sizes of Jergens Ball Plungers. This precisely positions the spring for more accurate ball travel and provides positive control of spring pressure. Conventional floating discs are easily misaligned, while the rotation of the inner ball on dual-ball plungers results in less wearability on both the spring and the ball.

Longer Spring Life

By minimizing the lining pin head thickness, Jergens is able to use the longest possible springs. This, of course, means less fatigue and longer spring life.

Uniform Ball Projection

The distance by which the ball projects from the body of the plunger must be uniform from plunger to plunger. This uniformity is maintained by precisely controlling the crimping pressure applied to the neck of the plunger. Accurate machine controls plus rigid inspection procedures keep variances in ball projection to within $\pm .005"$.

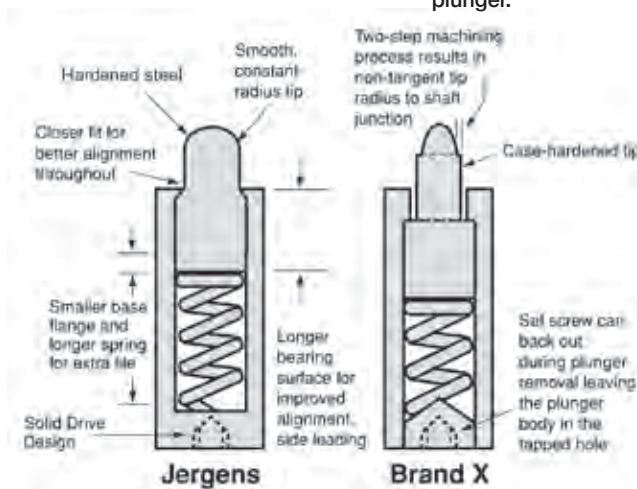



Spring Plungers Inch



- Single unit construction
- No set screw to separate from plunger body
- Better reliability
- Steel tips are case hardened steel
- Close tolerance between tip and body

- Material: Body – Low Carbon Steel, Black Oxide or 303-Stainless Steel
Tip – Steel or Stainless Steel

- Thread: 2A-UNC
- 3D Solid Models are available in multiple formats from www.jergensinc.com
- Conforms to TCMA dimensional standards
- Patch-Style locking element

Plunger tips are color coded to indicate light or heavy force:
 Silver = Steel Tip, Light Force
 Black = Steel Tip, Heavy Force

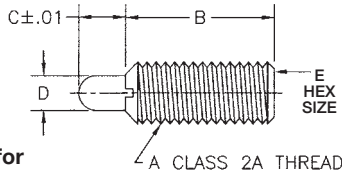

Hex drive in rear for spring plunger insertion.

Unlike conventional spring plungers, the body of a Jergens Solid Drive Plunger is machined in one piece. The spring is assembled from the top so that there is no need for a set screw. Solid Drive Plungers do not have a set screw which can loosen or separate from the plunger body. The advantage is no lost springs, no need for “easy-out” tools. When adjusting Solid Drive, you can be sure the plunger body is turning and not a set screw.

Specials available, see page 41 for Plunger Quote Request worksheet.

Inch – Steel & Stainless Steel Tip With Locking Element

SS Part Number	Steel Part Number	Thread Size A	Initial Force (lbs)	Final Force (lbs)	B	C	D	Hex Size E
27336	27321	6-32	0.5	1.5	17/32	1/16	0.046	3/64
26936	26921	6-32	1.5	4.5	17/32	1/16	0.046	3/64
27337	27322	8-32	0.7	2.3	5/8	3/32	0.070	5/64
26937	26922	8-32	2.7	7.3	5/8	3/32	0.070	5/64
27338	27323	10-32	1.3	2.7	3/4	1/8	0.093	3/32
26938	26923	10-32	2.9	11.1	3/4	1/8	0.093	3/32
27339	27324	1/4-20	1.0	4.0	1	3/16	0.119	1/8
26939	26924	1/4-20	3.0	13.0	1	3/16	0.119	1/8
27340	27325	1/4-28	1.0	4.0	1	3/16	0.119	1/8
26940	26925	1/4-28	3.0	13.0	1	3/16	0.119	1/8
27341	27326	5/16-18	1.5	4.5	1	3/16	0.135	5/32
26941	26926	5/16-18	3.0	15.0	1	3/16	0.135	5/32
27342	27327	3/8-16	2.8	7.2	1 1/8	3/16	0.186	3/16
26942	26927	3/8-16	5.5	14.5	1 1/8	3/16	0.186	3/16
27343	27328	1/2-13	2.7	9.3	1 1/4	1/4	0.248	1/4
26943	26928	1/2-13	6.6	17.4	1 1/4	1/4	0.248	1/4
27344	27329	5/8-11	3.5	10.5	1 1/2	5/16	0.310	5/16
26944	26929	5/8-11	10.5	25.5	1 1/2	5/16	0.310	5/16
27345	27330	3/4-10	5.5	14.5	1 3/4	5/16	0.374	3/8
26945	26930	3/4-10	6.7	37.3	1 3/4	5/16	0.374	3/8
—	27311*	1-8	10.0	25.0	2 13/32	1/2	0.499	3/8
—	26911*	1-8	16.0	68.0	2 13/32	1/2	0.499	3/8

Without Locking Element

SS Part Number	Steel Part Number
27031	27221
27011	26821
27032	27222
27012	26822
27033	27223
27013	26823
27034	27224
27014	26824
27035	27225
27015	26825
27036	27226
27016	26826
27037	27227
27017	26827
27038	27228
27018	26828
27039	27229
27019	26829
27040	27230
27020	26830
—	27211*
—	26811*

* Not available in DRIVE construction.

NOTE: For easy insertion of Spring Plungers with locking elements, the tapped hole should be countersunk at least .030-.045" (0.76-1.14mm) larger than the major diameter of the plunger.

Special materials and sizes available upon requests.



Spring Plungers Inch



- Single unit construction
- No set screw to separate from plunger body
- No need for “easy-out” tools
- Better reliability
- Steel tips are case hardened steel
- Close tolerance between tip and body

- Material: Body – Low Carbon Steel, Black Oxide or 303-Stainless Steel

Tip – Delrin

- Thread: 2A-UNC
- 3D Solid Models are available in multiple formats from www.jergensinc.com
- Conforms to TCMA dimensional standards
- Patch-Style locking element

Plunger tips are color coded to indicate light or heavy force:

- White = Delrin Tip, Light Force
- Blue = Delrin Tip, Heavy Force

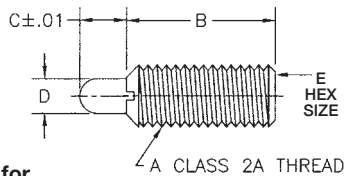

Hex drive in rear for spring plunger insertion.

Unlike conventional spring plungers, the body of a Jergens Solid Drive Plunger is machined in one piece. The spring is assembled from the top so that there is no need for a set screw. Solid Drive Plungers do not have a set screw which can loosen or separate from the plunger body. The advantage is no lost springs, no need for “easy-out” tools. When adjusting Solid Drive, you can be sure the plunger body is turning and not a set screw.

Specials available, see page 41 for Plunger Quote Request worksheet.

Inch – Delrin Tip With Locking Element

SS Part Number	Steel Part Number	Thread Size A	Initial Force (lbs)	Final Force (lbs)	B	C	D	Hex Size E
30936	30921	6-32	0.5	1.5	17/32	1/16	0.046	3/64
30536	30521	6-32	1.5	4.5	17/32	1/16	0.046	3/64
30937	30922	8-32	0.7	2.3	5/8	3/32	0.070	5/64
30537	30522	8-32	2.7	7.3	5/8	3/32	0.070	5/64
30938	30923	10-32	1.3	2.7	3/4	1/8	0.093	3/32
30538	30523	10-32	2.9	11.1	3/4	1/8	0.093	3/32
30939	30924	1/4-20	1.0	4.0	1	3/16	0.119	1/8
30539	30524	1/4-20	3.0	13.0	1	3/16	0.119	1/8
30940	30925	1/4-28	1.0	4.0	1	3/16	0.119	1/8
30540	30525	1/4-28	3.0	13.0	1	3/16	0.119	1/8
30941	30926	5/16-18	1.5	4.5	1	3/16	0.135	5/32
30541	30526	5/16-18	3.0	15.0	1	3/16	0.135	5/32
30942	30927	3/8-16	2.8	7.2	1 1/8	3/16	0.186	3/16
30542	30527	3/8-16	5.5	14.5	1 1/8	3/16	0.186	3/16
30943	30928	1/2-13	2.7	9.3	1 1/4	1/4	0.248	1/4
30543	30528	1/2-13	6.6	17.4	1 1/4	1/4	0.248	1/4
30944	30929	5/8-11	3.5	10.5	1 1/2	5/16	0.310	5/16
30544	30529	5/8-11	10.5	25.5	1 1/2	5/16	0.310	5/16
30945	—	3/4-10	5.5	14.5	1 3/4	5/16	0.374	3/8
30545	—	3/4-10	6.7	37.3	1 3/4	5/16	0.374	3/8

Without Locking Element

SS Part Number	Steel Part Number
30510	30821
30500	30421
30511	30822
30501	30422
30512	30823
30502	30423
30513	30824
30503	30424
30514	30825
30504	30425
30515	30826
30505	30426
30516	30827
30506	30427
30517	30828
30507	30428
30518	30829
30508	30429
30519	—
30509	—

NOTE: For easy insertion of Spring Plungers with locking elements, the tapped hole should be countersunk at least .030-.045" (0.76-1.14mm) larger than the major diameter of the plunger.

Special materials and sizes available upon requests.



Spring Plungers Metric

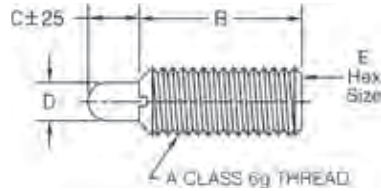

The hex drive in the rear of the spring plunger is for plunger insertion.

Specials available, see page 41 for Plunger Quote Request worksheet.

- Material: Body – Low Carbon Steel, Black Oxide or 303-Stainless Steel
Tip – Steel or Stainless Steel
- Thread: 2A-UNC
- 3D Solid Models are available in multiple formats from www.jergensinc.com
- Conforms to TCMA dimensional standards
- Patch-Style locking element

Unlike conventional spring plungers, the body of a Jergens Solid Drive Plunger is machined in one piece. The spring is assembled from the top so that there is no need for a set screw. Solid Drive Plungers do not have a set screw which can loosen or separate from the plunger body. The advantage is no lost springs, no need for “easy-out” tools. When adjusting Solid Drive, you can be sure the plunger body is turning and not a set screw.

Metric – Steel & Stainless Steel Tip With Locking Element

SS Part Number	Steel Part Number	Thread Size A	Initial Force (kg)	Final Force (kg)	B	C	D	Hex Size E
30890	27250	M4 x 0.7	0.32	1.04	16	2.5	1.78	2.0
30490	26850	M4 x 0.7	1.22	3.29	16	2.5	1.78	2.0
30891	27251	M5 x 0.8	0.59	1.22	19	3.0	2.36	2.5
30491	26851	M5 x 0.8	1.31	5.00	19	3.0	2.36	2.5
30892	27252	M6 x 1.0	0.45	1.80	25	5.0	3.02	3.0
30492	26852	M6 x 1.0	1.35	5.85	25	5.0	3.02	3.0
30893	27253	M8 x 1.25	0.68	2.03	25	5.0	3.43	4.0
30493	26853	M8 x 1.25	1.35	6.75	25	5.0	3.43	4.0
30894	27254	M10 x 1.5	1.26	3.26	29	5.0	4.72	5.0
30494	26854	M10 x 1.5	2.48	6.53	29	5.0	4.72	5.0
30895	27255	M12 x 1.75	1.22	4.21	32	6.0	6.30	6.0
30495	26855	M12 x 1.75	2.97	7.83	32	6.0	6.30	6.0
30897	27257	M16 x 2.0	1.58	4.76	38	8.0	7.87	8.0
30497	26857	M16 x 2.0	4.73	11.48	38	8.0	7.87	8.0
30898	27258	M20 x 2.5	2.50	6.58	44	8.0	9.50	10.0
30498	26858	M20 x 2.5	3.05	16.95	44	8.0	9.50	10.0

Without Locking Element

SS Part Number	Steel Part Number
30880	27270
30480	26870
30881	27271
30481	26871
30882	27272
30482	26872
30883	27273
30483	26873
30884	27274
30484	26874
30885	27275
30485	26875
30887	27277
30487	26877
30888	27278
30488	26878

NOTE: For easy insertion of Spring Plungers with locking elements, the tapped hole should be countersunk at least .030-.045" (0.76-1.14mm) larger than the major diameter of the plunger.

Special materials and sizes available upon requests.



Spring Plungers Metric – Delrin Tip

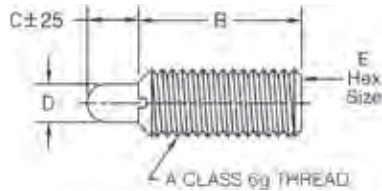

The hex drive in the rear of the spring plunger is for plunger insertion.

Specials available, see page 41 for Plunger Quote Request worksheet.

- Material: Body – Low Carbon Steel, Black Oxide
Tip – Delrin
- Thread: 2A-UNC
- 3D Solid Models are available in multiple formats from www.jergensinc.com
- Conforms to TCMA dimensional standards
- Patch-Style locking element

Unlike conventional spring plungers, the body of a Jergens Solid Drive Plunger is machined in one piece. The spring is assembled from the top so that there is no need for a set screw. Solid Drive Plungers do not have a set screw which can loosen or separate from the plunger body. The advantage is no lost springs, no need for “easy-out” tools. When adjusting Solid Drive, you can be sure the plunger body is turning and not a set screw.

Metric – Delrin Tip With Locking Element

Steel Part Number	Thread Size A	Initial Force (kg)	Final Force (kg)	B	C	D	Hex Size E	Without Locking Element Steel Part Number
30850	M4 x 0.7	0.32	1.04	16	2.5	1.78	2.0	30870
30450	M4 x 0.7	1.22	3.29	16	2.5	1.78	2.0	30470
30851	M5 x 0.8	0.59	1.22	19	3.0	2.36	2.5	30871
30451	M5 x 0.8	1.31	5.00	19	3.0	2.36	2.5	30471
30852	M6 x 1.0	0.45	1.80	25	5.0	3.02	3.0	30872
30452	M6 x 1.0	1.35	5.85	25	5.0	3.02	3.0	30472
30853	M8 x 1.25	0.68	2.03	25	5.0	3.43	4.0	30873
30453	M8 x 1.25	1.35	6.75	25	5.0	3.43	4.0	30473
30854	M10 x 1.5	1.26	3.26	29	5.0	4.72	5.0	30874
30454	M10 x 1.5	2.48	6.53	29	5.0	4.72	5.0	30474
30855	M12 x 1.75	1.22	4.21	32	6.0	6.30	6.0	30875
30455	M12 x 1.75	2.97	7.83	32	6.0	6.30	6.0	30475
30857	M16 x 2.0	1.58	4.76	38	8.0	7.87	8.0	30877
30457	M16 x 2.0	4.73	11.48	38	8.0	7.87	8.0	30477
30858	M20 x 2.5	2.50	6.58	44	8.0	9.50	10.0	30878
30458	M20 x 2.5	3.05	16.95	44	8.0	9.50	10.0	30478

NOTE: For easy insertion of Spring Plungers with locking elements, the tapped hole should be countersunk at least .030-.045" (0.76-1.14mm) larger than the major diameter of the plunger.

Special materials and sizes available upon requests.



Shortie Spring Plungers Inch



- Material: Body – Low Carbon Steel, Black Oxide
Tip – Delrin or Steel
- Thread: 2A-UNC
- 3D Solid Models are available in multiple formats from www.jergensinc.com
- Conforms to TCMA dimensional standards
- Patch-Style locking element
- Thread: 2A-UNC
- Available in metric sizes. See page 38.

Jergens Feature:

Jergens Shortie Spring Plungers are made to the same quality standards as the Solid Drive
*Made with full standard spring plunger stroke in a short body. A screwdriver slot is substituted for the hex drive due to the smaller size.

Inch – Shortie Spring Plunger With Locking Element

Without Locking Element

Steel Tip	Delrin Tip	Thread Size A	Initial Force (lbs)	Final Force (lbs)	B	C	D	Steel Tip	Delrin Tip
27101	30701	6-32	0.5	1.5	3/8	1/16	0.046	27001	30601
26701	30301	6-32	0.5	3.5	3/8	1/16	0.046	26601	30201
27102	30702	8-32	0.5	2.0	1/2	3/32	0.070	27002	30602
26702	30302	8-32	0.5	4.0	1/2	3/32	0.070	26602	30202
27103*	30703*	10-32	0.3	3.0	9/16	1/8	0.093	27003*	30603*
26703*	30303*	10-32	0.5	5.0	9/16	1/8	0.093	26603*	30203*
27104	30704	1/4-20	0.3	3.5	5/8	3/16	0.119	27004	30604
26704	30304	1/4-20	0.5	6.0	5/8	3/16	0.119	26604	30204
27105	30705	5/16-18	0.5	4.5	5/8	3/16	0.135	27005	30605
26705	30305	5/16-18	0.5	10.0	5/8	3/16	0.135	26605	30205
27106	30706	3/8-16	1.5	7.5	11/16	3/16	0.186	27006	30606
26706	30306	3/8-16	1.0	12.0	11/16	3/16	0.186	26606	30206
27107	30707	1/2-13	1.7	8.5	13/16	1/4	0.248	27007	30607
26707	30307	1/2-13	2.5	15.0	13/16	1/4	0.248	26607	30207
27108	30708	5/8-11	2.0	10.5	1 1/8	5/16	0.310	27008	30608
26708	30308	5/8-11	3.5	26.0	1 1/8	5/16	0.310	26608	30208

*Thread: UNF

Shortie Spring Plungers Stainless Steel (Short Travel)

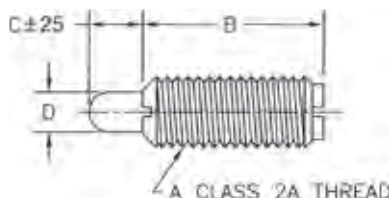

The slot in the rear of the Shortie Spring Plunger is for insertion.

- Material:
Body, 303 Stainless
Spring, 303 Stainless
Nose, Stainless or Delrin
- Thread: 2A-UNC

Inch – Stainless Steel With Locking Element

Part Number		Thread Size A	Force, lbs.		B	C	D
Stainless Tip	Delrin Tip		Initial	Final			
27601	27621	8-32	.5	1.5	7/16	.052	.070
27602	27622	8-32	1.5	4.75	7/16	.052	.070
27603*	27623*	8-36	.5	1.5	7/16	.052	.070
27604*	27624*	8-36	1.5	4.75	7/16	.052	.070
27605	27625	10-32	.75	2.5	15/32	.065	.093
27606	27626	10-32	1.75	6.25	15/32	.065	.093
27607	27627	1/4-20	1.0	3.5	17/32	.078	.119
27608	27628	1/4-20	3.0	10.5	17/32	.078	.119
27609	27629	5/16-18	1.0	4.0	9/16	.084	.135
27610	27630	5/16-18	3.75	15.5	9/16	.084	.135
27611	27631	3/8-16	1.5	5.0	5/8	.110	.186
27612	27632	3/8-16	4.5	18.5	5/8	.110	.186
27613	27633	1/2-13	1.75	5.5	3/4	.151	.248
27614	27634	1/2-13	5.0	28.0	3/4	.151	.248

*Thread: UNF

Specials available, see page 41 for Plunger Quote Request worksheet.

Special materials and sizes available upon requests.



Shortie Spring Plungers Metric

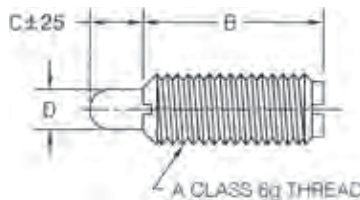

Specials available, see page 41 for Plunger Quote Request worksheet.

- Material: Body – Low Carbon Steel, Black Oxide
Tip – Delrin or Steel
- Thread: Class 6g
- 3D Solid Models are available in multiple formats from www.jergensinc.com
- Patch-Style locking element

Plunger Tips are color coded to indicate light or heavy force.

- White = Light Force
- Blue = Heavy Force

Jergens Feature:

Jergens Shortie Spring Plungers are made to the same quality standards as the Solid Drive
*Made with full standard spring plunger stroke in a short body. A screwdriver slot is substituted for the hex drive due to the smaller size.

*Carbon Steel body only

Metric – Shortie Spring Plungers With Locking Elements

Steel Tip	Delrin Tip	Thread Size A	Initial Force (kg)	Final Force (kg)	B	C	D
27170	30770	M4 x 0.7	0.23	0.91	13.0	2.5	1.78
26770	30370	M4 x 0.7	0.23	1.81	13.0	2.5	1.78
27171	30771	M5 x 0.8	0.14	1.36	14.5	3.0	2.36
26771	30371	M5 x 0.8	0.23	2.27	14.5	3.0	2.36
27172	30772	M6 x 1.0	0.14	1.59	16.0	4.7	3.02
26772	30372	M6 x 1.0	0.23	2.72	16.0	4.0	3.02
27173	30773	M8 x 1.25	0.23	2.04	16.0	5.0	3.43
26773	30373	M8 x 1.25	0.23	4.54	16.0	5.0	3.43
27174	30774	M10 x 1.5	0.68	3.4	17.5	4.7	4.72
26774	30374	M10 x 1.5	0.46	5.44	17.5	5.0	4.72
27175	30775	M12 x 1.75	0.77	3.86	20.5	6.5	6.30
26775	30375	M12 x 1.75	1.13	6.80	20.5	6.5	6.30
27177	30777	M16 x 2.0	0.91	4.76	28.5	8.0	7.87
26777	30377	M16 x 2.0	1.59	11.79	28.5	8.0	7.87

Special materials and sizes available upon requests.

Plunger Wrenches



IMPORTANT: It is not recommended that a screwdriver be used to insert ball or spring plungers from the ball or plunger end. The tip of the screwdriver will force the ball or tip of the plunger below the surface of the end of the plunger. This may compress the spring to a solid, causing possible damage to the spring plunger. It is recommended that a Jergens Plunger Wrench be used or that a slot be ground in the end of a screwdriver to clear the height of the ball or tip for each size ball or plunger used.

Part Number	Thread Size of Plungers	
	Inch	Metric
27501	6-32	—
27502	8-32	M4
27503	10-32	M5
27504	1/4-20	M6
27505	5/16-18	M8
27506	3/8-16	M10
27507	1/2-13	M12
27508	5/8-11	M16
27509	3/4-10	M20
27510	1-8	M25



Ball Plungers

Inch

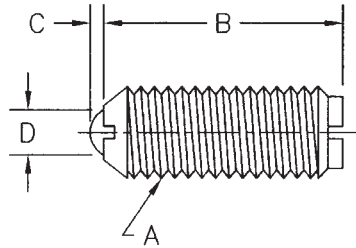

- Patch-Style locking element
- Body Material: Low Carbon Steel, or 303 Stainless Steel
- Ball Material: Stainless, 440
- Spring Material: Stainless, 17-7 PH
- Finish: Black Oxide on Body
- Thread: 2A
- Dimensionally conforms to TCMA standards
- 3D Solid Models are available in multiple formats from www.jergensinc.com

Inch – Coarse Thread (UNC) With Locking Element

SS Part Number	Steel Part Number	Thread Size A	Initial Force (lbs)	Final Force (lbs)	B	C	D
11102	10927	5-40	0.25	0.75	1/4	0.020	0.062
11201	10701	10-24	0.50	1.50	33/64	0.025	0.093
11211	10711	10-24	1.50	3.00	33/64	0.025	0.093
11202	10702	10-24	2.00	5.00	33/64	0.025	0.093
11108	10904	1/4-20	2.00	4.00	17/32	0.035	0.125
11109	10905	1/4-20	3.00	7.00	17/32	0.035	0.125
11110	10906	1/4-20	4.00	12.00	17/32	0.035	0.125
11111	10907	5/16-18	2.00	4.50	37/64	0.040	0.156
11112	10908	5/16-18	4.00	9.00	37/64	0.040	0.156
11113	10909	5/16-18	6.00	17.00	37/64	0.040	0.156
11114	10910	3/8-16	2.50	5.00	5/8	0.048	0.187
11115	10911	3/8-16	5.00	10.00	5/8	0.048	0.187
11116	10912	3/8-16	6.00	21.00	5/8	0.048	0.187
11117	10913	1/2-13	3.00	6.00	3/4	0.072	0.281
11118	10914	1/2-13	6.00	12.00	3/4	0.072	0.281
11119	10915	1/2-13	6.00	30.00	3/4	0.072	0.281
11120	10916	5/8-11	4.50	9.00	1	0.096	0.375
11121	10917	5/8-11	9.00	18.00	1	0.096	0.375
11122	10918	5/8-11	7.00	50.00	1	0.096	0.375

Without Locking Element

SS Part Number	Steel Part Number
11002	10827
11221	10721
11231	10731
11222	10722
11008	10804
11009	10805
11010	10806
11011	10807
11012	10808
11013	10809
11014	10810
11015	10811
11016	10812
11017	10813
11018	10814
11019	10815
11020	10816
11021	10817
11022	10818

NOTE: For easy insertion of Ball Plungers with locking elements, the tapped hole should be countersunk at least .030-.045 (0.76-1.14mm) larger than the major diameter of the plunger.

Inch – Fine Thread (UNF) With Locking Element

SS Part Number	Steel Part Number	Thread Size A	Initial Force (lbs)	Final Force (lbs)	B	C	D
11101	10926	4-48	0.12	0.50	3/16	0.020	0.062
11103	10928	6-40	0.50	1.00	5/16	0.023	0.078
11104	10929	8-36	0.50	1.25	11/32	0.025	0.093
11105	10901	10-32	0.50	1.50	33/64	0.025	0.093
11106	10902	10-32	1.50	3.00	33/64	0.025	0.093
11107	10903	10-32	2.00	5.00	33/64	0.025	0.093
11203	10703	1/4-28	2.0	4.0	17/32	0.035	0.125
11212	10712	1/4-28	3.0	7.0	17/32	0.035	0.125
11204	10704	1/4-28	4.0	12.0	17/32	0.035	0.125
11205	10705	5/16-24	2.0	4.5	37/64	0.040	0.156
11213	10713	5/16-24	4.0	9.0	37/64	0.040	0.156
11206	10706	5/16-24	6.0	17.0	37/64	0.040	0.156
11207	10707	3/8-24	2.5	5.0	5/8	0.048	0.187
11214	10714	3/8-24	5.0	10.0	5/8	0.048	0.187
11208	10708	3/8-24	6.0	21.0	5/8	0.048	0.187
11209	10709	1/2-20	3.0	6.0	3/4	0.072	0.281
11215	10715	1/2-20	6.0	12.0	3/4	0.072	0.281
11210	10710	1/2-20	6.0	30.0	3/4	0.072	0.281

Without Locking Element

SS Part Number	Steel Part Number
11001	10826
11003	10828
11004	10829
11005	10801
11006	10802
11007	10803
11223	10723
11232	10732
11224	10724
11225	10725
11233	10733
11226	10726
11227	10727
11234	10734
11228	10728
11229	10729
11235	10735
11230	10730

Special materials and sizes available upon requests.



Ball Plungers

Metric

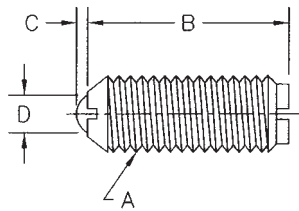

- Body Materials: Low Carbon Steel, Black Oxide or 303 Stainless Steel
- Ball: Stainless, 440
- Spring: Stainless, 17-7 PH
- Thread: Class 6g
- 3D Solid Models are available in multiple formats from www.jergensinc.com
- Patch-Style locking element

NOTE: For easy insertion of Ball Plungers with locking elements, the tapped hole should be countersunk at least .030-.045 (0.76-1.14mm) larger than the major diameter of the plunger.

Metric – Steel & SS Tip With Locking Element

SS Part Number	Steel Part Number	Thread Size A	Initial Force (kg)	Final Force (kg)	B	C	D
11051	10971	M4 x 0.7	0.23	0.56	9.00	0.60	2.38
11052	10972	M5 x 0.8	0.23	0.68	13.00	0.60	2.38
11053	10973	M5 x 0.8	0.68	1.35	13.00	0.60	2.38
11054	10974	M5 x 0.8	0.90	2.25	13.00	0.60	2.38
11055	10975	M6 x 1.0	0.90	1.80	13.50	0.90	3.18
11056	10976	M6 x 1.0	1.35	3.15	13.50	0.90	3.18
11057	10977	M6 x 1.0	1.80	5.40	13.50	0.90	3.18
11058	10978	M8 x1.25	0.90	2.03	15.00	1.00	3.97
11059	10979	M8 x1.25	1.80	4.05	15.00	1.00	3.97
11060	10980	M8 x1.25	2.70	7.65	15.00	1.00	3.97
11061	10981	M10 x 1.5	1.13	2.25	16.00	1.20	4.76
11062	10982	M10 x 1.5	2.25	4.50	16.00	1.20	4.76
11063	10983	M10 x 1.5	2.70	9.45	16.00	1.20	4.76
11064	10984	M12 x 1.75	1.35	2.70	19.00	2.00	7.14
11065	10985	M12 x 1.75	2.70	5.40	19.00	2.00	7.14
11066	10986	M12 x 1.75	2.70	13.50	19.00	2.00	7.14
11067	10987	M16 x 2.0	2.00	4.00	25.40	2.40	9.50
11068	10988	M16 x 2.0	4.00	8.10	25.40	2.40	9.50
11069	10989	M16 x 2.0	3.10	22.70	25.40	2.40	9.50

Without Locking Element

SS Part Number	Steel Part Number
10951	10871
10952	10872
10953	10873
10954	10874
10955	10875
10956	10876
10957	10877
10958	10878
10959	10879
10960	10880
10961	10881
10962	10882
10963	10883
10964	10884
10965	10885
10966	10886
10967	10887
10968	10888
10969	10889

Press Fit Plungers

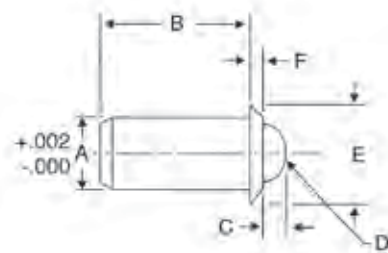

- Body Material: Low Carbon Steel
- Ball Material: Stainless, 400
- Spring Material: 17-7 PH
- Finish: Black Oxide on Body

Heavy Force

Part Number	Stainless Steel Part Number	Force (lbs)		A	B	C	Ball Dia. D	E	F
		Initial	Final						
10832	11032	2	5	.188	.405	.058	.156	.250	.035
10834	11034	3	7	.250	.481	.070	.187	.312	.044
10836	11036	5	14	.375	.785	.110	.312	.500	.078
10838	11038	8	18	.500	1.130	.161	.437	.688	.088

Light Force

Part Number	Stainless Steel Part Number	Force (lbs)		A	B	C	Ball Dia. D	E	F
		Initial	Final						
10831	11031	1	2.5	.188	.405	.058	.156	.250	.035
10833	11033	1.5	3.5	.250	.481	.070	.187	.312	.044
10835	11035	2.5	7	.375	.785	.110	.312	.500	.078
10837	11037	4	9	.500	1.130	.161	.437	.688	.088

Special materials and sizes available upon requests.



Special Spring and Ball Plungers

If you don't see the exact spring or ball plunger to meet your application requirements, photocopy the form below, indicate your requirements, and mail to your Jergens Distributor or e-mail Jergens Specialty Fasteners at fasteners@jergensinc.com.

PLUNGER QUOTATION REQUEST WORKSHEET

<p>BALL</p> <p>SHORTIE</p> <p>SPRING</p>	<p>A dim. (See note below) _____ C dim. _____ B dim. _____ D dim. _____</p>
---	--

Application (describe): _____

Type of Plunger: Solid Drive Spring "Shortie" Ball Other (see sketch)

Thread or O.D. _____ (Class 2A Threads unless Otherwise Specified)

Length of Plunger Travel: _____

Initial Force Required: _____ Final Force Required: _____

Plastic Locking Patch: Required Not Required Tip/Ball Material: _____

Tip/Ball Finish: _____ Body Material: _____

Body Finish: _____ Spring Material: _____

Temperature Range: _____

Type of Environment (describe—corrosives, chemicals, contaminants, etc.): _____

Other Specifications: _____

Quantity Needed: _____ Delivery By: _____

NAME: _____ TITLE: _____

COMPANY: _____ ADDRESS: _____

CITY: _____ STATE: _____ ZIP: _____

TELEPHONE: _____ FAX: _____

Special materials and sizes available upon requests.



Retractable Plungers Hand Retractable Locking Style



- Improved design allows plunger pin to be locked in fully retracted position
- Used in machining applications as positioners, loading pins or indexing devices
- Plunger pin has slight taper on end to assure easy alignment
- Zinc Plated Carbon Steel, 303 Stainless Steel
- Delrin Nose Prevents Marring of Soft Material
- Supplied with patch-style locking element only

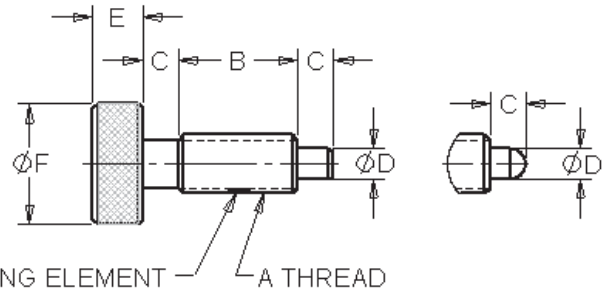

Inch – Hand Retractable Locking Style Plungers

Steel Part Number	Steel Delrin Nose Part Number	Stainless Steel Part Number	Stainless Steel Delrin Nose Part Number	A	End Force (lbs)		B	C	+.001 -.002 D	E	F	Net Wt. (lbs) 10 Pcs.
					Start	Full						
27426	27531	27826	27539	1/4-20	0.5	2.5	1/2	1/8	.124	1/4	1/2	.3
27421	27532	27821	27540	1/4-20	1.0	5.0	1/2	1/8	.124	1/4	1/2	.3
27427	27533	27827	27541	5/16-18	0.75	3.0	5/8	3/16	.155	9/32	5/8	.5
27422	27534	27822	27542	5/16-18	1.5	6.0	5/8	3/16	.155	9/32	5/8	.5
27428	27535	27828	27543	3/8-16	0.75	4.0	3/4	7/32	.186	5/16	3/4	.7
27423	27536	27823	27544	3/8-16	1.5	8.0	3/4	7/32	.186	5/16	3/4	.7
27429	27537	27829	27545	1/2-13	1.25	5.0	7/8	1/4	.249	3/8	1"	1.3
27424	27538	27824	27546	1/2-13	2.5	10.0	7/8	1/4	.249	3/8	1"	1.3

Metric – Hand Retractable Locking Style Plungers

Steel Part Number	Class 6g ISO A	End Force (kg)		B	C	+.025 -.050 D	E	F	Net Wt. (kg) 10 Pcs.
		Start	Full						
27555	M6x1.0	0.225	1.135	12.50	3.17	3	6.3	12.7	.16
27551	M6x1.0	0.4	2.27	12.50	3.17	3	6.3	12.7	.16
27556	M8x1.25	0.34	1.36	16.00	4.75	4	7.0	15.8	.27
27552	M8x1.25	0.68	2.72	16.00	4.75	4	7.0	15.8	.27
27557	M10x1.5	0.34	1.815	19.00	5.50	5	7.9	19.0	.38
27553	M10x1.5	0.68	3.63	19.00	5.50	5	7.9	19.0	.38
27558	M12x1.75	0.565	2.27	22.00	6.35	6	9.4	25.4	.7
27554	M12x1.75	1.13	4.54	22.00	6.35	6	9.4	25.4	.7

Special materials and sizes available upon requests.



Retractable Plungers Pull Ring Style



- For use in application with limited space
- Slight taper on end of plunger for easy alignment

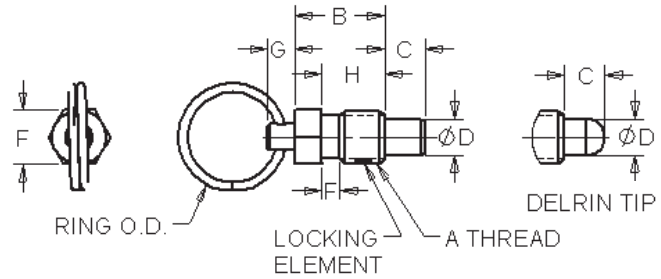

Pull Ring – Short Locking Plungers

Steel Part Number	Steel Delrin Nose Part Number	Stainless Steel Part Number	Stainless Steel Delrin Nose Part Number	A	Force, (lbs)		B	C	D	E	F	G	H	(lbs) O.D.	Net Wt. 10 Pcs.
					Initial	Final									
27441	27560	27800	27564	1/4-20	0.50	2.0	7/16	3/16	.156	1/4	1/32	5/32	9/32	3/4	.1
27442	27561	27801	27565	3/8-16	0.75	3.0	5/8	9/32	.250	3/8	1/8	3/16	7/16	3/4	.2
27443	27562	27802	27566	1/2-13	1.00	4.0	13/16	3/8	.312	1/2	5/32	1/4	9/16	1	.43
27444	27563	27803	27567	5/8-11	1.25	5.0	1	7/16	.375	5/8	5/32	5/16	11/16	1	.8



- For use in application with limited space
- Slight taper on end of plunger for easy alignment
- Turn ring to lock and extend plunger

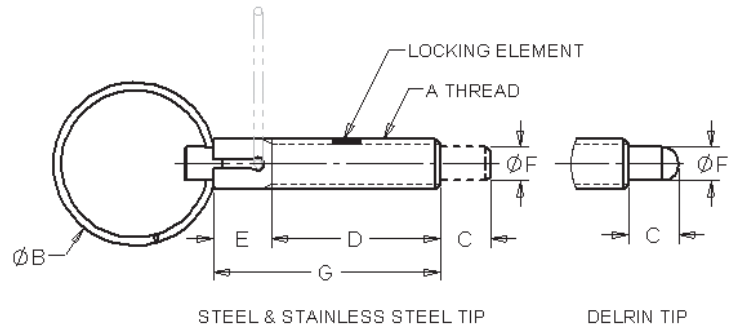

Pull Ring – Standard Length – Locking Plungers

Steel Part Number	Steel Delrin Nose Part Number	Stainless Steel Part Number	Stainless Steel Delrin Nose Part Number	A	Force, (lbs)		B	C	D	E	F	G	Net Wt. (lbs) 10 Pcs.
					Initial	Final							
27446	27568	27812	27571	1/4-20	1.0	2.5	5/8	1/4	13/16	5/16	.156	1-1/8	.15
27447	27569	27813	27572	3/8-16	2.0	4.0	1	3/8	1-1/4	7/16	.233	1-11/16	.43
27448	27570	27814	27573	1/2-13	2.5	5.0	1-1/4	1/2	1-7/16	9/16	.312	2	.9

Special materials and sizes available upon requests.
Available in patch-style locking element only



Retractable Plungers L Handle Hand Retractable Locking Style



- Hand retractable for easy removal or insertion
- Turn handle to unlock and extend plunger
- Slight taper on end of plunger for easy alignment
- Locking element standard on all sizes

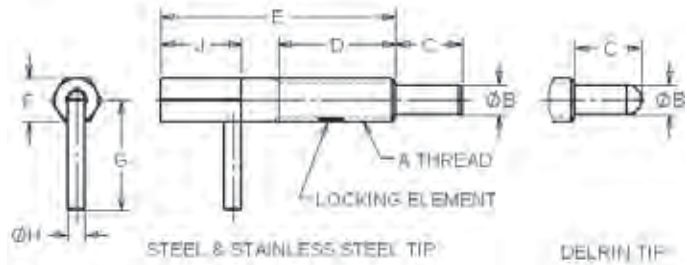

Locking Plungers – Long Reach – Standard Length

Steel Part Number	Steel Delrin Nose Part Number	Stainless Steel Part Number	Stainless Steel Delrin Nose Part Number	A	Force (lbs)		+001	B	C	D	E	F	G	H	(lbs) J	Net Wt. 10 Pcs.
					Initial	Final										
27436	27575	27836	27579	1/4-20	.50	2.5	.156	3/8	5/8	1-1/4	1/4	5/8	3/32	1/2	.15	
27437	27576	27837	27580	3/8-16	.75	3.75	.250	9/16	1-1/16	2	3/8	15/16	9/64	11/16	.53	
27438	27577	27838	27581	1/2-13	1.0	5.0	.312	3/4	1-1/8	2-1/8	1/2	1-1/4	3/16	3/4	1.03	
27439	27578	27839	27582	5/8-11	1.0	5.0	.375	1	1-3/4	3	5/8	1-5/16	3/16	1-1/16	2.23	

Locking Plungers – Long Reach – Short Length

Steel Part Number	Steel Delrin Nose Part Number	Stainless Steel Part Number	Stainless Steel Delrin Nose Part Number	A	Force (lbs)		+001	B	C	D	E	F	G	H	(lbs) J	Net Wt. 10 Pcs.
					Initial	Final										
27416	27583	27867	27587	1/4-20	.125	.50	.156	3/16	7/16	3/4	1/4	9/16	3/32	1/4	.1	
27417	27584	27868	27588	3/8-16	.25	1.25	.250	5/16	5/8	1-1/8	3/8	3/4	9/64	3/8	.3	
27418	27585	27869	27589	1/2-13	.50	2.0	.312	13/32	7/8	1-1/2	1/2	1	3/16	1/2	.7	
27419	27586	27870	27590	5/8-11	.75	2.5	.375	1/2	1-1/8	1-7/8	5/8	1-3/16	3/16	5/8	1.35	

Special materials and sizes available upon requests.
Available in patch-style locking element only

THREADED INSERTS

Threaded Inserts

Bolster Plate Bushings.....	49
Installation and Removal Instructions.....	46
Internal Locking Thread Repair Insert	52-53
Keylocking, Extra Heavy Duty Industrial Style.....	50
Keylocking, Heavy Duty Industrial Style.....	48
Keylocking, Metric/Inch	49
Keylocking, Solid Industrial Style.....	51
Keylocking, Thinwall Industrial Style.....	47
Miniature Metric Mil Spec Inserts.....	54-55
Thread Repair Kits	56-59



Installation Information



1. Drill to allow full tap depth shown in chart. Note: Tap drill is oversized; see chart below. Countersink as shown in chart.



2. Tap to depth shown in chart.



3. Install insert .010" to .030" below surface.



4. Drive keys down with proper installation tool.

Removal Information

Jergens Keylocking Inserts can be removed without damage to the parent material.

1. Drill the insert to the size and depth shown under removal data in the chart below.
2. Bend the keys down and break them off.
3. Remove the insert using an E-Z out or similar tool.



Installation Information

Preparation of External Threads Prior to Installation (For Keylocking Inserts Only)

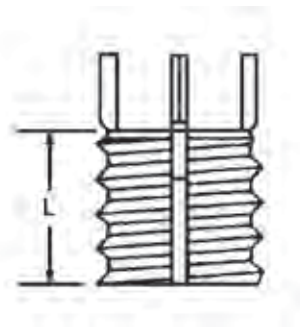

Insert		Installation Data			Removal Data	
External Thread Class 2A	Length L	Tap Drill Size	C'sink Dia. +.010 -.000	Minimum Tap Depth	Drill	
					Size	Depth
5/16-18	.31	I	.323	.37	7/32	1/8
3/8-16	.31/.37	Q	.385	.37/.43	9/32	1/8
7/16-14	.31/.37/.43	X	.447	.37/.43/.50	11/32	3/16
1/2-13	.37/.43/.50	29/64	.510	.44/.50/.56	13/32	3/16
9/16-12	.43/.50/.56	33/64	.572	.50/.56/.62	15/32	3/16
5/8-11	.50/.62	37/64	.635	.56/.68	17/32	3/16
3/4-16	.62/.81	45/64	.760	.68/.94	21/32	3/16
7/8-14	.68/.81/.87	53/64	.885	.75/.94/1.0	25/32	3/16
1-12	.87	15/16	1.020	1.0	27/32	5/16
1 1/8-12	1.12	1 1/16	1.145	1.31	31/32	5/16
1 1/4-12	1.12/1.25	1 3/16	1.270	1.31/1.44	1 3/32	5/16
1 3/8-12	1.25/1.37	1 5/16	1.395	1.44/1.56	1 7/32	5/16
1 1/2-12	1.37/1.62	1 7/16	1.520	1.56/1.84	1 11/32	5/16
1 5/8-12	1.81	1 9/16	1.640	2.06	1 15/32	5/16
1 7/8-12	2.00	1 13/16	1.890	2.28	1 23/32	5/16



Keylocking Inserts Thinwall Industrial Style

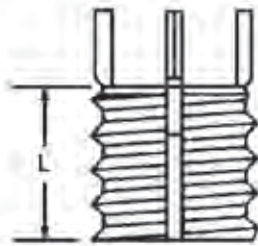

- Material: Carbon Steel Inserts - C1215 or equivalent
Stainless Steel Insert - 303 Keys - 302
- Finish: Carbon Steel Inserts - Parkerized
Stainless Steel Inserts - Passivated
- Tolerances: Inch \pm .010 Metric \pm .25mm
- Keys: Inserts with internal thread size of 5/16-18 or larger are furnished with four locking keys.
- RoHS compliant

Inch Inserts - Thinwall

Internal Thread Class 2B	Part Number		External Thread	Length L	Installation Tool Part Number
	Carbon Steel	Stainless Steel			
10-24	25921	26321	5/16-18	.31	24721
10-32	26121	26521	5/16-18	.31	24721
1/4-20	25922	26322	3/8-16	.37	24722
1/4-28	26122	26522	3/8-16	.37	24722
5/16-18	25923	26323	7/16-14	.43	24723
5/16-24	26123	26523	7/16-14	.43	24723
3/8-16	25924	26324	1/2-13	.50	24724
3/8-24	26124	26524	1/2-13	.50	24724
7/16-14	25925	26325	9/16-12	.56	24725
7/16-20	26125	26525	9/16-12	.56	24725
1/2-13	25926	26326	5/8-11	.62	24726
1/2-20	26126	26526	5/8-11	.62	24726

See chart on page 46 for installation information.

Metric Inserts - Thinwall

Part Number		Insert		Length L	Installation Tool Part No.	Tap Drill Size	C'sink Dia. +.25 -.00	Thread Tap		Removal Drill	
Carbon Steel	Stainless Steel	Internal Thread Class 6H	External Thread Class 6g					Size Class 6h	Min. Depth	Size	Depth
25952	26352	M 6x1.0	M 10x1.25	10.0	24752	8.8	10.25	M 10x1.25	11.5	7.50	4.75
25953	26353	M 8x1.25	M 12x1.25	12.0	24753	10.8	12.25	M 12x1.25	13.5	9.50	4.75
26153	26553	M 8x1.0	M 12x1.25	12.0	24753	10.8	12.25	M 12x1.25	13.5	9.50	4.75
25955	26355	M 10x1.5	M 14x1.5	14.0	24755	12.8	14.25	M 14x1.5	15.5	11.50	4.75
26155	26555	M 10x1.25	M 14x1.5	14.0	24755	12.8	14.25	M 14x1.5	15.5	11.50	4.75
25956	26356	M 12x1.75	M 16x1.5	16.0	24756	14.75	16.25	M 16x1.5	17.5	13.50	4.75
26156	26556	M 12x1.25	M 16x1.5	16.0	24756	14.75	16.25	M 16x1.5	17.5	13.50	4.75

Special materials, sizes and Mil-Spec available upon request



Keylocking Inserts Heavy Duty Industrial Style

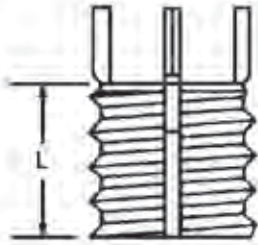

- Material: Carbon Steel Inserts - C1215 or equivalent
Stainless Steel Insert - 303
Keys - 302
- Finish: Carbon Steel Inserts - Parkerized
Stainless Steel Inserts - Passivated
- Tolerances: Inch $\pm .010$
Metric $\pm .25\text{mm}$
- Keys: Inserts with internal thread size of 5/16-18 or larger are furnished with four locking keys.
- RoHS compliant

Inch Inserts - Heavy Duty

Internal Thread Class 2B	Part Number		External Thread	Length L	Installation Tool Part Number
	Carbon Steel	Stainless Steel			
8-32	25900	26300	5/16-18	.31	24700
10-24	25901	26301	3/8-16	.31	24701
10-32	26101	26501	3/8-16	.31	24701
1/4-20	25902	26302	7/16-14	.37	24702
1/4-28	26102	26502	7/16-14	.37	24702
5/16-18	25903	26303	1/2-13	.43	24703
5/16-24	26103	26503	1/2-13	.43	24703
3/8-16	25904	26304	9/16-12	.50	24704
3/8-24	26104	26504	9/16-12	.50	24704
7/16-14	25905	26305	5/8-11	.62	24705
7/16-20	26105	26505	5/8-11	.62	24705
1/2-13	25906	26306	3/4-16	.62	24706
1/2-20	26106	26506	3/4-16	.62	24706
9/16-12	25907	26307	3/4-16	.81	24707
9/16-18	26107	26507	3/4-16	.81	24707
5/8-11	25908	26308	7/8-14	.87	24708
5/8-18	26108	26508	7/8-14	.87	24708
3/4-10	25909	26309	1 1/8-12	1.12	24709
3/4-16	26109	26509	1 1/8-12	1.12	24709
7/8-9	25910	26310	1 1/4-12	1.25	24710
7/8-14	26110	26510	1 1/4-12	1.25	24710
1-8	25911	26311	1 3/8-12	1.37	24711
1-12	26111	26511	1 3/8-12	1.37	24711
1-14	26112	—	1 3/8-12	1.37	24711
1 1/8-7	25913	—	1 1/2-12	1.62	24713
1 1/8-12	26113	—	1 1/2-12	1.62	24713
1 1/4-7	25914	—	1 5/8-12	1.81	24714
1 1/4-12	26114	—	1 5/8-12	1.81	24714
1 1/2-6	25916	—	1 7/8-12	2.00	24716
1 1/2-12	26116	—	1 7/8-12	2.00	24716

See chart on page 46 for installation information.

Metric Inserts - Heavy Duty

Part Number Carbon Steel	Part Number Stainless Steel	Insert			Installation					Removal	
		Internal Thread Class 6H	External Thread Class 6g	Length L	Installation Tool Part No.	Tap Drill Size	C'sink Diameter +.25 -.00	Thread Tap		Drill	
								Size Class 6h	Min. Depth	Size	Depth
25963	26363	M 4x0.7	M 8x1.25	8.0	24763	6.9	8.25	M 8x1.25	9.5	5.50	4.00
25964	26364	M 5x0.8	M 10x1.25	10.0	24764	8.8	10.25	M 10x1.25	12.5	7.50	4.75
25965	26365	M 6x1.0	M 12x1.25	12.0	24765	10.8	12.25	M 12x1.25	14.5	9.50	4.75
25966	26366	M 8x1.25	M 14x1.5	14.0	24766	12.8	14.25	M 14x1.5	16.5	11.50	4.75
26166	26566	M 8x1.0	M 14x1.5	14.0	24766	12.8	14.25	M 14x1.5	16.5	11.50	4.75
25967	26367	M 10x1.5	M 16x1.5	16.0	24767	14.75	16.25	M 16x1.5	18.5	13.50	4.75
26167	26567	M 10x1.25	M 16x1.5	16.0	24767	14.75	16.25	M 16x1.5	18.5	13.50	4.75
25969	26369	M 12x1.75	M 18x1.5	18.0	24769	16.75	18.25	M 18x1.5	20.5	15.50	4.75
26169	26569	M 12x1.25	M 18x1.5	18.0	24769	16.75	18.25	M 18x1.5	20.5	15.50	4.75
25970	26370	M 14x2.0	M 20x1.5	20.0	24770	18.75	20.25	M 20x1.5	22.5	17.50	4.75
26170	26570	M 14x1.5	M 20x1.5	20.0	24770	18.75	20.25	M 20x1.5	22.5	17.50	4.75
25971	26371	M 16x2.0	M 22x1.5	22.0	24771	20.5	22.25	M 22x1.5	24.5	17.75	6.35
26171	26571	M 16x1.5	M 22x1.5	22.0	24771	20.5	22.25	M 22x1.5	24.5	17.75	6.35
26172	26572	M 18x1.5	M 24x1.5	24.0	24772	22.5	24.25	M 24x1.5	26.5	19.75	6.35
25973	26373	M 20x2.5	M 30x2.0	30.0	24773	28.0	30.25	M 30x2.0	34.5	25.75	6.35
26173	26573	M 20x1.5	M 30x2.0	30.0	24773	28.0	30.25	M 30x2.0	34.5	25.75	6.35
26174	26574	M 22x1.5	M 32x2.0	32.0	24774	30.0	32.25	M 32x2.0	36.5	27.75	6.35
25975	26375	M 24x3.0	M 33x2.0	33.0	24775	31.0	33.25	M 33x2.0	37.5	28.75	6.35
26175	26575	M 24x2.0	M 33x2.0	33.0	24775	31.0	33.25	M 33x2.0	37.5	28.75	6.35

NOTE: Install insert .25mm to .76mm below surface and drive locking keys down. See C'sink Diameter column above.

Special materials, sizes and Mil-Spec available upon request



Keylocking Inserts Metric/Inch Inserts



Create Metric Holes... With Inch Taps!

This unique product allows you to create a metric thread utilizing inch drills and taps. The insert O.D. is inch sized, the I.D. is metric.

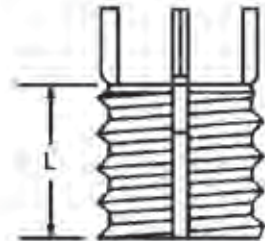

Metric Internal/Inch External - Heavy Duty Industrial Style

Part Number Carbon Steel	Insert			Installation					Removal	
	Internal Thread Class 6H	External Thread Class 2A	Length L	Installation Tool Part Number	Tap Drill Size	C'sink Diameter +.010 -.000	Thread Tap		Drill	
							Size Class 2b	Min. Depth	Size	Depth
26243	M 6x1.0	3/8 - 16	.31	24843	Q	.38	3/8 - 16	.37	9/32	1/8
26244	M 8x1.25	1/2 - 13	.43	24844	29/64	.51	1/2 - 13	.50	13/32	3/16
26245	M 10x1.5	5/8 - 11	.50	24845	37/64	.63	5/8 - 11	.56	17/32	3/16
26247	M 12x1.75	3/4 - 16	.62	24847	45/64	.76	3/4 - 16	.68	21/32	3/16
26248	M 14x2.0	7/8 - 14	.81	24848	53/64	.88	7/8 - 14	.94	25/32	5/16
26249	M 16x2.0	1" - 12	.87	24849	15/16	1.02	1" - 12	1.00	27/32	5/16

All dimensions are in inches except for internal thread, which is metric.

Bolster Plate Bushings



- Material: Stressproof
- Finish: Black Oxide
- Internal Thread: 2B-UNC
- External Thread: 2A-UNF

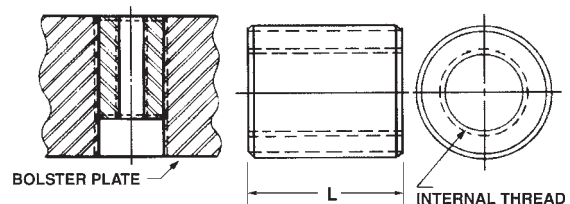

Repairs are made quickly, easily, and right on the machine. Re-tap bolster plate hole, insert the threaded bushing to match, use a locking type sealant to lock the bushing in place. The Bolster Plate Bushings can also be used as threaded bushings in cast iron machine bases where greater thread strength is necessary. Eliminates the problems of "pulled-out" cast iron threads, reduces the need for bulky threaded cast iron sections.

Part Number	Internal Thread	External Thread	L	Wt. (lbs) 10 Pcs.
11701	3/8-16	3/4-16	1 1/2	1.25
11702	1/2-13	1 -14	1 1/2	2.20
11703	5/8-11	1 -14	1 1/2	1.85
11704	3/4-10	1 1/4-12	1 1/2	3.00
11705	1 -8	1 1/2-12	2	5.15

Special materials, sizes and Mil-Spec available upon request



Keylocking Inserts Extra Heavy Duty Industrial Style

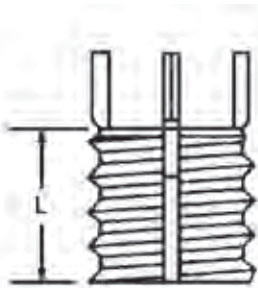

The increased wall thickness and greater external thread area of these extra heavy duty threaded inserts offer greater pull-out strength, stability, and longer life. These inserts should be used in materials with lower ultimate shear strength to obtain maximum pull-out strength and holding power.

- Greater Thread Area
- Increased Shear Engagement
- Offers Holding Power Comparable to Standard Heavy Duty Inserts in High Shear Strength Material
- Material: Carbon Steel Inserts - C1215 or equivalent
Stainless Steel Insert - 303
Keys - 302
- Finish: Carbon Steel Inserts - Parkerized
Stainless Steel Inserts - Passivated
- Tolerances: ±.010
- Keys: Inserts with internal thread size of 5/16-18 or larger are furnished with four locking keys.
- RoHS compliant

Internal Thread Class 2B	Part Number		External Thread Class 2A	Length L	Installation Tool Part Number
	Carbon Steel	Stainless Steel			
6-32	25931	26331	5/16-18	.31	24731
8-32	25932	26332	3/8-16	.31	24732
10-24	25933	26333	7/16-14	.31	24733
10-32	26133	26533	7/16-14	.31	24733
1/4-20	25934	26334	1/2-13	.37	24734
1/4-28	26134	26534	1/2-13	.37	24734
5/16-18	25935	26335	9/16-12	.43	24735
5/16-24	26135	26535	9/16-12	.43	24735
3/8-16	25936	26336	5/8-11	.50	24736
3/8-24	26136	26536	5/8-11	.50	24736
7/16-14	25937	26337	3/4-16	.62	24737
7/16-20	26137	26537	3/4-16	.62	24737
1/2-13	25938	26338	7/8-14	.68	24738
1/2-20	26138	26538	7/8-14	.68	24738
9/16-12	25939	26339	7/8-14	.81	24739
9/16-18	26139	26539	7/8-14	.81	24739
5/8-11	25940	26340	1-12	.87	24740
5/8-18	26140	26540	1-12	.87	24740
3/4-10	25941	26341	1 1/4-12	1.12	24741
3/4-16	26141	26541	1 1/4-12	1.12	24741
7/8-9	25942	26342	1 3/8-12	1.25	24742
7/8-14	26142	26542	1 3/8-12	1.25	24742
1-8	25943	26343	1 1/2-12	1.37	24743
1-12	26143	26543	1 1/2-12	1.37	24743

See chart on page 46 for installation information.

Special materials, sizes and Mil-Spec available upon request



Keylocking Inserts Solid Industrial Style

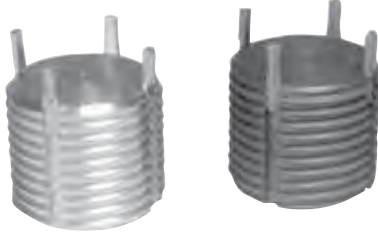

- Material: Carbon Steel Inserts - C1215 or equivalent
Stainless Steel Insert - 303
Keys - 302
- Finish: Carbon Steel Inserts - Parkerized
Stainless Steel Inserts - Passivated
- Tolerances: Inch \pm .010
Metric \pm .25mm
- Keys: Inserts with internal thread size of M7 or larger are furnished with four locking keys.
- RoHS compliant

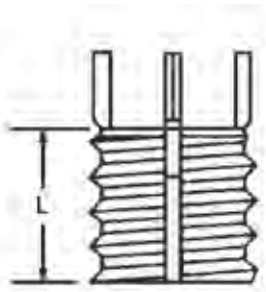

- Salvage expensive castings
- Relocate holes that have been drilled or tapped in the wrong location
- Fill holes that are too large
- No need to alter original bolt size

External Thread Class 2A	Part Number		Length L	Installation Tool Part Number
	Carbon Steel	Stainless Steel		
5/16-18	26001	26401	.31	24801
3/8-16	26002	26402	.31	24802
7/16-14	26003	26403	.37	24803
1/2-13	26004	26404	.43	24804
9/16-12	26005	26405	.50	24805
5/8-11	26006	26406	.62	24806
3/4-16	26007	26407	.68	24807
7/8-14	26008	26408	.87	24808
1-12	26009	26409	.87	24809
1 1/8-12	26010	26410	1.12	24810
1 1/4-12	26011	26411	1.25	24811
1 3/8-12	26012	26412	1.37	24812

See chart on page 46 for installation information.

Metric Inserts - Solid

Part Number Carbon Steel	Insert		Installation					Removal	
	External Thread Class 6g	Length L	Installation Tool Part No.	Tap Drill Size	C'sink Dia. +.25 -.00	Thread Tap		Drill	
						Size Class 6h	Min. Depth	Size	Depth
26021	M 8x1.25	8.0	24821	6.9	8.25	M 8x1.25	9.5	5.50	4.00
26022	M 10x1.25	10.0	24822	8.8	10.25	M 10x1.25	12.5	7.50	4.75
26023	M 12x1.25	12.0	24823	10.8	12.25	M 12x1.25	14.5	9.50	4.75
26024	M 14x1.5	14.0	24824	12.8	14.25	M 14x1.5	16.5	11.50	4.75
26025	M 16x1.5	16.0	24825	14.75	16.25	M 16x1.5	18.5	13.50	4.75
26026	M 18x1.5	18.0	24826	16.75	18.25	M 18x1.5	20.5	15.50	4.75
26027	M 20x1.5	20.0	24827	18.75	20.25	M 20x1.5	22.5	17.50	4.75
26028	M 22x1.5	22.0	24828	20.5	22.25	M 22x1.5	24.5	17.75	6.35
26029	M 24x1.5	24.0	24829	22.5	24.25	M 24x1.5	26.5	19.75	6.35
26030	M 30x2.0	30.0	24830	28.0	30.25	M 30x2.0	34.5	25.75	6.35
26031	M 32x2.0	32.0	24831	30.0	32.25	M 32x2.0	36.5	27.75	6.35
26032	M 33x2.0	33.0	24832	31.0	33.25	M 33x2.0	37.5	28.75	6.35

Special materials, sizes and Mil-Spec available upon request



Internal Locking Thread Repair Inserts

Material: Inserts - 303 stainless steel or equivalent
 Keys - 302 stainless steel or equivalent
 Finish: Passivated
 Tolerances: ± .010 inch unless specified otherwise.
 Dimensions: All dimensions below are in inches.
 Keys: Inserts with an internal thread size of 5/16 and larger are furnished with 4 locking keys. Smaller sizes have 2 locking keys.
 RoHS compliant

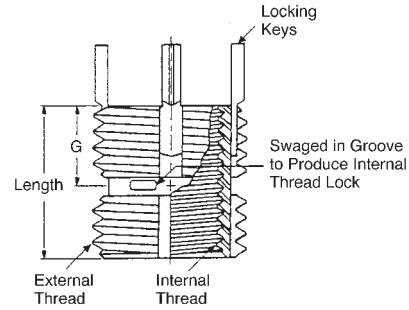

Thinwall - Locking

Part Number	Insert				Installation					Removal	
	Internal Thread Class 2B	External Thread (Mod.) Class 2A	Length	G (Ref.)	Installation Tool Part No.	Tap Drill Size	C'sink Dia +.010 -.000	Thread Tap		Drill	
								Size Class 2B	Min. Depth	Size	Depth
24521	10 - 24	5/16 - 18	.31	.15	24721	"I"	.32	5/16 - 18	.37	7/32	1/8
24621	10 - 32										
24522	1/4 - 20	3/8 - 16	.37	.18	24722	"Q"	.38	3/8 - 16	.43	9/32	3/16
24622	1/4 - 28										
24523	5/16 - 18	7/16 - 14	.43	.21	24723	"X"	.44	7/16 - 14	.50	11/32	3/16
24623	5/16 - 24										
24524	3/8 - 16	1/2 - 13	.50	.25	24724	29/64	.51	1/2 - 13	.56	13/32	3/16
24624	3/8 - 24										
24525	7/16 - 14	9/16 - 12	.56	.28	24725	33/64	.57	9/16 - 12	.62	15/32	3/16
24625	7/16 - 20										
24526	1/2 - 13	5/8 - 11	.62	.31	24726	37/64	.63	5/8 - 11	.68	17/32	3/16
24626	1/2 - 20										

Heavy Duty - Locking

Part Number	Insert				Installation					Removal	
	Internal Thread Class 2B	External Thread (Mod.) Class 2A	Length	G (Ref.)	Installation Tool Part No.	Tap Drill Size	C'sink Dia +.010 -.000	Thread Tap		Drill	
								Size Class 2B	Min. Depth	Size	Depth
24500	8 - 32	5/16 - 18	.31	.15	24700	"I"	.32	5/16 - 18	.37	7/32	1/8
24501	10 - 24	3/8 - 16	.31	.15	24701	"Q"	.38	3/8 - 16	.37	9/32	1/8
24601	10 - 32										
24502	1/4 - 20	7/16 - 14	.37	.18	24702	"X"	.44	7/16 - 14	.43	11/32	3/16
24602	1/4 - 28										
24503	5/16 - 18	1/2 - 13	.43	.21	24703	29/64	.51	1/2 - 13	.50	13/32	3/16
24603	5/16 - 24										
24504	3/8 - 16	9/16 - 12	.50	.25	24704	33/64	.57	9/16 - 12	.56	15/32	3/16
24604	3/8 - 24										
24505	7/16 - 14	5/8 - 11	.62	.31	24705	37/64	.63	5/8 - 11	.68	17/32	3/16
24605	7/16 - 20										
24506	1/2 - 13	3/4 - 16	.62	.31	24706	45/64	.76	3/4 - 16	.68	21/32	3/16
24606	1/2 - 20										
24507	9/16 - 12	3/4 - 16	.81	.40	24707	45/64	.76	3/4 - 16	.94	21/32	3/16
24607	9/16 - 18										
24508	5/8 - 11	7/8 - 14	.87	.43	24708	53/64	.88	7/8 - 14	1.00	25/32	5/16
24608	5/8 - 18										
24509	3/4 - 10	1-1/8 - 12	1.12	.56	24709	1-1/16	1.14	1-1/8 - 12	1.31	31/32	5/16
24609	3/4 - 16										
24510	7/8 - 9	1-1/4 - 12	1.25	.62	24710	1-3/16	1.27	1-1/4 - 12	1.44	1-3/32	5/16
24610	7/8 - 14										
24511	1" - 8	1-3/8 - 12	1.37	.68	24711	1-5/16	1.39	1-3/8 - 12	1.56	1-7/32	5/16
24611	1" - 12										

Special materials, sizes and Mil-Spec available upon request



Metric Internal Locking Thread Repair Inserts

Material: Inserts - 303 stainless steel or equivalent
 Keys - 302 stainless steel or equivalent
 Finish: Passivated
 Tolerances: ±.25 mm unless specified otherwise.
 Dimensions: All dimensions below are in millimeters
 Keys: Inserts with an internal thread size of M7 and larger are furnished with 4 locking keys. Smaller sizes have 2 locking keys.
 RoHS compliant

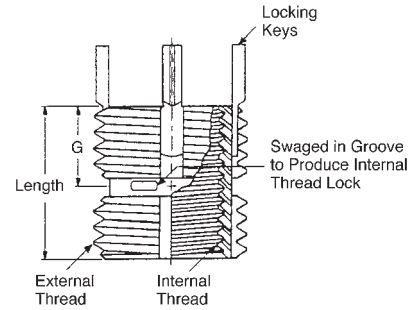

Thinwall - Metric - Locking

Part Number	Insert				Installation					Removal	
	Internal Thread Class 6H	External Thread Class 6g	Length	G (Ref.)	Installation Tool Part No.	Tap Drill Size	C'sink Dia. +.25 -.00	Thread Tap		Drill	
								Size Class 6h	Min. Depth	Size	Depth
24551	M 5x0.8	M 8x1.25	8.0	4.0	24751	6.9	8.25	M 8x1.25	9.5	5.50	4.00
24552	M 6x1.0	M 10x1.25	10.0	5.0	24752	8.8	10.25	M 10x1.25	11.5	7.50	4.75
24553	M 8x1.25	M 12x1.25	12.0	6.0	24753	10.8	12.25	M 12x1.25	13.5	9.50	4.75
24653	M 8x1.0										
24555	M 10x1.5	M 14x1.5	14.0	7.0	24755	12.8	14.25	M 14x1.5	15.5	11.50	4.75
24655	M 10x1.25										
24556	M 12x1.75	M 16x1.5	16.0	8.0	24756	14.75	16.25	M 16x1.5	17.5	13.50	4.75
24656	M 12x1.25										

Heavy Duty - Metric - Locking

Part Number	Insert				Installation					Removal	
	Internal Thread Class 6H	External Thread Class 6g	Length	G (Ref.)	Installation Tool Part No.	Tap Drill Size	C'sink Dia. +.25 -.00	Thread Tap		Drill	
								Size Class 6h	Min. Depth	Size	Depth
24563	M 4X0.7	M 8x1.25	8.0	4.0	24763	6.9	8.25	M 8x1.25	9.5	5.50	4.00
24564	M 5x0.8	M 10x1.25	10.0	5.0	24764	8.8	10.25	M 10x1.25	12.5	7.50	4.75
24565	M 6x1.0	M 12x1.25	12.0	6.0	24765	10.8	12.25	M 12x1.25	14.5	9.50	4.75
24566	M 8x1.25	M 14x1.5	14.0	7.0	24766	12.8	14.25	M 14x1.5	16.5	11.50	4.75
24666	M 8x1.0										
24567	M 10x1.5	M 16x1.5	16.0	8.0	24767	14.75	16.25	M 16x1.5	18.5	13.50	4.75
24667	M 10x1.25										
24569	M 12x1.75	M 18x1.5	18.0	9.0	24769	16.75	18.25	M 18x1.5	20.5	15.50	4.75
24669	M 12x1.25										
24570	M 14x2.0	M 20x1.5	20.0	10.0	24770	18.75	20.25	M 20x1.5	22.5	17.50	4.75
24670	M 14x1.5										
24571	M 16x2.0	M 22x1.5	22.0	11.0	24771	20.5	22.25	M 22x1.5	24.5	17.75	6.35
24671	M 16x1.5										
24672	M 18x1.5	M 24x1.5	24.0	12.0	24772	22.5	24.25	M 24x1.5	26.5	19.75	6.35
24573	M 20x2.5	M 30x2.0	30.0	15.0	24773	28.0	30.25	M 30x2.0	34.5	25.75	6.35
24673	M 20x1.5										
24674	M 22x1.5	M 32x2.0	32.0	16.0	24774	30.0	32.25	M 32x2.0	36.5	27.75	6.35
24575	M 24x3.0	M 33x2.0	33.0	16.5	24775	31.0	33.25	M 33x2.0	37.5	28.75	6.35
24675	M 24x2.0										

Special materials, sizes and Mil-Spec available upon request



Miniature - Metric 303 CRES Keylocking Threaded Inserts

Material: Inserts - 303 CRES
Keys - 302 CRES

Finish: Passivated

Tolerances: $\pm .25$ mm unless specified otherwise

Internal Threads: Per Fed Std H28/21, MJ Form

Dimensions: All dimensions below are in millimeters

Keys: Miniature Inserts are furnished with 2 locking keys

Material Identification Mark: None

Lubrication: Dry Film Lube on Self-Locking Inserts only

RoHS compliant

Non-Locking

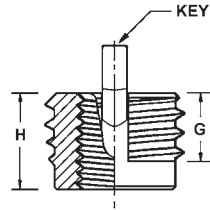

Self-Locking

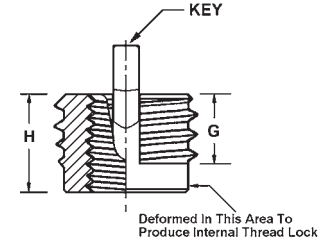

Part Number*			Insert			Installation					Removal	
Non-Locking	Self-Locking	Internal Thread Class 4H6H	External Thread Class 4h	Thread Length G	Length H	Install Tool Part No*	Tap Drill Size $+ .080 / - .025$	C'Sink Dia. $+ .25 / - .00$	Thread Tap		Drill	
									Size Class 6H	Min. Depth	Size	Depth
26382	27382	M 2x0.4	M 4x0.7	2.20	3.00	22682	3.4	4.1	M 4x0.7	4.0	2.8	2.00
26383	27383	M 2.5x0.45	M 4.5x0.75	2.70	3.81	22683	3.9	4.6	M 4.5x0.75	5.0	3.0	2.00
26384	27384	M 3x0.5	M 5x0.8	3.10	4.25	22684	4.4	5.1	M 5x0.8	5.5	3.5	2.25
26386	27386	M 4x0.7	M 6x0.75	4.11	5.25	22686	5.5	6.1	M 6x0.75	6.5	4.6	2.50

Miniature - Inch 303 CRES Keylocking Threaded Inserts

Material: Inserts - 303 CRES
Keys - 302 CRES

Finish: Passivated

Tolerances: $\pm .010$ inch unless specified otherwise

Internal Threads: Per SAE AS8879

Dimensions: All dimensions below are in inches

Keys: Miniature Inserts are furnished with 2 locking keys

Material Identification Mark: None

Lubrication: Dry Film Lube on Self-Locking Inserts only

RoHS compliant

Non-Locking

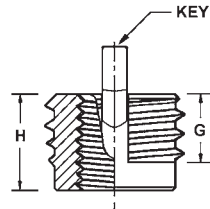

Self-Locking

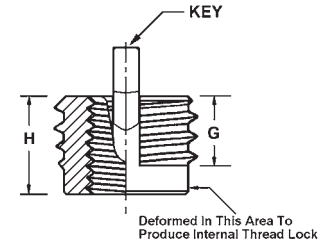

Part Number*			Insert			Installation					Removal	
Non-Locking	Self-Locking	Internal Thread Class 3B	External Thread Class 2A	G Thread Length	H Length	Install Tool Part No*	Tap Drill Size $+ .003 / - .001$	C'Sink Dia. $+ .010 / - .000$	Thread Tap		Drill	
									Size Class 2B	Min. Depth	Size	Depth
26283	27283	2 - 56	8 - 32	.090	.120	22552	.134	.166	8 - 32	.140	#33	1/16
26284	27284	4 - 40	10 - 32	.125	.170	22554	.161	.194	10 - 32	.160	#29	3/32
26285	27285	6 - 32	12 - 28	.125	.170	22556	.187	.220	12 - 28	.160	#21	3/32
26286	27286	8 - 32	1/4 - 28 [†]	.175	.220	22558	.228	.255	1/4 - 28	.210	#8	1/8

[†] Modified Minor Diameter

High Strength Materials Available: These miniature inserts are also manufactured in high strength stainless steel (A-286 with heat treatment) and in alloy steel (4140 with heat treatment).

Special materials, sizes and Mil-Spec available upon request



MS/NAS Style Insert

Jergens now offers Mil-Spec Keylocking Threaded Inserts



Thread Inserts

- Inch and metric sizes available
- Standard Material: 303 CRES
C1215
- Special Material: A286 CRES
4140 Alloy Steel

Insert Style
Miniature & Lightweight MS 51830/NAS 1394
Heavy Duty MS 51831/NAS 1395
Extra Heavy Duty MS 51832

**Please contact Jergens
for cross reference and
ordering information.
1-866-KWIK-LOK (594-5565)**



Master Thread Repair Kits Small Assortments



The Jergens Master Thread Repair Kits include several different kinds of inserts, installation tools and installation and removal instructions.

The Kits are available with inch or metric, carbon steel inserts or with stainless steel inserts.

Coarse Series, Heavy Duty Kits

Internal Thread Class 2B	External Thread (Mod) Class 2A	Length	Quantity of Inserts Per Kit
10 - 24	3/8 - 16	.31	5
1/4 - 20	7/16 - 14	.37	10
5/16 - 18	1/2 - 13	.43	10
3/8 - 16	9/16 - 12	.50	10
1/2 - 13	3/4 - 16	.62	10
5/8 - 11	7/8 - 14	.87	10
3/4 - 10	1-1/8 - 12	1.12	5

Total Inserts Per Kit 60 pcs.

Carbon Steel Kit
25949

Stainless Steel Kit
26349

Fine Series, Heavy Duty Kits

Internal Thread Class 2B	External Thread Class 2A	Length	Quantity of Inserts Per Kit
10 - 32	3/8 - 16	.31	5
1/4 - 28	7/16 - 14	.37	10
5/16 - 24	1/2 - 13	.43	10
3/8 - 24	9/16 - 12	.50	10
1/2 - 20	3/4 - 16	.62	10
5/8 - 18	7/8 - 14	.87	10
3/4 - 16	1-1/8 - 12	1.12	5

Total Inserts Per Kit 60 pcs.

Carbon Steel Kit
26149

Stainless Steel Kit
26549

Metric, Thinwall Kits

Internal Thread Class 2B	External Thread Class 2A	Length (mm)	Quantity of Inserts Per Kit
M 5x0.8	M 8x1.25	8.0	8
M 6x1.0	M 10x1.25	10.0	8
M 8x1.25	M 12x1.25	12.0	6
M 8x1.0	M 12x1.25	12.0	6
M 10x1.5	M 14x1.5	14.0	4
M 10x1.25	M 14x1.5	14.0	4
M 12x1.75	M 16x1.5	16.0	3
M 12x1.25	M 16x1.5	16.0	3

Total Inserts Per Kit 42 pcs.

Metric Carbon Steel Kit
25999

Stainless Steel Kit
25998



Master Thread Repair Kits Large Assortments

Coarse Series, Heavy Duty Kits

Internal Thread Class 2B	External Thread (Mod) Class 2A	Length	Quantity of Inserts Per Kit
1/4 - 20	7/16 - 14	.37	20
5/16 - 18	1/2 - 13	.43	15
3/8 - 16	9/16 - 12	.50	10
7/16 - 14	5/8 - 11	.62	10
1/2 - 13	3/4 - 16	.62	6
9/16 - 12	3/4 - 16	.81	5
5/8 - 11	7/8 - 14	.87	3
3/4 - 10	1-1/8 - 12	1.12	3
7/8 - 9	1-1/4 - 12	1.25	3
1" - 8	1-3/8 - 12	1.37	2

Total Inserts Per Kit 77 pcs.

Carbon Steel Kit
25945

Stainless Steel Kit
26345

Fine Series, Heavy Duty Kits

Internal Thread Class 2B	External Thread (Mod) Class 2A	Length	Quantity of Inserts Per Kit
1/4 - 28	7/16 - 14	.37	10
5/16 - 24	1/2 - 13	.43	10
3/8 - 24	9/16 - 12	.50	10
7/16 - 20	5/8 - 11	.62	10
1/2 - 20	3/4 - 16	.62	6
9/16 - 18	3/4 - 16	.81	5
5/8 - 18	7/8 - 14	.87	3
3/4 - 16	1-1/8 - 12	1.12	3
7/8 - 14	1-1/4 - 12	1.25	3
1" - 12	1-3/8 - 12	1.37	2

Total Inserts Per Kit 77 pcs.

Carbon Steel Kit
26145

Stainless Steel Kit
26545

Metric, Thinwall Kits

Internal Thread Class 6H	External Thread Class 6g	Length (mm)	Quantity of Inserts Per Kit
M 6x1.0	M 10x1.25	10.0	20
M 8x1.25	M 12x1.25	12.0	15
M 8x1.0	M 12x1.25	12.0	15
M 10x1.5	M 14x1.5	14.0	10
M 10x1.25	M 14x1.5	14.0	10
M 12x1.75	M 16x1.5	16.0	6
M 12x1.25	M 16x1.5	16.0	6

Total Inserts Per Kit 82 pcs.

Metric Carbon Steel Kit
25997

Stainless Steel Kit
25996

Coarse Series, Thinwall Kits

Internal Thread Class 2B	External Thread (Mod) Class 2A	Length	Quantity of Inserts Per Kit
10 - 24	5/16 - 18	.31	20
1/4 - 20	3/8 - 16	.37	20
5/16 - 18	7/16 - 14	.43	15
3/8 - 16	1/2 - 13	.50	10
7/16 - 14	9/16 - 12	.56	10
1/2 - 13	5/8 - 11	.62	6

Total Inserts Per Kit 81 pcs.

Carbon Steel Kit
25948

Stainless Steel Kit
26348

Fine Series, Thinwall Kits

Internal Thread Class 2B	External Thread (Mod) Class 2A	Length	Quantity of Inserts Per Kit
10 - 32	5/16 - 18	.31	20
1/4 - 28	3/8 - 16	.37	20
5/16 - 24	7/16 - 14	.43	15
3/8 - 24	1/2 - 13	.50	10
7/16 - 20	9/16 - 12	.56	10
1/2 - 20	5/8 - 11	.62	6

Total Inserts Per Kit 81 pcs.

Carbon Steel Kit
25947

Stainless Steel Kit
26548



Inch Thread Repair Insert Kits



The Jergens Keylocking Inserts provide strong and durable threads in most types of material. They are easily installed using standard drills and taps.

The Jergens Thread Repair Insert Kits include inserts, an installation tool, and installation and removal instructions.

The Kits are available with either inch, metric, or metric internal/inch external carbon steel inserts.

Each Kit is comprised of one size of insert in various quantities. For Thread Repair Kits that include several different sizes, see pages 56 – 57.

Inch Thread Kits - Heavy Duty

Carbon Steel Part Number	Stainless Steel Part Number	Internal Thread	External Thread	Inserts Per Kit	Insert Part Number	Stainless Steel Insert Part Number	Tool Part Number
75900	76300	8-32	5/16-18	9	25900	26300	24700
75901	76301	10-24	3/8-16	9	25901	26301	24701
76101	76501	10-32	3/8-16	9	26101	26501	24701
75902	76302	1/4-20	7/16-14	8	25902	26302	24702
76102	76502	1/4-28	7/16-14	8	26102	26502	24702
75903	76303	5/16-18	1/2-13	7	25903	26303	24703
76103	76503	5/16-24	1/2-13	7	26103	26503	24703
75904	76304	3/8-16	9/16-12	6	25904	26304	24704
76104	76504	3/8-24	9/16-12	6	26104	26504	24704
75905	76305	7/16-14	5/8-11	6	25905	26305	24705
76105	76505	7/16-20	5/8-11	6	26105	26505	24705
75906	76306	1/2-13	3/4-16	4	25906	26306	24706
76106	76506	1/2-20	3/4-16	4	26106	26506	24706
75907	76307	9/16-12	3/4-16	3	25907	26307	24707
76107	76507	9/16-18	3/4-16	3	26107	26507	24707
75908	76308	5/8-11	7/8-14	3	25908	26308	24708
76108	76508	5/8-18	7/8-14	3	26108	26508	24708
75909	76309	3/4-10	1 1/8-12	3	25909	26309	24709
76109	76509	3/4-16	1 1/8-12	3	26109	26509	24709
75910	76310	7/8-9	1 1/4-12	3	25910	26310	24710
76110	76510	7/8-14	1 1/4-12	3	26110	26510	24710
75911	76311	1 - 8	1 3/8-12	2	25911	26311	24711
76111	76511	1 - 12	1 3/8-12	2	26111	26511	24711
75913	—	1 1/8-7	1 1/2-12	2	25913	—	24713
76113	—	1 1/8-12	1 1/2-12	2	26113	—	24713
75914	—	1 1/4-7	1 5/8-12	2	25914	—	24714
76114	—	1 1/4-12	1 5/8-12	2	26114	—	24714
75916	—	1 1/2-6	1 7/8-12	2	25916	—	24716
76116	—	1 1/2-12	1 7/8-12	2	26116	—	24716

Inch Thread Kits - Thin Wall

Carbon Steel Part Number	Stainless Steel Part Number	Internal Thread	External Thread	Inserts Per Kit	Carbon Steel Insert Part Number	Stainless Steel Insert Part Number	Installation Tool Part Number
75921	76421	10-24	5/16-18	9	25921	26321	24721
76121	76521	10-32	5/16-18	9	26121	26521	24721
75922	76422	1/4-20	3/8-16	8	25922	26322	24722
76122	76522	1/4-28	3/8-16	8	26122	26522	24722
75923	76423	5/16-18	7/16-14	7	25923	26323	24723
76123	76523	5/16-24	7/16-14	7	26123	26523	24723
75924	76424	3/8-16	1/2-13	6	25924	26325	24724
76124	76524	3/8-24	1/2-13	6	26124	26524	24724
75925	76425	7/16-14	9/16-12	6	25925	26325	24725
76125	76525	7/16-20	9/16-12	6	26125	26525	24725
75926	76426	1/2-13	5/8-11	4	25926	26326	24726
76126	76526	1/2-20	5/8-11	4	26126	26526	24726



Metric Thread Repair Insert Kits



The Jergens Keylocking Inserts provide strong and durable threads in most types of material. They are easily installed using standard drills and taps.

The Jergens Thread Repair Insert Kits include inserts, an installation tool, and installation and removal instructions.

The Kits are available with either inch, metric, or metric internal/inch external carbon steel inserts.

Each Kit is comprised of one size of insert in various quantities. For Thread Repair Kits that include several different sizes, see pages 56 – 57.

Metric Thread Kits - Heavy Duty

Carbon Steel Part Number	Stainless Steel Part Number	Internal Thread	External Thread	Inserts Per Kit	Insert Part Number	Stainless Steel Insert Part Number	Tool Part Number
75963	76463	M4x0.7	M8x1.25	9	25963	26363	24763
75964	76464	M5x0.8	M10x1.25	8	25964	26364	24764
75965	76465	M6x1.0	M12x1.25	8	25965	26365	24765
75966	76466	M8x1.25	M14x1.5	6	25966	26366	24766
76166	76566	M8x1.0	M14x1.5	6	26166	26566	24766
75967	76467	M10x1.5	M16x1.5	4	25967	26367	24767
76167	76567	M10x1.25	M16x1.5	4	26167	26567	24767
75969	76469	M12x1.75	M18x1.5	3	25969	26369	24769
76169	76569	M12x1.25	M18x1.5	3	26169	26569	24769
75970	76470	M14x2.0	M20x1.5	4	25970	26370	24770
76170	76570	M14x1.5	M20x1.5	4	26170	26570	24770
75971	76471	M16x2.0	M22x1.5	3	25971	26371	24771
76171	76571	M16x1.5	M22x1.5	3	26171	26571	24771
76172	76572	M18x1.5	M24x1.5	2	26172	26572	24772
75973	76473	M20x2.5	M30x2.0	3	25973	26373	24773
76173	76573	M20x1.5	M30x2.0	3	26173	26573	24773
76174	76574	M22x1.5	M32x2.0	3	26174	26574	24774
75975	76475	M24x3.0	M33x2.0	3	25975	26375	24775
76175	76575	M24x2.0	M33x2.0	2	26175	26575	24775

Metric Thread - Thin Wall

Carbon Steel Part Number	Stainless Steel Part Number	Internal Thread	External Thread	Inserts Per Kit	Insert Part Number	Stainless Steel Insert Part Number	Tool Part Number
75951	76451	M5x0.8	M8x1.25	8	25951	26351	24751
75952	76452	M6x1.0	M10x1.25	8	25952	26352	24752
75953	76453	M8x1.25	M12x1.25	6	25953	26353	24753
76153	76553	M8x1.0	M12x1.25	6	26153	26553	24753
75955	76455	M10x1.5	M14x1.5	4	25955	26355	24755
76155	76555	M10x1.25	M14x1.5	4	26155	26555	24755
75956	76456	M12x1.75	M16x1.5	3	25956	26356	24756
76156	76556	M12x1.25	M16x1.5	3	26156	26556	24756

Carbon Steel Kits - Metric Internal/Inch External Threads - Heavy Duty

Part Number	Internal Thread	External Thread	Inserts Per Kit	Insert Part Number	Tool Part Number
76243	M 6x1.0	3/8 - 16	8	26243	24843
76244	M 8x1.25	1/2 - 13	8	26244	24844
76245	M 10x1.5	5/8 - 11	6	26245	24845
76247	M 12x1.75	3/4 - 16	4	26247	24847
76248	M 14x2.0	7/8 - 14	3	26248	24848
76249	M 16x2.0	1" - 12	3	26249	24849

THE **Jergens**® DIFFERENCE

Keylocking Inserts

OURS

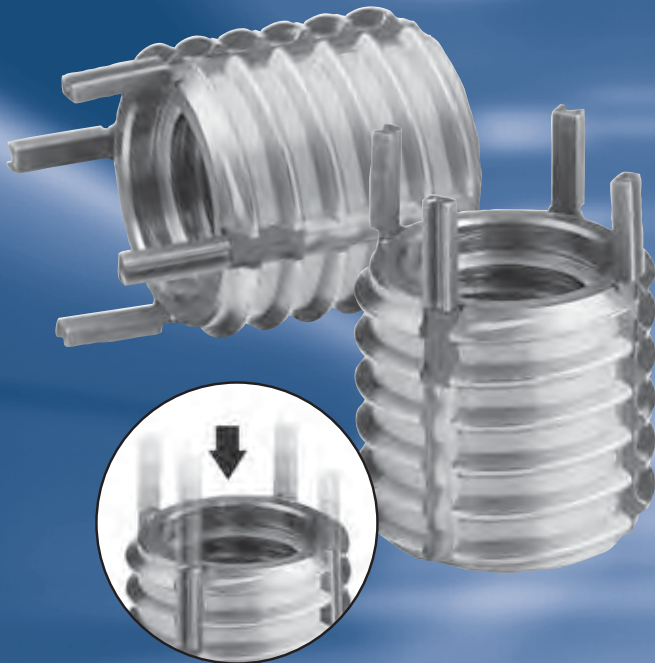

Jergens keylocking inserts are easy to install with standard drills and taps.

THEIRS



Competitive thread repair devices require special drills, taps, and installation tools.

JERGENS KEYLOCKING INSERTS

VS. THREAD REPAIR FROM OTHER MANUFACTURERS

Easy installation requires no special tools: uses standard drills and standard taps.

Installation requires special drills, taps, and installation tools.

“Keys” mechanically lock the insert into the base material.

Springs or locking patches do not mechanically lock the insert.

Rated among the highest in pullout strength of any thread repair device on the market.

Less pullout strength versus Jergens inserts.

Wide variety of styles, including thinwall, heavy duty, extra heavy duty, and solid inserts in both stainless steel and carbon steel materials.

Limited offerings may force you to settle on a device that doesn't meet all of your needs.

MISCELLANEOUS FASTENERS

Miscellaneous Fasteners

Clevis Pins	68
Leveling Mounts	69
Pull Dowel Pins.....	62-65
Rod Ends	66
Washers, Heavy Duty Flat.....	70
Yokes.....	67

Jergens[®]

MANUFACTURING EFFICIENCY



Alloy Steel Pull Dowel Pins

Jergens Offers 3 Styles of Precision Ground Pull Dowels



**Spiral Groove
(Grooves Help to Relieve Trapped Air)**

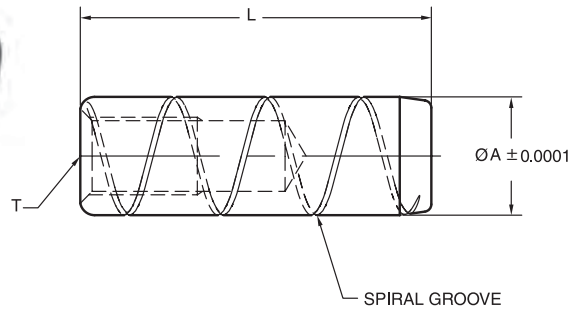

Features, Applications & Benefits

- Internally threaded hole allows removal of pull dowels with a standard screw.
- Standard Round Pull Dowels are typically used in applications featuring a through hole.
- Spiral Groove Pull Dowels feature a groove cut to allow trapped air to be released.
- Flat Vent Pull Dowels feature a ground flat on one side to release trapped air.



**Flat Vent
(Ground Flat Helps to Relieve Trapped Air)**

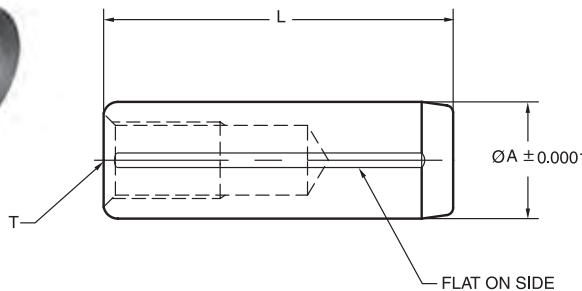

- Spiral Groove and Flat Vent Pull Dowels are typically used in blind hole applications
- Special materials and sizes available upon request.
- All of Jergens Precision Ground Pull Dowels are constructed of heat treated alloy steel.



**Standard Round
(Non-Vented)**

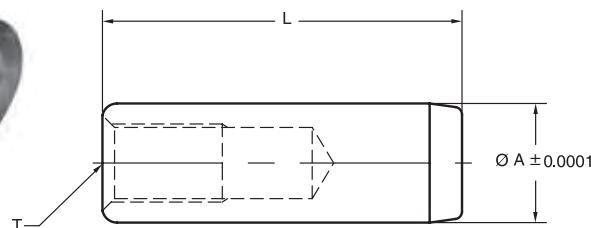

Special materials and sizes available upon request



Precision Ground Pull Dowels

Spiral Groove	Flat Vent	Standard Round	Nominal	Actual	Length	Internal Thread
31800	31400	31600	1/4	.2502	1/2	8 - 32
31801	31401	31601	1/4	.2502	3/4	8 - 32
31802	31402	31602	1/4	.2502	1	8 - 32
31803	31403	31603	1/4	.2502	1-1/4	8 - 32
31804	31404	31604	1/4	.2502	1-1/2	8 - 32
31805	31405	31605	1/4	.2502	1-3/4	8 - 32
31806	31406	31606	1/4	.2502	2	8 - 32
31807	31407	31654	1/4	.2502	2-1/4	8 - 32
31808	31408	31607	1/4	.2502	2-1/2	8 - 32
31809	31409	31608	5/16	.3127	3/4	10 - 32
31810	31410	31609	5/16	.3127	1	10 - 32
31811	31411	31610	5/16	.3127	1-1/4	10 - 32
31812	31412	31611	5/16	.3127	1-1/2	10 - 32
31813	31413	31612	5/16	.3127	2	10 - 32
31814	31414	31613	5/16	.3127	2-1/4	10 - 32
31815	31415	31614	5/16	.3127	2-1/2	10 - 32
31816	31416	31615	3/8	.3752	3/4	10 - 32
31817	31417	31616	3/8	.3752	1	10 - 32
31818	31418	31617	3/8	.3752	1-1/4	10 - 32
31819	31419	31618	3/8	.3752	1-1/2	10 - 32
31820	31420	31619	3/8	.3752	1-3/4	10 - 32
31821	31421	31620	3/8	.3752	2	10 - 32
31822	31422	31621	3/8	.3752	2-1/4	10 - 32
31823	31423	31622	3/8	.3752	2-1/2	10 - 32
31824	31424	31623	3/8	.3752	3	10 - 32
31825	31425	31624	7/16	.4377	1	1/4 - 20
31826	31426	31625	7/16	.4377	1-1/2	1/4 - 20
31827	31427	31626	7/16	.4377	2	1/4 - 20
31828	31428	31627	1/2	.5002	3/4	1/4 - 20
31829	31429	31628	1/2	.5002	1	1/4 - 20
31830	31430	31629	1/2	.5002	1-1/4	1/4 - 20
31831	31431	31630	1/2	.5002	1-1/2	1/4 - 20
31832	31432	31631	1/2	.5002	1-3/4	1/4 - 20
31833	31433	31632	1/2	.5002	2	1/4 - 20
31834	31434	31633	1/2	.5002	2-1/4	1/4 - 20
31835	31435	31634	1/2	.5002	2-1/2	1/4 - 20
31836	31436	31635	1/2	.5002	3	1/4 - 20
31837	31437	31636	1/2	.5002	3-1/2	1/4 - 20
31838	31438	31637	1/2	.5002	4	1/4 - 20
31839	31439	31638	5/8	.6252	1-1/4	1/4 - 20
31840	31440	31639	5/8	.6252	1-1/2	1/4 - 20
31841	31441	31640	5/8	.6252	2	1/4 - 20
31842	31442	31641	5/8	.6252	2-1/4	1/4 - 20
31843	31443	31642	5/8	.6252	2-1/2	1/4 - 20
31844	31444	31643	5/8	.6252	3	1/4 - 20
31845	31445	31644	5/8	.6252	4	1/4 - 20
31846	31446	31645	3/4	.7502	1-1/2	5/16 - 18
31847	31456	31655	3/4	.7502	1-3/4	5/16 - 18
31848	31447	31646	3/4	.7502	2	5/16 - 18
31849	31448	31647	3/4	.7502	2-1/2	5/16 - 18
31850	31449	31648	3/4	.7502	3	5/16 - 18
31851	31450	31649	3/4	.7502	4	5/16 - 18
31856*	31451	31656	1	1.0002	1-3/4	5/16 - 18
31852*	31452	31650	1	1.0002	2	5/16 - 18
31853*	31453	31651	1	1.0002	2-1/2	5/16 - 18
31854*	31454	31652	1	1.0002	3	5/16 - 18
31855*	31455	31653	1	1.0002	4	5/16 - 18

*3/8-16 Internal Thread

Technical Data

Material:

Alloy Steel

Length Tolerance:

± .010"

Core Hardness:

47 - 58 Rockwell C

Diameter Tolerance:

± .0001"

Surface Hardness:

60 - 64 Rockwell C

Recommended Hole Size:

.0005" under Nom. Dia.

Surface Finish:

8 Micro-Inch

Specification:

ASME B18.8.2

Spiral Groove



Flat Vent



Standard Round



Special materials and sizes available upon request



Precision Ground Pull Dowels Stainless Steel

Spiral Groove	Standard Round	Nominal	Actual	Length	Internal Thread
31800-SS	31600-SS	1/4	.2502	1/2	8 - 32
31801-SS	31601-SS	1/4	.2502	3/4	8 - 32
31802-SS	31602-SS	1/4	.2502	1	8 - 32
31803-SS	31603-SS	1/4	.2502	1-1/4	8 - 32
31804-SS	31604-SS	1/4	.2502	1-1/2	8 - 32
31805-SS	31605-SS	1/4	.2502	1-3/4	8 - 32
31806-SS	31606-SS	1/4	.2502	2	8 - 32
31807-SS	31654-SS	1/4	.2502	2-1/4	8 - 32
31808-SS	31607-SS	1/4	.2502	2-1/2	8 - 32
31809-SS	31608-SS	5/16	.3127	3/4	10 - 32
31810-SS	31609-SS	5/16	.3127	1	10 - 32
31811-SS	31610-SS	5/16	.3127	1-1/4	10 - 32
31812-SS	31611-SS	5/16	.3127	1-1/2	10 - 32
31813-SS	31612-SS	5/16	.3127	2	10 - 32
31814-SS	31613-SS	5/16	.3127	2-1/4	10 - 32
31815-SS	31614-SS	5/16	.3127	2-1/2	10 - 32
31816-SS	31615-SS	3/8	.3752	3/4	10 - 32
31817-SS	31616-SS	3/8	.3752	1	10 - 32
31818-SS	31617-SS	3/8	.3752	1-1/4	10 - 32
31819-SS	31618-SS	3/8	.3752	1-1/2	10 - 32
31820-SS	31619-SS	3/8	.3752	1-3/4	10 - 32
31821-SS	31620-SS	3/8	.3752	2	10 - 32
31822-SS	31621-SS	3/8	.3752	2-1/4	10 - 32
31823-SS	31622-SS	3/8	.3752	2-1/2	10 - 32
31824-SS	31623-SS	3/8	.3752	3	10 - 32
31825-SS	31624-SS	7/16	.4377	1	1/4 - 20
31826-SS	31625-SS	7/16	.4377	1-1/2	1/4 - 20
31827-SS	31626-SS	7/16	.4377	2	1/4 - 20
31828-SS	31627-SS	1/2	.5002	3/4	1/4 - 20
31829-SS	31628-SS	1/2	.5002	1	1/4 - 20
31830-SS	31629-SS	1/2	.5002	1-1/4	1/4 - 20
31831-SS	31630-SS	1/2	.5002	1-1/2	1/4 - 20
31832-SS	31631-SS	1/2	.5002	1-3/4	1/4 - 20
31833-SS	31632-SS	1/2	.5002	2	1/4 - 20
31834-SS	31633-SS	1/2	.5002	2-1/4	1/4 - 20
31835-SS	31634-SS	1/2	.5002	2-1/2	1/4 - 20
31836-SS	31635-SS	1/2	.5002	3	1/4 - 20
31837-SS	31636-SS	1/2	.5002	3-1/2	1/4 - 20
31838-SS	31637-SS	1/2	.5002	4	1/4 - 20
31839-SS	31638-SS	5/8	.6252	1-1/4	1/4 - 20
31840-SS	31639-SS	5/8	.6252	1-1/2	1/4 - 20
31841-SS	31640-SS	5/8	.6252	2	1/4 - 20
31842-SS	31641-SS	5/8	.6252	2-1/4	1/4 - 20
31843-SS	31642-SS	5/8	.6252	2-1/2	1/4 - 20
31844-SS	31643-SS	5/8	.6252	3	1/4 - 20
31845-SS	31644-SS	5/8	.6252	4	1/4 - 20
31846-SS	31645-SS	3/4	.7502	1-1/2	5/16 - 18
31847-SS	31655-SS	3/4	.7502	1-3/4	5/16 - 18
31848-SS	31646-SS	3/4	.7502	2	5/16 - 18
31849-SS	31647-SS	3/4	.7502	2-1/2	5/16 - 18
31850-SS	31648-SS	3/4	.7502	3	5/16 - 18
31851-SS	31649-SS	3/4	.7502	4	5/16 - 18
31856-SS*	31656-SS	1	1.0002	1-3/4	5/16 - 18
31852-SS*	31650-SS	1	1.0002	2	5/16 - 18
31853-SS*	31651-SS	1	1.0002	2-1/2	5/16 - 18
31854-SS*	31652-SS	1	1.0002	3	5/16 - 18
31855-SS*	31653-SS	1	1.0002	4	5/16 - 18

*3/8-16 Internal Thread

Technical Data

Material:

300 Series SS (18-8)

Length Tolerance:

± .010"

Diameter Tolerance:

± .0001"

Recommended Hole Size:

.0005" under Nom. Dia.

Surface Finish:

8 Micro-Inch

Specification:

ASME B18.8.2

(Parts are not heat treated/hardened)

Spiral Groove



Standard Round



Special materials and sizes available upon request



Pull Dowels Metric



- Material: Low Carbon Steel
- Heat Treat: Case Hardened
- 3D Solid Models are available in multiple formats from www.jergensinc.com

Flat ground on the side for air release in blind holes.

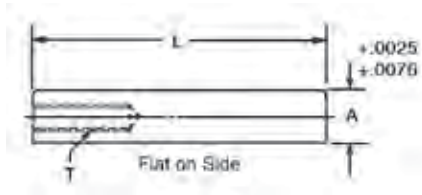

Part Number	A	L	T
31751	8	20	M5 x 1.0
31753	8	30	M5 x 1.0
31755	8	40	M5 x 1.0
31759	10	20	M6 x 1.0
31761	10	30	M6 x 1.0
31763	10	40	M6 x 1.0
31765	10	50	M6 x 1.0
31767	10	70	M6 x 1.0
31769	12	20	M6 x 1.0
31771	12	30	M6 x 1.0
31773	12	40	M6 x 1.0

Part Number	A	L	T
31775	12	50	M6 x 1.0
31776	12	60	M6 x 1.0
31777	12	70	M6 x 1.0
31780	16	40	M8 x 1.25
31782	16	50	M8 x 1.25
31783	16	60	M8 x 1.25
31784	16	70	M8 x 1.25
31787	20	50	M10 x 1.6
31788	20	60	M10 x 1.6
31789	20	70	M10 x 1.6

Button head screw not included.

Special materials and sizes available upon request



Rod Ends Threaded



- Material: Alloy Steel
- Finish: Black Oxide
- Heat Treat: 32-36 Rc
- Thread: Class 2A-UNC
- * 150,000 PSI Tensile

Rod Ends are forged and finished for applications not requiring flat contact with the head. All holes are reamed. Rod Ends can be used with spherical flange assemblies, flange nuts and clamp assemblies.

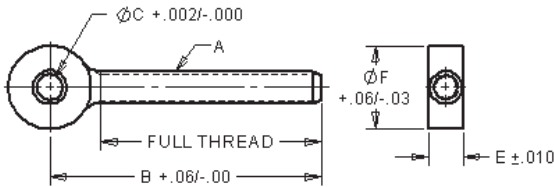

Part Number	Thread A	B	C	E	F	Wt. (lbs)
35301*	1/4-20	2	3/16	1/4	39/64	.04
35302	1/4-20	2	1/4	1/4	-	.03
35318*	5/16-18	3	1/4	5/16	43/64	.08
35319*	5/16-18	3	5/16	5/16	-	.08
35303*	3/8-16	3	5/16	3/8	13/16	.11
35320	3/8-16	4	5/16	3/8	-	.11
35304	3/8-16	2 3/16	3/8	3/8	-	.08
35305*	3/8-16	3	3/8	3/8	-	.11
35306*	3/8-16	5	3/8	3/8	-	.12
35307*	1/2-13	3 3/4	3/8	1/2	1 1/32	.25
35308	1/2-13	2 11/16	1/2	1/2	-	.19
35309	1/2-13	3 3/4	1/2	1/2	-	.24
35310	1/2-13	5	1/2	1/2	-	.31
35311	5/8-11	3 11/16	5/8	5/8	1 5/16	.40
35312*	5/8-11	4 1/2	5/8	5/8	-	.46
35314*	5/8-11	6	5/8	5/8	-	.60
35315*	3/4-10	4 1/2	3/4	3/4	1 9/16	.73
35321*	3/4-10	6	3/4	3/4	-	1.00
35317	1-8	8	1	1	2 3/32	2.25

*Conforms to TMCA.
Not to be used for lifting.

Rod Ends Stainless Steel



- Material: 303 Stainless
- Thread Class 2A-UNC

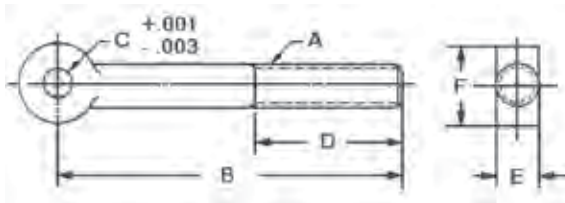

Part Number	Ref. A	B	Ref. C	D	E	F
35721	1/4-20	2 1/8	3/16	7/8	1/4	1/2
35722	1/4-20	2 1/8	1/4	7/8	1/4	1/2
35723	5/16-18	3 1/2	1/4	1 1/2	5/16	5/8
35724	5/16-18	3 1/2	5/16	1 1/2	5/16	5/8
35725	3/8-16	3 1/2	3/8	1 1/2	3/8	3/4
35726	3/8-16	5	3/8	2 1/2	3/8	3/4
35727	1/2-13	3 3/4	1/2	1 1/2	1/2	1
35728	1/2-13	5	1/2	2	1/2	1
35729	5/8-11	4 1/2	5/8	2	5/8	1 1/4
35730	5/8-11	6	5/8	3	5/8	1 1/4
35731	3/4-10	4 1/2	3/4	2	3/4	1 1/2
35732	3/4-10	6	3/4	2 1/2	3/4	1 1/2

Not to be used for lifting.

Special materials and sizes available upon request



Yokes Tapped



- Material: C-1021 Forging
- Finish: Black Oxide
- Thread: 2B

Jergens offers these yokes for attaching to threaded linkage at stem end. The forged holes are reamed and faced-off parallel inside and outside the yoke ends.

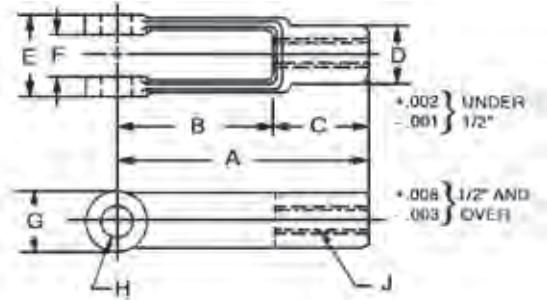

Part Number Coarse Pitch	UNC J	Part Number Fine Pitch	UNF J	A	B	C	D	E	F	G	H	Wt. (lbs) 10 Pcs.
		45501	10-32	1 9/16	1	9/16	5/16	7/16	3/16	3/8	3/16	.21
45302	1/4-20	45502	1/4-28	2	1 1/4	3/4	7/16	5/8	9/32	1/2	1/4	.62
45303	5/16-18	45503	5/16-24	2 1/4	1 7/16	13/16	1/2	3/4	11/32	19/32	5/16	.94
45304	3/8-16	45504	3/8-24	2 1/2	1 5/8	7/8	5/8	7/8	7/16	11/16	3/8	1.45
45305	7/16-14	45505	7/16-20	2 7/8	1 7/8	1	23/32	1	1/2	13/16	7/16	2.35
45306	1/2-13	45506	1/2-20	3	1 7/8	1 1/8	13/16	1 1/8	9/16	15/16	1/2	3.10
45307	1/2-13	45507	1/2-20	4 3/16	3 1/16	1 1/8	13/16	1 1/8	9/16	15/16	1/2	4.35
45308	5/8-11	45508	5/8-18	4 15/16	3 11/16	1 1/4	1 1/16	1 3/8	11/16	1 3/16	5/8	8.10
45309	3/4-10	45509	3/4-16	4	2 3/4	1 1/4	1 1/8	1 1/2	11/16	1 3/8	5/8	7.50
45310	3/4-10	—	—	6 1/16	4 9/16	1 1/2	1 1/4	1 5/8	13/16	1 7/16	3/4	15.00
45312	1-8	—	—	8	6	2	1 5/8	2 1/8	1 1/16	1 15/16	1	32.50

Yokes Threaded



- Material: C-1021 Forging
- Finish: Black Oxide
- Thread: 2A-UNC

This style yoke is similar to the above except the stem is threaded for attaching to tapped linkage.

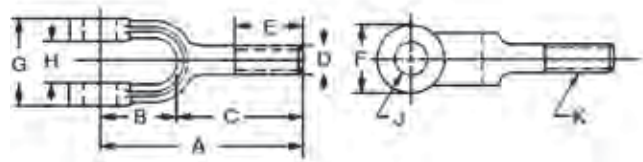

Part Number	K	A	B	C	D	E	F	G	H	J	Wt. (lbs) 10 Pcs.
45902	1/4-20	1 3/4	5/8	1 1/8	1/4	3/4	1/2	5/8	9/32	1/4	.47
45903	5/16-18	2	3/4	1 1/4	5/16	3/4	19/32	3/4	11/32	5/16	.85
45904	3/8-16	2 1/8	27/32	1 9/32	3/8	3/4	11/16	7/8	7/16	3/8	1.10
45906	1/2-13	2 1/2	1 1/8	1 3/8	1/2	3/4	15/16	1 1/8	9/16	1/2	2.35
45908	3/4-10	3 5/8	1 11/16	1 15/16	3/4	1 1/4	1 7/16	1 5/8	13/16	3/4	7.35
45910	1-8	4 1/2	2 1/2	2	1	1 1/8	1 15/16	2 1/8	1 1/16	1	17.50



Clevis Pins



- Material: Low Carbon Steel
- All Clevis Pins supplied with cotter pins.

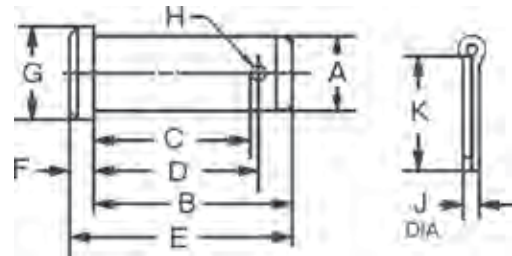

Part Number	A	B	C	D	E	F	G	H	J	K	Wt. (lbs) 10 Pcs.
32701	3/16	37/64	29/64	31/64	41/64	1/16	5/16	5/64	1/16	1/2	.08
32702	1/4	49/64	41/64	43/64	55/64	3/32	3/8	5/64	1/16	1/2	.15
32703	5/16	15/16	49/64	13/16	1 1/32	3/32	7/16	7/64	3/32	1/2	.30
32704	3/8	1 1/16	57/64	15/16	1 3/16	1/8	1/2	7/64	3/32	5/8	.45
32705	7/16	1 3/16	1 1/64	1 1/16	1 11/32	5/32	9/16	7/64	3/32	5/8	.60
32706	1/2	1 23/64	1 9/64	1 13/64	1 33/64	5/32	5/8	9/64	1/8	1	1.00
32707	5/8	1 39/64	1 25/64	1 29/64	1 13/16	13/64	13/16	9/64	1/8	1	1.18
32708	5/8	1 3/4	1 33/64	1 19/32	1 63/64	13/64	13/16	9/64	1/8	1	1.82
32709	3/4	1 29/32	1 41/64	1 23/32	2 5/32	1/4	15/16	11/64	5/32	1 1/2	3.00
32711	1	2 13/32	2 9/64	2 7/32	2 3/4	11/32	1 3/16	11/64	5/32	1 1/2	7.00



Leveling Mounts

- Material: 1214 Steel
- Zinc plated, yellow finish
- Non-Skid Material: Neoprene
- Case hardened, file hard

- Swivels 10° in all directions
- Available with non-skid on base
- Available in stainless steel, or with a delrin pad, and in larger sizes upon request.

Tapped

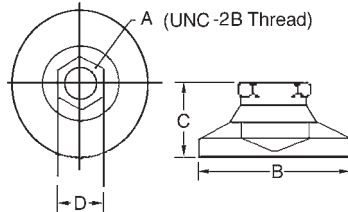

Part Number		A	B	C*	Across Flats D	Maximum Load (lbs)	
Standard	Non-skid					Standard	Non-skid
32601	32651	10-32	3/4	1 7/32	3/8	700	550
32602	32652	1/4-20	1	45/64	1/2	1000	825
32606	32656	3/8-16	1 1/4	7/8	5/8	3750	2820
32608	32658	1/2-13	1 7/8	1 1/8	3/4	5000	3750
32610	32660	5/8-11	2 1/2	1 1/4	7/8	6000	5000
32612	32662	3/4-10	3	1 1/2	1 1/16	7400	6000
32616	32666	1-8	4	1 7/8	1 3/8	21000	16500

*Add 1/8" to C Dimension for non-skid style.

Threaded

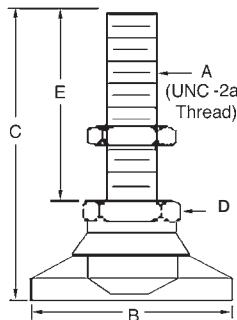

Part Number		A	B	C*	Across Flats D	E	Maximum Load (lbs)	
Standard	Non-skid						Standard	Non-skid
32621	32671	10-32	3/4	1 17/32	3/8	1	700	550
32623	32673	1/4-20	1	1 61/64	1/2	1 1/4	1000	825
32626	32676	3/8-16	1 1/4	2 7/8	5/8	2	3750	2850
32629	32679	1/2-13	1 7/8	3 1/8	3/4	2	5000	3750
32632	32682	5/8-11	2 1/2	3 1/4	7/8	2	6000	4350
32635	32685	3/4-10	3	3 1/2	1 1/16	2	7400	5500
32640	32690	1-8	4	5 3/8	1 3/8	3 1/2	20000	16500

*Add 1/8" to C Dimension for non-skid style.



USAE™ Heavy Duty Flat Washers



USS + SAE = USAE

What is a USAE™ Washer?

- It is a simple but effective idea that is long overdue.
- The Outside Diameter conforms to USS standards. This provides a washer that is up to 36% larger than standard hardened washers.

More Contact Area = More Holding Power

- The Inside Diameter conforms to SAE standards. The small ID provides a more precise fit on bolts, studs, etc.
- USAE Washers are also up to 37% thicker than standard hardened washers for greater strength.
- Washers are made from mild steel. They are case hardened to 60 HRc and have a black oxide finish.
- Bolt size is stamped on each washer for easy identification.

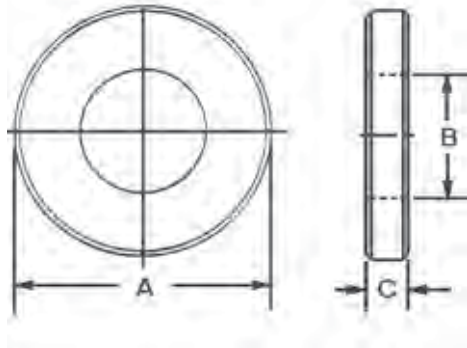

USAE™ Heavy Duty Flat Washers

Part No.	Bolt Size	A (OD)	B (ID)	C (Thickness)
FW00001	1/4	3/4	9/32	9/64
FW00002	5/16	7/8	11/32	9/64
FW00003	3/8	1	13/32	9/64
FW00004	1/2	1-3/8	17/32	5/32
FW00005	5/8	1-3/4	21/32	5/32
FW00006	3/4	2	13/16	1/4
FW00007	1	2-1/2	1-1/16	1/4

*Tolerances for all dimensions are +/- .010"

HANDWHEELS

Handwheels

Aluminum Angular Solid Handwheel.....	73
Aluminum Angular Spoked Handwheel.....	72
Aluminum Finger Wheel	80
Nylon Angular Three-Spoked Handwheel	79
Plastic Angular Solid Handwheel.....	79
Plastic Three-Spoked Handwheel	75
Plastic Three-Spoked Handwheel With Revolving Handle	76
Plastic Two-Spoked Handwheel	74
Plastic Two-Spoked Handwheel With Revolving Handles.....	74
Plastic Two-Spoked Handwheel With Revolving Fold-Away Handle	75
Plastic Solid Handwheel.....	78
Plastic Solid Handwheel With Finger Grips and Revolving Fold-Away Handle.....	79
Plastic Solid Handwheel With Revolving, Fold-Away Handle	77
Plastic Solid Handwheel With Revolving Handle	76
Plastic Solid Handwheel With Revolving, Spring Loaded, Fold-Away Handle	77



Aluminum Angular Spoked Handwheel



- Diameters from 4" to 23" and 100mm to 575mm
- Lightweight, 319 Aluminum Alloy
- Rims machined to run concentric with center drill
- Available with or without handle
- Special bores and keyways quoted upon request
- 3D Solid Models are available in multiple formats from www.jergensinc.com

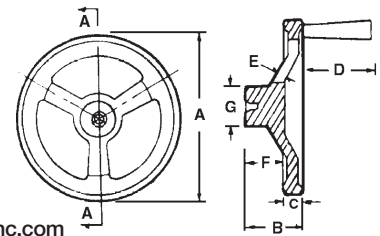

Handwheels With Handle

Part Number	A	B	C	D	E	F	G	Number Of Spokes
22308	4	1 1/2	5/8	1 5/8	1/4	1	1 3/16	2
22301	6	2	3/4	2 9/16	5/16	1 7/16	1 1/2	3
22302	8	2 1/2	7/8	2 15/16	3/8	1 7/8	2	3
22303	10	3	7/8	3 5/16	7/16	2 1/8	2 3/8	3
22304	12	3 3/8	7/8	3 5/16	7/16	2 3/16	2 1/2	3
22305	14	3 13/16	1	3 5/16	7/16	2 17/32	2 3/4	5
22306	18	4 7/8	1 1/4	3 5/16	7/16	3 1/16	4 1/8	5
22307	23	7 1/8	1 1/4	3 5/16	7/16	4 3/8	4 1/2	6

Part Number	
Handwheel Only	Handle Only
22108*	21902
22101*	21904
22102*	21905
22103*	21906
22104*	21906
22105*	21906
22106*	21906
22107*	21906

*Not tapped for handle

Metric Handwheels With Handle

Part Number	A	B	C	D	E	F	G	Number Of Spokes
22358	100	38	16	41	6	25	30	2
22351	150	50	19	64	8	36	38	3
22352	200	63	22	73	9	47	50	3
22353	250	75	22	83	11	53	59	3
22354	300	84	22	83	11	55	63	3
22355	350	95	25	83	11	63	69	5
22356	450	122	31	83	11	77	103	5
22357	575	178	31	83	11	110	113	6

Part Number	
Handwheel Only	Handle Only
22108*	21952
22101*	21954
22102*	21955
22103*	21956
22104*	21956
22105*	21956
22106*	21956
22107*	21956

*Not tapped for handle



Aluminum Angular Solid Handwheel



- Diameters from 3" to 12" and 75mm to 300mm
- Lightweight, 319 Aluminum Alloy
- Rims machined to run concentric with center drill
- Available with or without handle
- Special bores and keyways quoted upon request
- 3D Solid Models are available in multiple formats from www.jergensinc.com

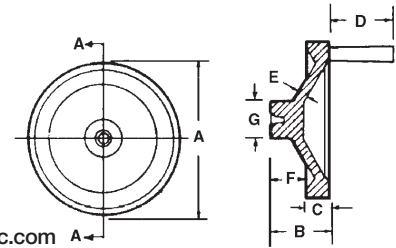

Handwheels With Handle

Part Number	A	B	C	D	E	F	G
22702	3	1 11/16	5/8	1 5/8	1/4	1 7/32	1 1/4
22703	4	1 7/8	5/8	1 5/8	3/16	1 7/16	1 1/2
22704	5	2	11/16	2 1/16	3/16	1 1/4	1 1/2
22705†	6	2	3/4	2 9/16	3/16	1 3/8	1 1/2
22706†	8	2 1/2	7/8	2 15/16	3/16	1 3/4	2
22707†	10	3 1/4	1	3 5/16	3/16	2 7/32	2 5/16
22708†	12	3 1/2	1	3 5/16	1/4	2 1/4	2 1/2

†Finger grips formed behind solid wheel rim

Part Number	
Handwheel Only	Handle Only
22502*	21902
22503*	21902
22504*	21903
22505†	21904
22506†	21905
22507†	21906
22508†	21906

*Not tapped for handle

Metric Handwheels With Handle

Part Number	A	Ref. B	C	D	E	F	G
22752	75	42	16	41	6	30	31
22753	100	47	16	41	5	36	38
22754	125	50	17	52	5	31	38
22755	150	50	19	64	5	34	38
22756	200	63	22	73	5	44	50
22757	250	81	25	83	5	55	58
22758	300	88	25	83	6	56	63

*Not tapped for handle

Part Number	
Handwheel Only	Handle Only
22502*	21952
22503*	21952
22504*	21953
22505*	21954
22506*	21955
22507*	21956
22508*	21956



Plastic Two-Spoked Handwheel ELESA Original Design



- Material: High Impact Strength Technopolymer
- Finish: Black Matte
- Hub: Black Oxide Steel
- Special bores and keyways quoted upon request
- Resistant to Solvents, Oils, Greases, and other Chemical Agents

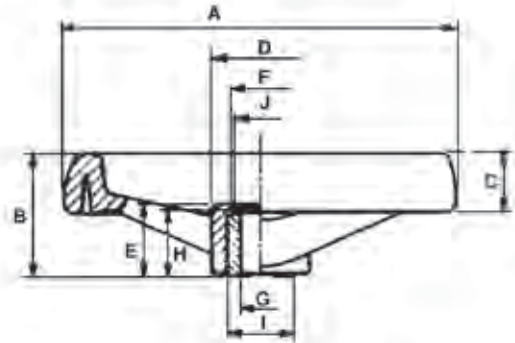

Handwheels Only

Part Number	A	B	C	D	E	F	Fractional G	H	I	J
22601	3.15	1.38	0.71	0.91	0.75	0.67	5/16	0.67	0.71	0.62
22602	3.90	1.46	0.79	0.98	0.75	0.67	3/8	0.67	0.71	0.63
22603	4.92	1.73	0.87	1.22	0.98	0.83	3/8	0.87	0.87	0.79
22604	6.30	2.01	0.98	1.57	1.14	0.98	1/2	1.06	1.02	0.94
22605	7.87	2.40	1.10	1.97	1.42	1.22	5/8	1.34	1.18	1.10
22606	9.84	2.76	1.26	2.32	1.57	1.34	5/8	1.50	1.32	1.30
22607	11.81	3.07	1.42	2.60	1.81	1.65	3/4	1.69	1.57	1.46
22608	14.76	3.23	1.50	2.72	1.81	1.65	3/4	1.69	1.57	1.46

Plastic Two-Spoked Handwheel With Revolving Handles ELESA Original Design



- Material: High Impact Strength Technopolymer
- Finish: Black Matte
- Hub: Black Oxide Steel
- Special bores and keyways quoted upon request
- Resistant to Solvents, Oils, Greases, and other Chemical Agents

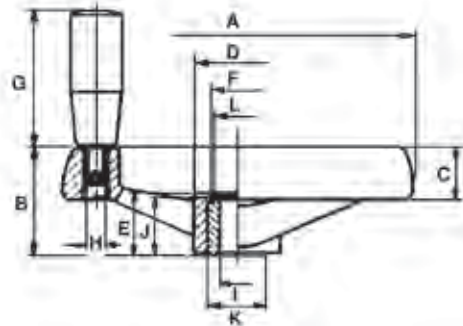

Handwheels With Revolving Handle

Part Number	A	B	C	D	E	F	G	H	I	J	K	L
22611	3.15	1.38	0.71	0.91	0.75	0.67	1.57	M6	0.312	0.67	0.71	0.63
22612	3.90	1.46	0.79	0.98	0.75	0.67	2.20	M6	0.375	0.67	0.71	0.63
22613	4.92	1.73	0.87	1.22	0.98	0.83	2.56	M8	0.375	0.87	0.87	0.79
22614	6.30	2.01	0.98	1.57	1.14	0.98	2.56	M8	0.500	1.06	1.02	0.94
22615	7.87	2.40	1.10	1.97	1.42	1.22	3.15	M8	0.625	1.34	1.18	1.10
22616	9.84	2.76	1.26	2.32	1.57	1.34	3.54	M10	0.625	1.50	1.38	1.30
22617	11.81	3.07	1.42	2.60	1.81	1.65	3.54	M10	0.750	1.69	1.57	1.46
22618	14.76	3.23	1.50	2.72	1.81	1.65	3.54	M10	0.750	1.69	1.57	1.46



Plastic Two-Spoked Handwheel With Revolving Fold-Away Handle ELESA Original Design



- Material: High Impact Strength Technopolymer
- Finish: Black Matte
- Hub: Black Oxide Steel
- Special bores and keyways quoted upon request
- Resistant to Solvents, Oils, Greases, and other Chemical Agents

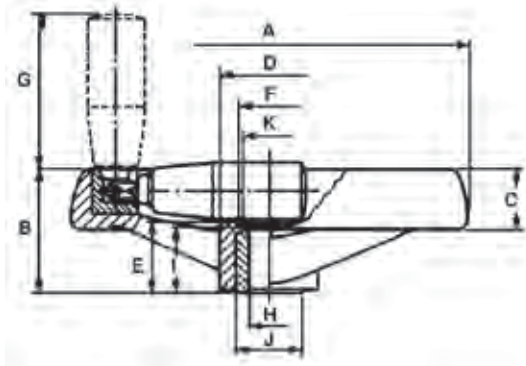

Part Number	A	B	C	D	E	F	G	H	I	J	K
22621	3.15	1.38	.71	.91	.75	.67	1.96	.312	.67	.71	.62
22622	3.90	1.46	.79	.98	.75	.67	2.20	.375	.67	.71	.63
22623	4.92	1.73	.87	1.22	.98	.83	2.56	.375	.87	.87	.79
22624	6.30	2.01	.98	1.57	1.14	.98	2.56	.500	1.06	1.02	.94
22625	7.87	2.40	1.10	1.97	1.42	1.22	3.15	.625	1.34	1.18	1.10
22626	9.84	2.76	1.26	2.32	1.57	1.34	3.54	.625	1.50	1.38	1.30

Plastic Three-Spoked Handwheel ELESA Original Design



- Material: High Strength Reinforced Duroplast
- Finish: Black Bright
- Hub: Black Oxide Steel
- Special bores and keyways quoted upon request
- Resistant to Solvents, Oils, Greases, and other Chemical Agents

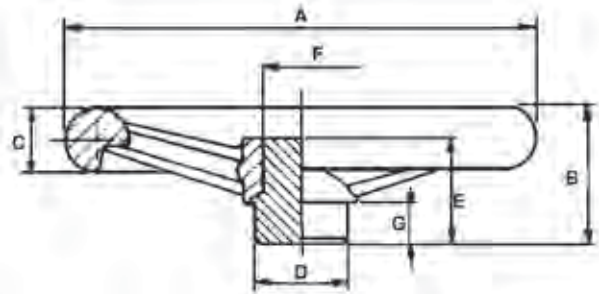

Part Number	A	B	C	D	E	F	G
22631	3.86	1.57	.55	.94	1.42	.79	.47
22632	4.88	1.77	.71	.94	1.42	.79	.47
22633	6.18	1.97	.87	1.26	1.50	.94	.59
22634	7.09	2.20	.94	1.57	1.69	1.22	.59
22635	7.80	2.20	.94	1.57	1.69	1.22	.59
22636	9.72	2.60	1.18	1.93	1.73	1.50	.59
22637	11.34	3.07	1.26	2.28	2.20	1.85	.71
22638	14.76	4.25	1.57	2.28	3.03	2.28	1.02



Plastic Three-Spoked Handwheel With Revolving Handle ELESA Original Design



- Material: High Strength Reinforced Duroplast
- Finish: Black Bright
- Hub: Black Oxide Steel
- Special bores and keyways quoted upon request
- Resistant to Solvents, Oils, Greases, and other Chemical Agents

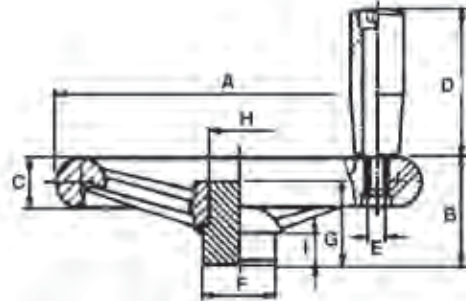

Part Number	A	B	C	D	E	F	G	H	I
22641	3.86	1.57	.55	1.57	M6	.94	1.42	.79	.47
22642	4.88	1.77	.71	1.97	M8	.94	1.42	.79	.47
22643	6.18	1.97	.87	2.56	M8	1.26	1.50	.94	.59
22644	7.09	2.20	.94	3.15	M10	1.57	1.69	1.22	.59
22645	7.80	2.20	.94	3.15	M10	1.57	1.69	1.22	.59
22646	9.72	2.60	1.18	3.54	M10	1.93	1.73	1.50	.59
22647	11.34	3.07	1.26	3.94	M12	2.28	2.20	1.85	.71
22648	14.76	4.25	1.57	3.94	M14	2.28	3.03	2.28	1.02

Plastic Solid Handwheel With Revolving Handle ELESA Original Design



- Material: High Impact Strength Technopolymer
- Finish: Black Matte
- Hub: Black Oxide Steel
- Special bores and keyways quoted upon request
- Resistant to Solvents, Oils, Greases, and other Chemical Agents

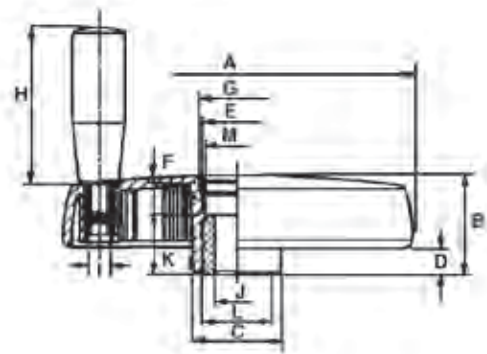

Part Number	A	B	C	D	E	F	G	H	I	J	K	L	M
22801	3.27	1.14	.98	.35	.75	.31	.82	1.57	M6	.312	.67	.71	.63
22802	4.02	1.34	1.18	.39	.98	.35	1.06	1.97	M6	.375	.87	.87	.79
22803	4.92	1.54	1.38	.43	1.10	.31	1.22	2.20	M6	.375	1.06	1.02	.94
22804	5.91	1.73	1.50	.47	1.18	.39	1.34	2.56	M8	.500	1.18	1.02	.94
22805	6.93	1.93	1.73	.51	1.38	.63	1.54	3.15	M10	.500	1.10	1.38	1.30
22806	7.87	2.09	1.97	.55	1.57	.51	1.73	3.54	M10	.625	1.42	1.57	1.50
22807	9.84	2.36	2.24	.66	1.88	.75	1.97	3.54	M10	.625	1.42	1.57	1.50



Plastic Solid Handwheel With Revolving, Fold-Away Handle ELESA Original Design



- Material: High Impact Strength Technopolymer
- Finish: Black Matte
- Hub: Black Oxide Steel
- Special bores and keyways quoted upon request
- Resistant to Solvents, Oils, Greases, and other Chemical Agents

This type of handwheel with fold-away handle has been designed for applications where limited space or safety reasons demand that the handle be folded back flat after manual use.

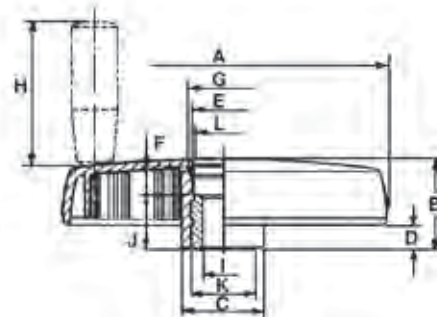

Part Number	A	B	C	D	E	F	G	H	I	J	K	L
22811	3.27	1.50	0.98	0.73	0.53	0.14	0.65	1.77	0.312	0.67	0.71	0.63
22812	4.02	1.34	1.18	0.39	0.98	0.35	1.06	1.97	0.375	0.87	0.87	0.79
22813	4.92	1.54	1.38	0.43	1.10	0.31	1.22	2.20	0.375	1.06	1.02	0.94
22814	5.91	1.73	1.50	0.47	1.18	0.39	1.34	2.56	0.50	1.18	1.02	0.94
22815	6.93	1.93	1.73	0.51	1.38	0.63	1.54	3.15	0.50	1.10	1.38	1.30
22816	7.87	2.09	1.97	0.55	1.57	0.51	1.73	3.54	0.625	1.42	1.57	1.50
22817	9.84	2.36	2.24	0.66	1.88	0.74	1.97	3.54	0.625	1.42	1.57	1.50

Plastic Solid Handwheel With Revolving, Spring Loaded, Fold-Away Handle ELESA Original Design



- Material: High Impact Strength Technopolymer
- Finish: Black Matte
- Hub: Black Oxide Steel
- Special bores and keyways quoted upon request
- Resistant to Solvents, Oils, Greases, and other Chemical Agents

This handwheel has a special spring loaded handle which automatically folds down into the cavity of the handwheel when the operator releases it. The handle disengages only when the axial pressure exerted by the operator ceases.

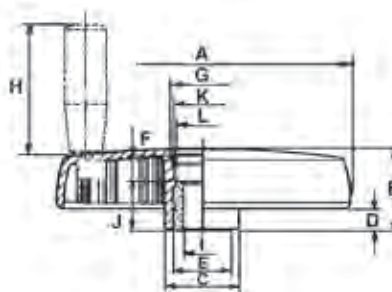

Part Number	A	B	C	D	E	F	G	H	I	J	K	L
22825	6.93	1.93	1.73	.51	1.38	.63	1.54	3.15	.500	1.10	1.38	1.30
22826	7.87	2.09	1.97	.55	1.57	.51	1.75	3.54	.625	1.42	1.57	1.50
22827	9.84	2.36	2.24	.66	1.88	.74	1.96	3.54	.625	1.42	1.57	1.50



Plastic Solid Handwheel ELESA Original Design



- Material: High Strength Reinforced Duroplast
- Finish: Black Bright
- Hub: Black Oxide Steel
- Special bores and keyways quoted upon request
- Resistant to Solvents, Oils, Greases, and other Chemical Agents

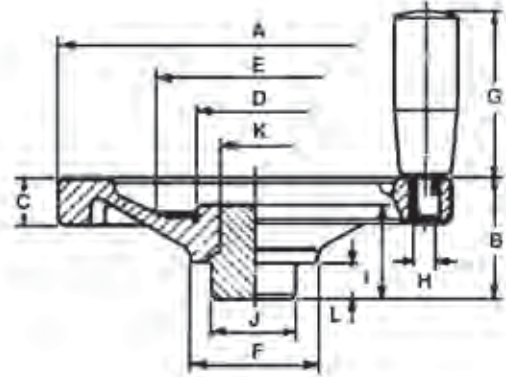

Part Number	A	B	C	D	E	F	G	H	I	J	K	L
22831	3.15	1.22	0.55	1.10	1.69	1.18	—	—	1.10	0.79	0.71	0.39
22841*	3.15	1.22	0.55	1.10	1.69	1.18	1.57	M6	1.10	0.79	0.71	0.39
22832	3.94	1.57	0.59	1.38	2.13	1.54	—	—	1.42	0.94	0.87	0.47
22842*	3.94	2.01	1.02	1.38	2.13	1.54	1.97	M6	1.42	0.94	0.79	0.47
22833	4.92	1.73	0.59	1.73	2.76	1.81	—	—	1.50	1.26	1.04	0.59
22843*	4.92	2.24	1.10	1.73	2.76	1.81	2.56	M8	1.50	1.26	0.96	0.59
22834	5.91	2.40	1.18	1.97	3.14	1.89	—	—	1.50	1.26	1.04	0.59
22844*	5.91	2.36	1.18	1.97	3.15	1.89	2.56	M8	1.50	1.26	0.96	0.59
22835	6.89	2.13	0.75	2.17	3.54	2.20	—	—	1.69	1.57	1.30	0.59
22845*	6.89	2.60	1.26	2.17	3.54	2.20	3.15	M10	1.69	1.57	1.22	0.59
22836	7.87	2.28	0.83	2.17	3.54	2.36	—	—	1.69	1.57	1.30	0.59
22846*	7.87	2.68	1.26	2.17	3.54	2.36	3.54	M10	1.69	1.57	1.22	0.59
22837	9.80	2.56	0.98	2.60	4.33	2.76	—	—	1.73	1.93	1.57	0.59
22847*	9.80	2.95	1.42	2.60	4.33	2.76	3.54	M10	1.73	1.93	1.50	0.59
22838	11.85	2.95	0.98	3.70	5.83	3.23	—	—	2.20	2.28	2.28	0.71
22848*	11.85	3.43	1.42	3.70	5.83	3.23	3.54	M10	2.20	2.28	2.28	0.71

* With Revolving Handle

Jergens offers 3D models

for all handles, knobs and handwheels
at www.jergensinc.com



Plastic Solid Handwheel With Finger Grips and Revolving Fold-Away Handle ELESA Original Design



- Material: High Strength Reinforced Duroplast
- Finish: Black Bright
- Hub: Black Oxide Steel
- Special bores and keyways quoted upon request
- Resistant to Solvents, Oils, Greases, and other Chemical Agents

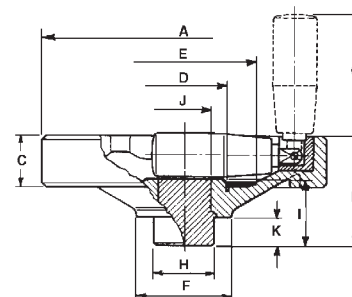

Part Number	A	B	C	D	E	F	G	H	I	J	K
22852	3.94	2.01	1.02	1.38	2.13	1.54	2.20	0.94	1.32	0.79	0.47
22853	4.92	2.24	1.10	1.73	2.76	1.81	2.56	1.26	1.50	1.00	0.59
22854	5.91	2.36	1.18	1.97	3.15	1.89	2.56	1.26	1.50	0.96	0.59
22855	6.89	2.60	1.26	2.17	3.54	2.20	3.15	1.57	1.69	1.22	0.59
22856	7.87	2.68	1.26	2.17	3.54	2.36	3.54	1.57	1.69	1.22	0.59
22857	9.80	2.95	1.42	2.60	4.33	2.76	3.54	1.93	1.73	1.50	0.59

Nylon Angular Three-Spoked Handwheel



- Material: Wheel, 6-6 Nylon
Hub, Cast Iron
- Finish: Wheel, Black
Hub, Black Oxide
- Threaded Brass Inserts have serrated O.D. for rigid union with Handwheel.
- All Wheels have three spokes
- Special bores and keyways quoted upon request
- 3D Solid Models are available in multiple formats from www.jergensinc.com

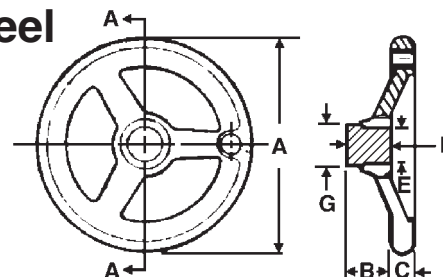

Part Number	A	B	C	E	F	G	Thread Size
34051	4	1 3/32	9/16	15/16	15/16	1 1/16	M8 x 1.25
34054	6	1 13/32	23/32	1 3/16	1 3/8	1 3/8	M10 x 1.50
34055	8	1 13/32	7/8	1 3/8	1 29/32	1 17/32	M10 x 1.50

Plastic Angular Solid Handwheel



- Material: Wheel, Acetal Co-Polymer
Hub, Cast Iron
- Finish: Wheel, Black
Hub, Black Oxide
- Threaded Brass Inserts have serrated O.D. for rigid union with Handwheel.
- Aluminum Center Plate can be imprinted with your company name, instructions, etc.
- Special bores and keyways quoted upon request
- 3D Solid Models are available in multiple formats from www.jergensinc.com

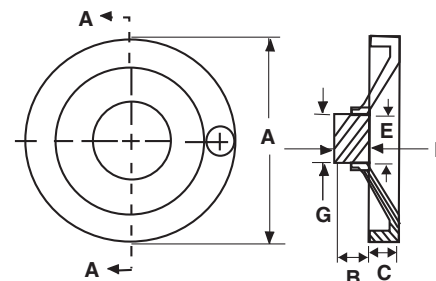

Part Number	A	B	C	E	F	G	Thread Size
34061	5	1 1/8	5/8	1	1 1/8	1 1/8	M8 x 1.25
34062	6	1 11/32	23/32	1 3/16	1 11/32	1 11/32	M10 x 1.50
34063	8	1 29/32	25/32	1 3/8	1 29/32	1 17/32	M10 x 1.50

HANDWHEELS



Aluminum Finger Wheel



- Material: 2024 Aluminum
- Finish: Black Anodize
- Knurled O.D. for better gripping
- Revolving handle and reamed hole are included
- Special bores and keyways quoted upon request
- 3D Solid Models are available in multiple formats from www.jergensinc.com

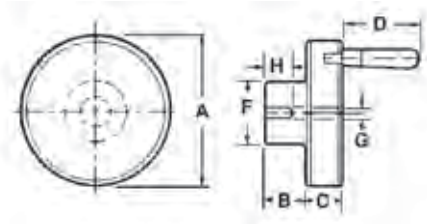

Finger Wheel With Handle

Part Number	A	B	C	D	F	G	H	Part Number	
								Wheel Only	Handle Only
22721	2	9/16	9/16	1 1/8	13/16	3/8	7/8	22521	21911

Metric Finger Wheel With Handle

Part Number	A	B	C	D	F	G	H	Part Number	
								Wheel Only	Handle Only
22771	50	14	14	28	20	10	22	22571*	21951

*Not tapped for handle

Aluminum Finger Wheel

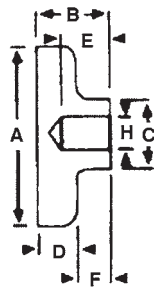

- Material: 2024 Aluminum
- Finish: Clear anodized polished to a high luster
- Special bores and keyways quoted upon request
- Outer rim is knurled

Finger Wheels

Part Number	A	B	C	D	E	F	H
21280	1	13/16	1/2	3/8	—	7/16	Blank
21281	2	1 1/8	13/16	9/16	—	9/16	Blank
21282	3	1 1/4	1 1/4	11/16	—	9/16	Blank
21285	1	13/16	1/2	3/8	5/8	7/16	1/4
21286	2	1 1/8	13/16	9/16	7/8	9/16	3/8
21287	3	1 1/4	1 1/4	11/16	7/8	9/16	5/8

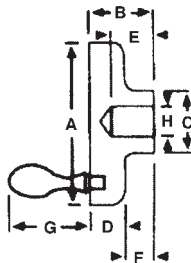

Finger Wheels With Handle

Part Number	A	B	C	D	E	F	G	H
21291	2	1 1/8	13/16	9/16	—	9/16	1 9/32	Blank
21292	3	1 1/4	1 1/4	9/16	—	9/16	1 15/16	Blank
21296	2	1 1/8	13/16	9/16	7/8	9/16	1 9/32	3/8
21297	3	1 1/4	1 1/4	9/16	7/8	9/16	1 15/16	5/8

Note: Also available in Stainless Steel

HANDLES, LEVERS & CRANKS

Handles, Levers & Cranks

Adjustable Handle.....	106	Plastic Button Head Adjustable Tapped Handle With Stainless Steel Insert	108
Adjustable Handle With Stud.....	106	Plastic Crank With Revolving Fold-Away Handle.....	97
Aluminum Balanced Crank Handle.....	99	Plastic Crank With Revolving Handle	97
Aluminum Revolving and Solid Handle.....	82	Plastic Folding Handle.....	82
Aluminum Tubular Handle	113	Plastic Fixed Handle.....	82
Aluminum & Malleable Clamping Levers	102	Plastic Handle.....	112
Aluminum & Malleable Offset Handle.....	101	Plastic Heavy Duty Tapered Handle	95
Aluminum & Malleable Speed Handle	98	Plastic Light Duty Tapered Handle	95
Back Mounted Bridge Handle	111	Plastic Pull/Lift Handle	113
Balanced Crank Handle.....	99	Plastic Revolving Fold-Away Handle	96
Cam Levers Adjustable External Thread	85	Plastic Revolving Heavy Duty Handle With Steel Shank	93
Cam Levers Adjustable Plastic External Thread	91	Plastic Revolving Handle With Steel Through Shank	93
Cam Levers Adjustable Stainless Steel External Thread	90	Plastic Revolving Handle With Steel Shank.....	94
Cam Levers External Thread	83-86	Revolving Handle	94
Cam Levers Plastic External Thread.....	88	Single Handle Locking Lever.....	101
Cam Levers Plastic Internal Thread	89	Steel Clamp Lever.....	100
Cam Levers Stainless Steel External Thread	86	Steel Solid and Revolving Balanced Crank Handle.....	99
Cam Levers Stainless Steel Internal Thread	87		
Control Lever.....	110		
Double Handle Locking Lever	102		
Ergonomic Style Steel Handles.....	92		
Fold-Away Handle	96		
Forged Crank Handle.....	100		
Front Mounted Bridge Handle.....	111		
Handle With Steel Shank	93		
Machine Guard Handles.....	110		
Metal Adjustable Handles	103-105		
Plastic Adjustable Handle With Stainless Steel Stud	108		
Plastic Button Head Tapped Adjustable Handle	107, 109		
Plastic Button Head Adjustable Handle With Stud	107, 109		



MANUFACTURING EFFICIENCY



Aluminum Revolving and Solid Handle

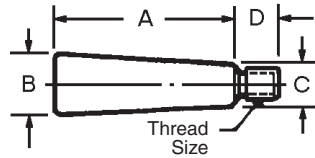

- Material: Handle, 2024 Aluminum
Stem, Low Carbon Steel
- Finish: Revolving Handle, Clear or Black Anodize
Stem for Revolving Handle, Zinc Plate
Solid Handle, Plain
- 3D Solid Models are available in multiple formats
from www.jergensinc.com

Aluminum Revolving Handles

Part Number		A	B	C	D	Thread Size	Wt. (lbs)
Clear	Black						
21901	21911	1 1/8	7/16	3/8	3/8	10-24	.02
21902	21912	1 9/16	5/8	1/2	7/16	1/4-20	.03
21903	21913	2	7/8	9/16	1/2	5/16-18	.08
21904	21914	2 1/2	1	3/4	1/2	3/8-16	.19
21905	21915	2 7/8	1 1/8	15/16	1/2	1/2-13	.23
21906	21916	3 1/4	1 1/4	15/16	1/2	1/2-13	.39

Solid Handles

Part Number	Wt. (lbs)
—	—
10301	.03
10302	.10
10303	.15
—	—
10304	.31

Metric

Clear	Black	A	B	C	D	Thread Size
Part Number*						
21951	21961	28	11	9	9	M5
21952	21962	39	16	13	11	M6
21953	21963	50	22	14	13	M8
21954	21964	63	25	19	13	M10
21955	21965	72	28	23	13	M12
21956	21966	82	31	23	13	M12

*Dimensions in millimeters

- Material: Handles: 2024 Aluminum
Stem: Low Carbon Steel
- Finish: Clear or Black Anodize
Stem: Zinc Plate
- Thread: Class 6g

Plastic Folding Handle

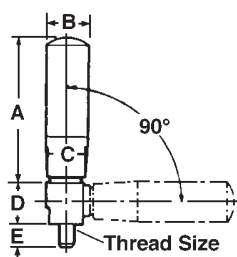

- Material: Handle, 6-6 Nylon Stem, Steel
- Finish: Handle, Black Stem, Chrome Plated
- Folds out of the way
- 3D Solid Models are available in multiple formats from www.jergensinc.com

Part Number	A	B	C	D	E	Thread Size
34070	2 1/4	25/32	25/32	7/8	1/2	M8 x 1.25
34071	3	25/32	25/32	7/8	9/16	M10 x 1.50

Plastic Fixed Handle

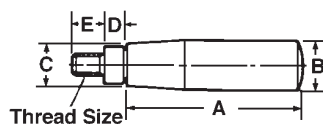

- Material: Handle, 6-6 Nylon Stem, Steel
- Finish: Handle, Black Stem, Chrome Plated
- 3D Solid Models are available in multiple formats from www.jergensinc.com

Part Number	A	B	C	D	E	Thread Size
34075	2 9/32	5/8	9/16	5/16	1/2	M8 x 1.25
34076	2 15/32	7/8	11/16	23/32	9/16	M10 x 1.50



Cam Levers

External Thread, Inch

- High quality industrial cam lever for clamping and quick change applications
- The external thread version features a threaded stud pinged to the hinge pin for tool-less clamping. The internal thread version features a threaded hinge pin for attachment to an existing threaded stud.
- Available in inch or metric threads
- Cast aluminum handle, powder-coated in black
- Threaded components and washer in steel, trivalent blue passivated, or stainless steel
- Fiberglass reinforced plastic thrust washer

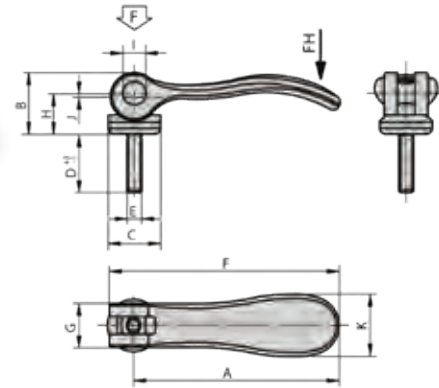

INCH, EXTERNAL		A	B	C	D	E	F	G	H	I	STROKE J	K	CLAMPING FORCE (lb-ft)	HAND FORCE lbf
STEEL	S.S.													
40015	41015	1.43	0.51	0.47	0.39	6-32	1.64	0.45	0.35	0.24	0.04	0.57	1106	20
40016	41016	1.43	0.51	0.47	0.59	6-32	1.64	0.45	0.35	0.24	0.04	0.57	1106	20
40017	41017	1.43	0.51	0.47	1.18	6-32	1.64	0.45	0.35	0.24	0.04	0.57	1106	20
40018	41018	1.43	0.51	0.47	0.39	8-32	1.64	0.45	0.35	0.24	0.04	0.57	1106	20
40019	41019	1.43	0.51	0.47	0.59	8-32	1.64	0.45	0.35	0.24	0.04	0.57	1106	20
40020	41020	1.43	0.51	0.47	1.18	8-32	1.64	0.45	0.35	0.24	0.04	0.57	1106	20
40021	41021	2.06	0.67	0.61	0.59	8-32	2.33	0.51	0.44	0.32	0.04	0.71	1843	22
40022	41022	2.06	0.67	0.61	0.79	8-32	2.33	0.51	0.44	0.32	0.04	0.71	1843	22
40023	41023	2.06	0.67	0.61	1.18	8-32	2.33	0.51	0.44	0.32	0.04	0.71	1843	22
40024	41024	2.06	0.67	0.61	0.79	10-24	2.33	0.51	0.44	0.32	0.04	0.71	1843	22
40025	41025	2.06	0.67	0.61	1.18	10-24	2.33	0.51	0.44	0.32	0.04	0.71	1843	22
40026	41026	2.06	0.67	0.61	1.57	10-24	2.33	0.51	0.44	0.32	0.04	0.71	1843	22
40027	41027	2.06	0.67	0.61	1.97	10-24	2.33	0.51	0.44	0.32	0.04	0.71	1843	22
40028	41028	2.06	0.67	0.61	0.79	10-32	2.33	0.51	0.44	0.32	0.04	0.71	1843	22
40029	41029	2.06	0.67	0.61	1.18	10-32	2.33	0.51	0.44	0.32	0.04	0.71	1843	22
40030	41030	2.06	0.67	0.61	1.57	10-32	2.33	0.51	0.44	0.32	0.04	0.71	1843	22
40031	41031	2.06	0.67	0.61	1.97	10-32	2.33	0.51	0.44	0.32	0.04	0.71	1843	22
40032	41032	2.77	0.87	0.71	0.79	10-32	3.12	0.59	0.57	0.35	0.05	0.85	2950	26
40033	41033	2.77	0.87	0.71	1.18	10-32	3.12	0.59	0.57	0.35	0.05	0.85	2950	26
40034	41034	2.77	0.87	0.71	1.57	10-32	3.12	0.59	0.57	0.35	0.05	0.85	2950	26
40035	41035	2.77	0.87	0.71	1.97	10-32	3.12	0.59	0.57	0.35	0.05	0.85	2950	26
40036	41036	2.77	0.87	0.71	0.79	1/4/20	3.12	0.59	0.57	0.35	0.05	0.85	2950	26
40037	41037	2.77	0.87	0.71	1.18	1/4/20	3.12	0.59	0.57	0.35	0.05	0.85	2950	26
40038	41038	2.77	0.87	0.71	1.57	1/4/20	3.12	0.59	0.57	0.35	0.05	0.85	2950	26
40039	41039	2.77	0.87	0.71	1.97	1/4/20	3.12	0.59	0.57	0.35	0.05	0.85	2950	26
40040	41040	3.78	1.12	1.07	0.98	5/16-18	4.25	0.94	0.71	0.43	0.06	1.31	5900	78
40041	41041	3.78	1.12	1.07	1.18	5/16-18	4.25	0.94	0.71	0.43	0.06	1.31	5900	78
40042	41042	3.78	1.12	1.07	1.57	5/16-18	4.25	0.94	0.71	0.43	0.06	1.31	5900	78
40043	41043	3.78	1.12	1.07	1.97	5/16-18	4.25	0.94	0.71	0.43	0.06	1.31	5900	78
40044	41044	3.78	1.12	1.07	0.98	3/8-16	4.25	0.94	0.71	0.43	0.06	1.31	5900	78
40045	41045	3.78	1.12	1.07	1.18	3/8-16	4.25	0.94	0.71	0.43	0.06	1.31	5900	78
40046	41046	3.78	1.12	1.07	1.57	3/8-16	4.25	0.94	0.71	0.43	0.06	1.31	5900	78
40047	41047	3.78	1.12	1.07	1.97	3/8-16	4.25	0.94	0.71	0.43	0.06	1.31	5900	78

HANDLES, LEVERS & CRANKS



Cam Levers

External Thread, Metric

- High quality industrial cam lever for clamping and quick change applications
- The external thread version features a threaded stud pinged to the hinge pin for tool-less clamping. The internal thread version features a threaded hinge pin for attachment to an existing threaded stud.
- Available in inch or metric threads
- Cast aluminum handle, powder-coated in black
- Threaded components and washer in steel, trivalent blue passivated, or stainless steel
- Fiberglass reinforced plastic thrust washer

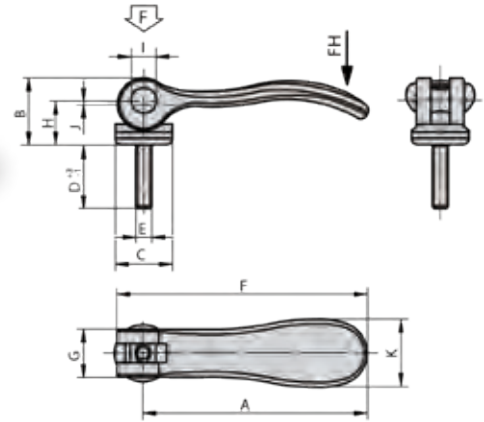

METRIC, EXTERNAL		A	B	C	D	E	F	G	H	I	STROKE J	K	CLAMPING FORCE (kN)	HAND FORCE N
STEEL	S.S.													
40048	41048	36.2	13	12	10	M3	41.7	11.5	9	6	1	14.4	1.5	90
40049	41049	36.2	13	12	15	M3	41.7	11.5	9	6	1	14.4	1.5	90
40050	41050	36.2	13	12	30	M3	41.7	11.5	9	6	1	14.4	1.5	90
40051	41051	36.2	13	12	10	M4	41.7	11.5	9	6	1	14.4	1.5	90
40052	41052	36.2	13	12	15	M4	41.7	11.5	9	6	1	14.4	1.5	90
40053	41053	36.2	13	12	30	M4	41.7	11.5	9	6	1	14.4	1.5	90
40054	41054	52.3	17	15.4	15	M4	59.1	13	11.2	8	1	18	2.5	100
40055	41055	52.3	17	15.4	20	M4	59.1	13	11.2	8	1	18	2.5	100
40056	41056	52.3	17	15.4	30	M4	59.1	13	11.2	8	1	18	2.5	100
40057	41057	52.3	17	15.4	20	M5	59.1	13	11.2	8	1	18	2.5	100
40058	41058	52.3	17	15.4	30	M5	59.1	13	11.2	8	1	18	2.5	100
40059	41059	52.3	17	15.4	40	M5	59.1	13	11.2	8	1	18	2.5	100
40060	41060	52.3	17	15.4	50	M5	59.1	13	11.2	8	1	18	2.5	100
40061	41061	70.4	22	18.1	20	M5	79.2	15	14.5	9	1.2	21.5	4	120
40062	41062	70.4	22	18.1	30	M5	79.2	15	14.5	9	1.2	21.5	4	120
40063	41063	70.4	22	18.1	40	M5	79.2	15	14.5	9	1.2	21.5	4	120
40064	41064	70.4	22	18.1	50	M5	79.2	15	14.5	9	1.2	21.5	4	120
40065	41065	70.4	22	18.1	20	M6	79.2	15	14.5	9	1.2	21.5	4	120
40066	41066	70.4	22	18.1	30	M6	79.2	15	14.5	9	1.2	21.5	4	120
40067	41067	70.4	22	18.1	40	M6	79.2	15	14.5	9	1.2	21.5	4	120
40068	41068	70.4	22	18.1	50	M6	79.2	15	14.5	9	1.2	21.5	4	120
40069	41069	96	28.5	27.1	25	M8	108	24	18	11	1.5	33.3	8	350
40070	41070	96	28.5	27.1	30	M8	108	24	18	11	1.5	33.3	8	350
40071	41071	96	28.5	27.1	40	M8	108	24	18	11	1.5	33.3	8	350
40072	41072	96	28.5	27.1	50	M8	108	24	18	11	1.5	33.3	8	350
40073	41073	96	28.5	27.1	25	M8	108	24	18	11	1.5	33.3	8	350
40074	41074	96	28.5	27.1	30	M8	108	24	18	11	1.5	33.3	8	350
40075	41075	96	28.5	27.1	40	M8	108	24	18	11	1.5	33.3	8	350
40076	41076	96	28.5	27.1	50	M8	108	24	18	11	1.5	33.3	8	350



Cam Levers, Adjustable External Thread, Inch

- High quality industrial cam lever for clamping and quick change applications
- The threaded stud is free to rotate in the hinge pin. A screwdriver slot enables the user to adjust the tension of the stud and control the point at which the handle achieves optimal clamping. This is particularly useful in applications where obstructions permit clamping in less than a 360° circle.
- Available in inch or metric threads
- Cast aluminum handle, powder-coated in black
- Threaded components and washer in steel, trivalent blue passivated, or stainless steel
- Fiberglass reinforced plastic thrust washer

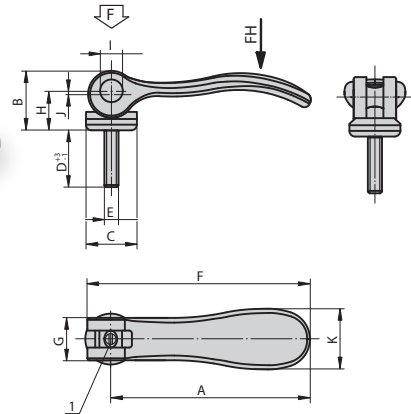

1. Screwdriver slot for fine adjustment of cam lever.

INCH		A	B	C	D	E	F	G	H	I	STROKE J	K	CLAMPING FORCE (lb-ft)	HAND FORCE lbf
STEEL	S.S.													
40115	41210	1.43	0.51	0.47	0.39	6-32	1.64	0.45	0.35	0.24	0.04	0.57	337	20
40116	41211	1.43	0.51	0.47	0.59	6-32	1.64	0.45	0.35	0.24	0.04	0.57	337	20
40117	41212	1.43	0.51	0.47	1.18	6-32	1.64	0.45	0.35	0.24	0.04	0.57	337	20
40118	41213	1.43	0.51	0.47	0.39	8-32	1.64	0.45	0.35	0.24	0.04	0.57	337	20
40119	41214	1.43	0.51	0.47	0.59	8-32	1.64	0.45	0.35	0.24	0.04	0.57	337	20
40120	41215	1.43	0.51	0.47	1.18	8-32	1.64	0.45	0.35	0.24	0.04	0.57	337	20
40121	41216	2.06	0.67	0.61	0.59	8-32	2.33	0.51	0.44	0.32	0.04	0.71	562	22
40122	41217	2.06	0.67	0.61	0.79	8-32	2.33	0.51	0.44	0.32	0.04	0.71	562	22
40123	41218	2.06	0.67	0.61	1.18	8-32	2.33	0.51	0.44	0.32	0.04	0.71	562	22
40124	41219	2.06	0.67	0.61	0.79	10-24	2.33	0.51	0.44	0.32	0.04	0.71	562	22
40125	41220	2.06	0.67	0.61	1.18	10-24	2.33	0.51	0.44	0.32	0.04	0.71	562	22
40126	41221	2.06	0.67	0.61	1.57	10-24	2.33	0.51	0.44	0.32	0.04	0.71	562	22
40127	41222	2.06	0.67	0.61	1.97	10-24	2.33	0.51	0.44	0.32	0.04	0.71	562	22
40128	41223	2.06	0.67	0.61	0.79	10-32	2.33	0.51	0.44	0.32	0.04	0.71	562	22
40129	41224	2.06	0.67	0.61	1.18	10-32	2.33	0.51	0.44	0.32	0.04	0.71	562	22
40130	41225	2.06	0.67	0.61	1.57	10-32	2.33	0.51	0.44	0.32	0.04	0.71	562	22
40131	41226	2.06	0.67	0.61	1.97	10-32	2.33	0.51	0.44	0.32	0.04	0.71	562	22
40132	41227	2.77	0.87	0.71	0.79	10-32	3.12	0.59	0.57	0.35	0.05	0.85	899	27
40133	41228	2.77	0.87	0.71	1.18	10-32	3.12	0.59	0.57	0.35	0.05	0.85	899	27
40134	41229	2.77	0.87	0.71	1.57	10-32	3.12	0.59	0.57	0.35	0.05	0.85	899	27
40135	41230	2.77	0.87	0.71	1.97	10-32	3.12	0.59	0.57	0.35	0.05	0.85	899	27
40136	41231	2.77	0.87	0.71	0.79	1/4/20	3.12	0.59	0.57	0.35	0.05	0.85	899	27
40137	41232	2.77	0.87	0.71	1.18	1/4/20	3.12	0.59	0.57	0.35	0.05	0.85	899	27
40138	41233	2.77	0.87	0.71	1.57	1/4/20	3.12	0.59	0.57	0.35	0.05	0.85	899	27
40139	41234	2.77	0.87	0.71	1.97	1/4/20	3.12	0.59	0.57	0.35	0.05	0.85	899	27
40140	41235	3.78	1.12	1.07	0.98	5/16-18	4.25	0.94	0.71	0.43	0.06	1.31	1798	79
40141	41236	3.78	1.12	1.07	1.18	5/16-18	4.25	0.94	0.71	0.43	0.06	1.31	1798	79
40142	41237	3.78	1.12	1.07	1.57	5/16-18	4.25	0.94	0.71	0.43	0.06	1.31	1798	79
40143	41238	3.78	1.12	1.07	1.97	5/16-18	4.25	0.94	0.71	0.43	0.06	1.31	1798	79
40144	41239	3.78	1.12	1.07	0.98	3/8-16	4.25	0.94	0.71	0.43	0.06	1.31	1798	79
40145	41240	3.78	1.12	1.07	1.18	3/8-16	4.25	0.94	0.71	0.43	0.06	1.31	1798	79
40146	41241	3.78	1.12	1.07	1.57	3/8-16	4.25	0.94	0.71	0.43	0.06	1.31	1798	79
40147	41242	3.78	1.12	1.07	1.97	3/8-16	4.25	0.94	0.71	0.43	0.06	1.31	1798	79



Cam Levers, Stainless Steel External Thread, Inch

- High quality industrial cam lever for clamping and quick change applications
- The adjustable cam lever with a stainless steel handle. The threaded stud is free to rotate in the hinge pin, which is pinged. A screwdriver slot enables the user to adjust the tension of the stud and control the point at which the handle achieves optimal clamping. This is particularly useful in applications where obstructions permit clamping in less than a 360° circle.
- Available in inch or metric threads
- Fiberglass reinforced plastic thrust washer

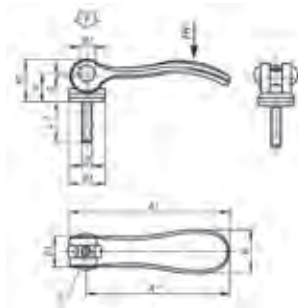

INCH	A	B	C	D	E	F	G	H	I	STROKE J	K	CLAMP-ING FORCE (lb-ft)	HAND FORCE lbf
41272	2.77	0.87	0.71	0.79	10-32	3.12	0.59	0.57	0.35	0.05	0.85	2950	26
41273	2.77	0.87	0.71	1.18	10-32	3.12	0.59	0.57	0.35	0.05	0.85	2950	26
41274	2.77	0.87	0.71	1.57	10-32	3.12	0.59	0.57	0.35	0.05	0.85	2950	26
41275	2.77	0.87	0.71	1.97	10-32	3.12	0.59	0.57	0.35	0.05	0.85	2950	26
41276	2.77	0.87	0.71	0.79	1/4-20	3.12	0.59	0.57	0.35	0.05	0.85	2950	26
41277	2.77	0.87	0.71	1.18	1/4-20	3.12	0.59	0.57	0.35	0.05	0.85	2950	26
41278	2.77	0.87	0.71	1.57	1/4-20	3.12	0.59	0.57	0.35	0.05	0.85	2950	26
41279	2.77	0.87	0.71	1.97	1/4-20	3.12	0.59	0.57	0.35	0.05	0.85	2950	26
41280	3.78	1.12	1.07	0.98	5/16-18	4.25	0.94	0.71	0.43	0.06	1.31	5900	78
41281	3.78	1.12	1.07	1.18	5/16-18	4.25	0.94	0.71	0.43	0.06	1.31	5900	78
41282	3.78	1.12	1.07	1.57	5/16-18	4.25	0.94	0.71	0.43	0.06	1.31	5900	78
41283	3.78	1.12	1.07	1.97	5/16-18	4.25	0.94	0.71	0.43	0.06	1.31	5900	78
41284	3.78	1.12	1.07	0.98	3/8-16	4.25	0.94	0.71	0.43	0.06	1.31	5900	78
41285	3.78	1.12	1.07	1.18	3/8-16	4.25	0.94	0.71	0.43	0.06	1.31	5900	78
41286	3.78	1.12	1.07	1.57	3/8-16	4.25	0.94	0.71	0.43	0.06	1.31	5900	78
41287	3.78	1.12	1.07	1.97	3/8-16	4.25	0.94	0.71	0.43	0.06	1.31	5900	78

Cam Levers, Stainless Steel External Thread, Metric

METRIC	A	B	C	D	E	F	G	H	I	STROKE J	K	CLAMP-ING FORCE (kN)	HAND FORCE N
41288	70.4	22	18.1	20	M5	79.2	15	14.5	9	1.2	21.5	4	120
41289	70.4	22	18.1	30	M5	79.2	15	14.5	9	1.2	21.5	4	120
41290	70.4	22	18.1	40	M5	79.2	15	14.5	9	1.2	21.5	4	120
41291	70.4	22	18.1	50	M5	79.2	15	14.5	9	1.2	21.5	4	120
41292	70.4	22	18.1	20	M6	79.2	15	14.5	9	1.2	21.5	4	120
41293	70.4	22	18.1	30	M6	79.2	15	14.5	9	1.2	21.5	4	120
41294	70.4	22	18.1	40	M6	79.2	15	14.5	9	1.2	21.5	4	120
41295	70.4	22	18.1	50	M6	79.2	15	14.5	9	1.2	21.5	4	120
41296	96	28.5	27.1	25	M8	108	24	18	11	1.5	33.3	8	350
41297	96	28.5	27.1	30	M8	108	24	18	11	1.5	33.3	8	350
41298	96	28.5	27.1	40	M8	108	24	18	11	1.5	33.3	8	350
41299	96	28.5	27.1	50	M8	108	24	18	11	1.5	33.3	8	350
41300	96	28.5	27.1	25	M10	108	24	18	11	1.5	33.3	8	350
41313	96	28.5	27.1	30	M10	108	24	18	11	1.5	33.3	8	350
41314	96	28.5	27.1	40	M10	108	24	18	11	1.5	33.3	8	350
41315	96	28.5	27.1	50	M10	108	24	18	11	1.5	33.3	8	350



Cam Levers, Stainless Steel *Internal Thread, Inch*

- High quality industrial cam lever for clamping and quick change applications
- Is a standard cam lever with a stainless steel handle and stainless steel components. The external thread version features a threaded stud pinged to the hinge pin for tool-less clamping. The internal thread version features a threaded hinge pin for attachment to an existing threaded stud.
- Available in inch or metric threads
- Fiberglass reinforced plastic thrust washer

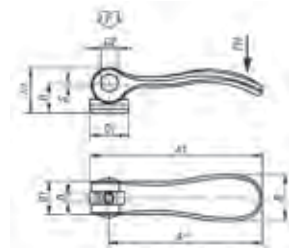

INCH	A	B	C	E	F	G	H	I	STROKE J	K	CLAMPING FORCE (lb-ft)	HAND FORCE lbf
41316	2.77	0.87	0.71	10-32	3.12	0.59	0.57	0.35	0.05	0.85	2950	26
41317	2.77	0.87	0.71	1/4-20	3.12	0.59	0.57	0.35	0.05	0.85	2950	26
41318	3.78	1.12	1.07	5/16-18	4.25	0.94	0.71	0.43	0.06	1.31	5900	78

Cam Levers, Stainless Steel *Internal Thread, Metric*

METRIC	A	B	C	E	F	G	H	I	STROKE J	K	CLAMPING FORCE (kN)	HAND FORCE N
41319	70.4	22	18.1	M5	79.2	15	14.5	9	1.2	21.5	4	120
41320	70.4	22	18.1	M6	79.2	15	14.5	9	1.2	21.5	4	120
41321	96	28.5	27.1	M8	108	24	18	11	1.5	33.3	8	350



Cam Levers, Plastic External Thread, Inch

- High quality industrial cam lever for clamping and quick change applications
- Is the standard cam lever with a plastic handle. The external thread version features a threaded stud pinged to the hinge pin for tool-less clamping. The internal thread version features a threaded hinge pin for attachment to an existing threaded stud.
- Available in inch or metric threads
- Fiberglass reinforced plastic handle
- Threaded components and washer in steel, trivalent blue passivated, or stainless steel
- Fiberglass reinforced plastic thrust washer

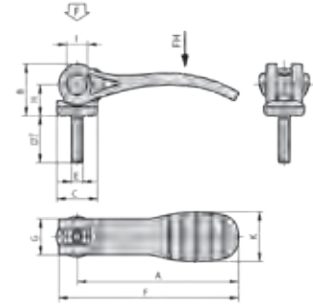

INCH		A	B	C	D	E	F	G	H	I	K	STROKE	CLAMPING FORCE (lb-ft)	HAND FORCE lbf
STEEL	S.S.													
40212	41119	2.81	0.92	0.71	0.79	10-32	3.13	0.63	0.55	0.35	0.87	0.05	562	28
40213	41120	2.81	0.92	0.71	1.18	10-32	3.13	0.63	0.55	0.35	0.87	0.05	562	28
40214	41121	2.81	0.92	0.71	1.57	10-32	3.13	0.63	0.55	0.35	0.87	0.05	562	28
40215	41122	2.81	0.92	0.71	1.97	10-32	3.13	0.63	0.55	0.35	0.87	0.05	562	28
40216	41123	2.81	0.92	0.71	0.79	1/4/20	3.13	0.63	0.55	0.35	0.87	0.05	562	28
40217	41124	2.81	0.92	0.71	1.18	1/4/20	3.13	0.63	0.55	0.35	0.87	0.05	562	28
40218	41125	2.81	0.92	0.71	1.57	1/4/20	3.13	0.63	0.55	0.35	0.87	0.05	562	28
40219	41126	2.81	0.92	0.71	1.97	1/4/20	3.13	0.63	0.55	0.35	0.87	0.05	562	28
40220	41127	3.94	1.09	1.07	0.98	5/16-18	4.33	0.95	0.64	0.43	1.30	0.06	1124	38
40221	41128	3.94	1.09	1.07	1.18	5/16-18	4.33	0.95	0.64	0.43	1.30	0.06	1124	38
40222	41129	3.94	1.09	1.07	1.57	5/16-18	4.33	0.95	0.64	0.43	1.30	0.06	1124	38
40223	41130	3.94	1.09	1.07	1.97	5/16-18	4.33	0.95	0.64	0.43	1.30	0.06	1124	38
40224	41131	3.94	1.09	1.07	0.98	3/8-16	4.33	0.95	0.64	0.43	1.30	0.06	1124	38
40225	41132	3.94	1.09	1.07	1.18	3/8-16	4.33	0.95	0.64	0.43	1.30	0.06	1124	38
40226	41133	3.94	1.09	1.07	1.57	3/8-16	4.33	0.95	0.64	0.43	1.30	0.06	1124	38
40227	41134	3.94	1.09	1.07	1.97	3/8-16	4.33	0.95	0.64	0.43	1.30	0.06	1124	38

Cam Levers, Plastic External Thread, Metric

METRIC		A	B	C	D	E	F	G	H	I	K	STROKE	CLAMPING FORCE (kN)	HAND FORCE N
STEEL	S.S.													
40228	41135	71.5	23.4	18.1	20	M5	79.6	16	14	9	22	1.15	2.5	125
40229	41136	71.5	23.4	18.1	30	M5	79.6	16	14	9	22	1.15	2.5	125
40230	41137	71.5	23.4	18.1	40	M5	79.6	16	14	9	22	1.15	2.5	125
40231	41138	71.5	23.4	18.1	50	M5	79.6	16	14	9	22	1.15	2.5	125
40232	41139	71.5	23.4	18.1	20	M6	79.6	16	14	9	22	1.15	2.5	125
40233	41140	71.5	23.4	18.1	30	M6	79.6	16	14	9	22	1.15	2.5	125
40234	41141	71.5	23.4	18.1	40	M6	79.6	16	14	9	22	1.15	2.5	125
40235	41142	71.5	23.4	18.1	50	M6	79.6	16	14	9	22	1.15	2.5	125
40236	41143	100	27.7	27.1	25	M8	110	24.2	16.2	11	33	1.5	5	170
40237	41144	100	27.7	27.1	30	M8	110	24.2	16.2	11	33	1.5	5	170
40238	41145	100	27.7	27.1	40	M8	110	24.2	16.2	11	33	1.5	5	170
40239	41146	100	27.7	27.1	50	M8	110	24.2	16.2	11	33	1.5	5	170
40240	41147	100	27.7	27.1	25	M10	110	24.2	16.2	11	33	1.5	5	170
40241	41148	100	27.7	27.1	30	M10	110	24.2	16.2	11	33	1.5	5	170
40242	41149	100	27.7	27.1	40	M10	110	24.2	16.2	11	33	1.5	5	170
40243	41150	100	27.7	27.1	50	M10	110	24.2	16.2	11	33	1.5	5	170

HANDLES, LEVERS & CRANKS



Cam Levers, Plastic Internal Thread, Inch

- High quality industrial cam lever for clamping and quick change applications
- Is the standard cam lever with a plastic handle. The external thread version features a threaded stud pinged to the hinge pin for tool-less clamping. The internal thread version features a threaded hinge pin for attachment to an existing threaded stud.
- Available in inch or metric threads
- Fiberglass reinforced plastic handle
- Threaded components and washer in steel, trivalent blue passivated, or stainless steel
- Fiberglass reinforced plastic thrust washer

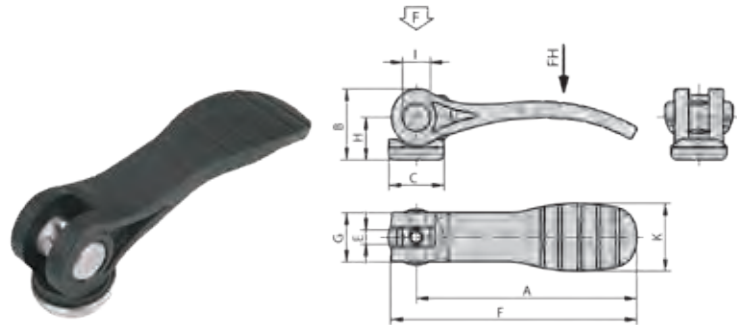

INCH		A	B	C	E	F	G	H	I	K	STROKE	CLAMPING FORCE F (lbf)	HAND FORCE lbf
STEEL	S.S.												
40206	41113	2.81	0.92	0.71	10-32	3.13	0.63	0.55	0.35	0.87	0.05	562	28
40207	41114	2.81	0.92	0.71	1/4-20	3.13	0.63	0.55	0.35	0.87	0.05	562	28
40208	41115	3.94	1.08	1.07	5/16-18	4.33	0.95	0.64	0.43	1.3	0.06	1124	28

Cam Levers, Plastic Internal Thread, Metric

METRIC		A	B	C	E	F	G	H	I	K	STROKE	CLAMPING FORCE F (kN)	HAND FORCE N
STEEL	S.S.												
40209	41116	71.5	23.4	18.1	M5	79.6	16	14	9	22	1.15	2.5	125
40210	41117	71.5	23.4	18.1	M6	79.6	16	14	9	22	1.15	2.5	125
40211	41118	100	27.7	27.1	M8	110	24.2	16.2	11	33	1.5	5	170



Cam Levers Adjustable, Stainless Steel External Thread, Inch

- High quality industrial cam lever for clamping and quick change applications
- Threaded stud is free to rotate in the hinge pin, unlike the standard version, which is pined. A screwdriver slot enables the user to adjust the tension of the stud and control the point at which the handle achieves optimal clamping. This is particularly useful in applications where obstructions permit clamping in less than a 360° circle.
- Available in inch or metric threads
- Fiberglass reinforced plastic thrust washer

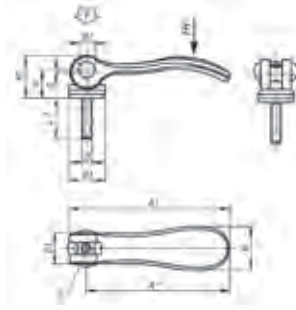

INCH	A	B	C	D	E	F	G	H	I	STROKE J	K	CLAMP-ING FORCE (lb-ft)	HAND FORCE lbf
41272	2.77	0.87	0.71	0.79	10-32	3.12	0.59	0.57	0.35	0.05	0.85	2950	26
41273	2.77	0.87	0.71	1.18	10-32	3.12	0.59	0.57	0.35	0.05	0.85	2950	26
41274	2.77	0.87	0.71	1.57	10-32	3.12	0.59	0.57	0.35	0.05	0.85	2950	26
41275	2.77	0.87	0.71	1.97	10-32	3.12	0.59	0.57	0.35	0.05	0.85	2950	26
41276	2.77	0.87	0.71	0.79	1/4-20	3.12	0.59	0.57	0.35	0.05	0.85	2950	26
41277	2.77	0.87	0.71	1.18	1/4-20	3.12	0.59	0.57	0.35	0.05	0.85	2950	26
41278	2.77	0.87	0.71	1.57	1/4-20	3.12	0.59	0.57	0.35	0.05	0.85	2950	26
41279	2.77	0.87	0.71	1.97	1/4-20	3.12	0.59	0.57	0.35	0.05	0.85	2950	26
41280	3.78	1.12	1.07	0.98	5/16-18	4.25	0.94	0.71	0.43	0.06	1.31	5900	78
41281	3.78	1.12	1.07	1.18	5/16-18	4.25	0.94	0.71	0.43	0.06	1.31	5900	78
41282	3.78	1.12	1.07	1.57	5/16-18	4.25	0.94	0.71	0.43	0.06	1.31	5900	78
41283	3.78	1.12	1.07	1.97	5/16-18	4.25	0.94	0.71	0.43	0.06	1.31	5900	78
41284	3.78	1.12	1.07	0.98	3/8-16	4.25	0.94	0.71	0.43	0.06	1.31	5900	78
41285	3.78	1.12	1.07	1.18	3/8-16	4.25	0.94	0.71	0.43	0.06	1.31	5900	78
41286	3.78	1.12	1.07	1.57	3/8-16	4.25	0.94	0.71	0.43	0.06	1.31	5900	78
41287	3.78	1.12	1.07	1.97	3/8-16	4.25	0.94	0.71	0.43	0.06	1.31	5900	78

Cam Levers Adjustable, Stainless Steel External Thread, Metric

METRIC	A	B	C	D	E	F	G	H	I	STROKE J	K	CLAMP-ING FORCE (kN)	HAND FORCE N
41288	70.4	22	18.1	20	M5	79.2	15	14.5	9	1.2	21.5	4	120
41289	70.4	22	18.1	30	M5	79.2	15	14.5	9	1.2	21.5	4	120
41290	70.4	22	18.1	40	M5	79.2	15	14.5	9	1.2	21.5	4	120
41291	70.4	22	18.1	50	M5	79.2	15	14.5	9	1.2	21.5	4	120
41292	70.4	22	18.1	20	M6	79.2	15	14.5	9	1.2	21.5	4	120
41293	70.4	22	18.1	30	M6	79.2	15	14.5	9	1.2	21.5	4	120
41294	70.4	22	18.1	40	M6	79.2	15	14.5	9	1.2	21.5	4	120
41295	70.4	22	18.1	50	M6	79.2	15	14.5	9	1.2	21.5	4	120
41296	96	28.5	27.1	25	M8	108	24	18	11	1.5	33.3	8	350
41297	96	28.5	27.1	30	M8	108	24	18	11	1.5	33.3	8	350
41298	96	28.5	27.1	40	M8	108	24	18	11	1.5	33.3	8	350
41299	96	28.5	27.1	50	M8	108	24	18	11	1.5	33.3	8	350
41300	96	28.5	27.1	25	M10	108	24	18	11	1.5	33.3	8	350
41313	96	28.5	27.1	30	M10	108	24	18	11	1.5	33.3	8	350
41314	96	28.5	27.1	40	M10	108	24	18	11	1.5	33.3	8	350
41315	96	28.5	27.1	50	M10	108	24	18	11	1.5	33.3	8	350



Cam Levers, Adjustable Plastic External Thread, Inch

- High quality industrial cam lever for clamping and quick change applications
- Adjustable cam lever with a fiberglass reinforced plastic handle. The threaded stud is free to rotate in the hinge pin. A screwdriver slot enables the user to adjust the tension of the stud and control the point at which the handle achieves optimal clamping. This is particularly useful in applications where obstructions permit clamping in less than a 360° circle.
- Available in inch or metric threads
- Fiberglass reinforced plastic handle
- Threaded components and washer in steel, trivalent blue passivated, or stainless steel
- Fiberglass reinforced plastic thrust washer

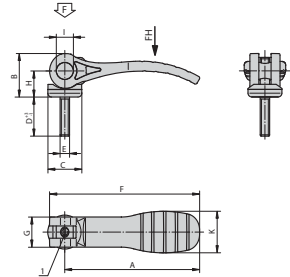

INCH		A	B	C	D	E	F	G	H	I	K	STROKE	CLAMPING FORCE F (lbf)	HAND FORCE lbf
STEEL	S.S.													
40244	41158	2.81	0.92	0.71	0.79	10-32	3.13	0.63	0.55	0.35	0.87	0.05	562	28
40245	41159	2.81	0.92	0.71	1.18	10-32	3.13	0.63	0.55	0.35	0.87	0.05	562	28
40246	41160	2.81	0.92	0.71	1.57	10-32	3.13	0.63	0.55	0.35	0.87	0.05	562	28
40247	41161	2.81	0.92	0.71	1.97	10-32	3.13	0.63	0.55	0.35	0.87	0.05	562	28
40248	41162	2.81	0.92	0.71	0.79	1/4-20	3.13	0.63	0.55	0.35	0.87	0.05	562	28
40249	41163	2.81	0.92	0.71	1.18	1/4-20	3.13	0.63	0.55	0.35	0.87	0.05	562	28
40250	41164	2.81	0.92	0.71	1.57	1/4-20	3.13	0.63	0.55	0.35	0.87	0.05	562	28
40251	41165	2.81	0.92	0.71	1.97	1/4-20	3.13	0.63	0.55	0.35	0.87	0.05	562	28
40252	41166	3.94	1.09	1.06	0.98	5/16-18	4.33	0.95	0.64	0.43	1.30	0.06	1124	38
40253	41167	3.94	1.09	1.06	1.18	5/16-18	4.33	0.95	0.64	0.43	1.30	0.06	1124	38
40254	41168	3.94	1.09	1.06	1.57	5/16-18	4.33	0.95	0.64	0.43	1.30	0.06	1124	38
40255	41169	3.94	1.09	1.06	1.97	5/16-18	4.33	0.95	0.64	0.43	1.30	0.06	1124	38
40256	41170	3.94	1.09	1.06	0.98	3/8-16	4.33	0.95	0.64	0.43	1.30	0.06	1124	38
40257	41171	3.94	1.09	1.06	1.18	3/8-16	4.33	0.95	0.64	0.43	1.30	0.06	1124	38
40258	41172	3.94	1.09	1.06	1.57	3/8-16	4.33	0.95	0.64	0.43	1.30	0.06	1124	38
40259	41173	3.94	1.09	1.06	1.97	3/8-16	4.33	0.95	0.64	0.43	1.30	0.06	1124	38

Cam Levers, Adjustable Plastic External Thread, Metric

METRIC		A	B	C	D	E	F	G	H	I	K	STROKE	CLAMPING FORCE F (kN)	HAND FORCE N
STEEL	S.S.													
40260	41174	71.5	23.4	18.1	20	M5	79.6	16	14	9	22	1.15	2.5	125
40261	41175	71.5	23.4	18.1	30	M5	79.6	16	14	9	22	1.15	2.5	125
40262	41176	71.5	23.4	18.1	40	M5	79.6	16	14	9	22	1.15	2.5	125
40263	41177	71.5	23.4	18.1	50	M5	79.6	16	14	9	22	1.15	2.5	125
40264	41178	71.5	23.4	18.1	20	M6	79.6	16	14	9	22	1.15	2.5	125
40265	41179	71.5	23.4	18.1	30	M6	79.6	16	14	9	22	1.15	2.5	125
40266	41180	71.5	23.4	18.1	40	M6	79.6	16	14	9	22	1.15	2.5	125
40267	41181	71.5	23.4	18.1	50	M6	79.6	16	14	9	22	1.15	2.5	125
40268	41182	100	27.7	27.1	25	M8	110	24	16.2	11	33	1.5	5	170
40269	41183	100	27.7	27.1	30	M8	110	24	16.2	11	33	1.5	5	170
40270	41184	100	27.7	27.1	40	M8	110	24	16.2	11	33	1.5	5	170
40271	41185	100	27.7	27.1	50	M8	110	24	16.2	11	33	1.5	5	170
40272	41186	100	27.7	27.1	25	M10	110	24	16.2	11	33	1.5	5	170
40273	41187	100	27.7	27.1	30	M10	110	24	16.2	11	33	1.5	5	170
40274	41188	100	27.7	27.1	40	M10	110	24	16.2	11	33	1.5	5	170
40275	41189	100	27.7	27.1	50	M10	110	24	16.2	11	33	1.5	5	170

HANDLES, LEVERS & CRANKS



Ergonomic Style Steel Handles

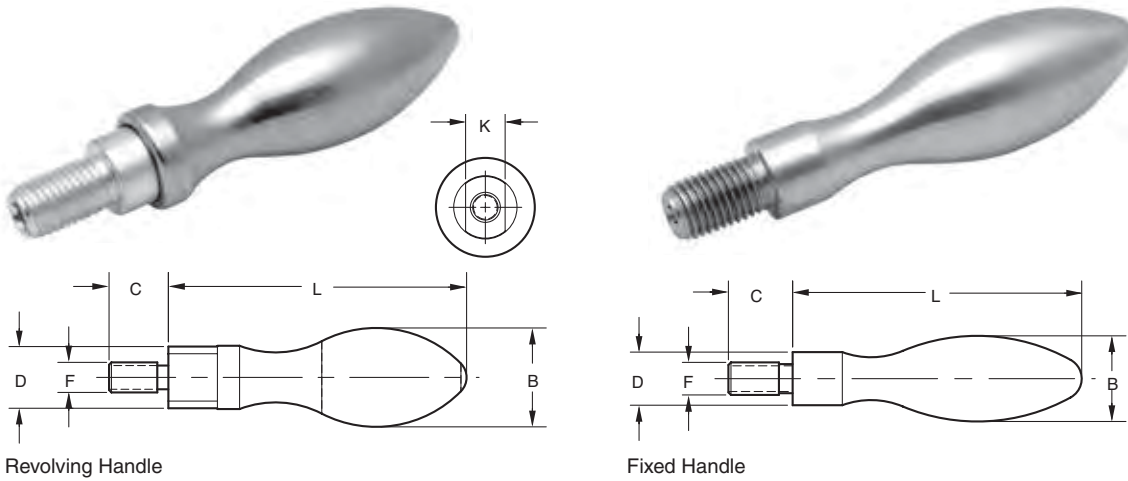

Revolving Handle

Fixed Handle

Part Number	Style	F (Thread)	B	C	D	L	K
22000	Revolving	10 - 24	1/2	3/8	0.32	1-7/8	1/4
22001	Revolving	1/4 - 20	5/8	1/2	0.40	2-1/4	5/16
22002	Revolving	5/16 - 18	13/16	9/16	0.51	2-13/16	3/8
22003	Revolving	3/8 - 16	1	11/16	0.63	3-3/8	7/16
22011	Fixed	10 - 24	1/2	3/8	0.32	1-11/16	—
22012	Fixed	1/4 - 20	5/8	1/2	0.40	2	—
22013	Fixed	5/16 - 18	13/16	9/16	0.51	2-5/8	—
22014	Fixed	3/8 - 16	1	11/16	0.63	3-3/16	—

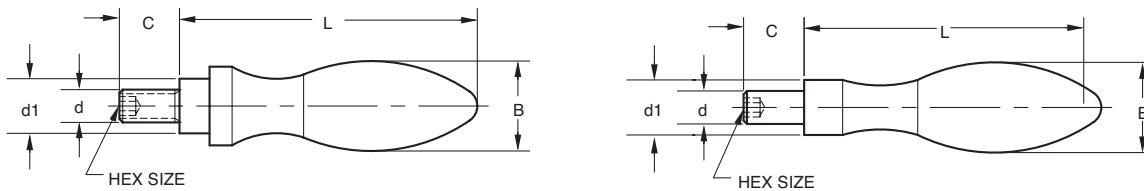

Metric Revolving Style

Metric Fixed Style

Metric

Part Number*	Style	d (Thread)	L	B	C	d1
22050	Revolving	M6	54.5	16	11	10
22051	Revolving	M8	67	20	13	13
22052	Revolving	M10	83	25	14	16
22053	Revolving	M12	105.5	32	21	20
22054	Revolving	M16	117	36	26	22
22055	Fixed	M6	54	16	11	10
22056	Fixed	M8	64	20	13	13
22057	Fixed	M10	80	25	14	16
22058	Fixed	M12	100	32	21	20
22059	Fixed	M16	112	36	26	22

*Dimensions in millimeters



Plastic Revolving Heavy Duty Handle With Steel Shank ELESA Original Design



- Material: Black Duroplast
- Finish: Black Bright
- Shank: Zinc Plated Steel or Stainless Steel 303
- Resistant to Solvents, Oils, Greases, and other Chemical Agents

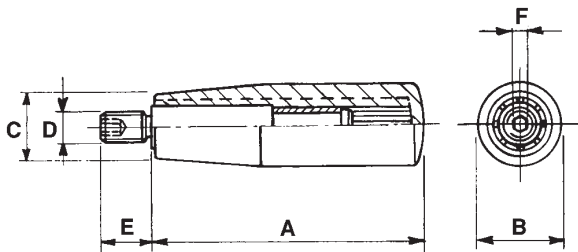

With Steel Shank

Part Number	A	B	C	D*	E	F
33621	1.57	.71	.59	M6	.51	.12
33622	1.97	.83	.67	M6	.51	.12
33624	2.56	.91	.75	M8	.59	.16
33625	3.15	1.02	.83	M10	.67	.20
33626	3.54	1.10	.87	M10	.67	.20

*Dimension in millimeters

With Stainless Steel Shank

Part Number	A	B	C	D*	E	F
34102	1.97	.83	.67	M6	.51	.12
34103	2.56	.91	.75	M8	.59	.16
34104	3.15	1.02	.83	M10	.67	.20
34105	3.54	1.10	.87	M10	.67	.20

*Dimension in millimeters

Plastic Revolving Handle With Steel Through Shank ELESA Original Design



- Material: Black Duroplast
- Finish: Black Bright
- Shank: Matte Chrome Plated Steel
- Resistant to Solvents, Oils, Greases, and other Chemical Agents

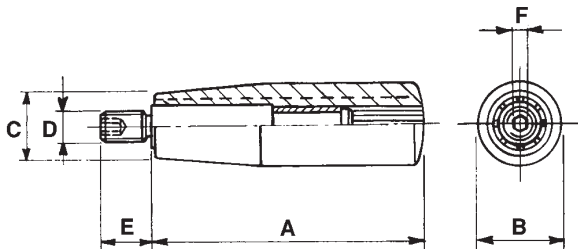

Part Number	A	B	C	D	E	F
33601	1.57	.71	.59	1/4-20	.51	5/32
33602	1.97	.83	.67	5/16-18	.59	3/16
33604	2.56	.91	.75	5/16-18	.67	1/4
33605	3.15	1.02	.83	3/8-16	.71	1/4
33606	3.54	1.10	.87	3/8-16	.71	5/16



Plastic Revolving Handle With Steel Shank ELESA Original Design



- Material: High Impact Strength Technopolymer
- Finish: Black Matte
- Shank: Zinc Plated Steel
- Resistant to Solvents, Oils, Greases, and other Chemical Agents

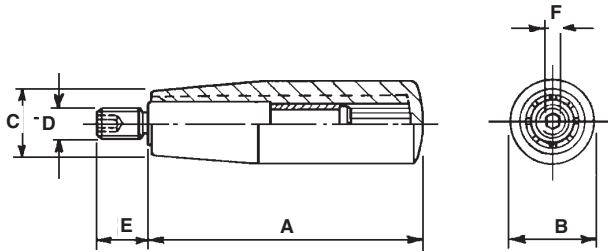

Part Number	A	B	C	D*	E	F
33611	1.57	.71	.59	M6	.51	.12
33612	1.97	.83	.67	M6	.51	.12
33613	2.20	.87	.71	M6	.51	.12
33614	2.56	.91	.75	M8	.59	.16
33615	3.15	1.02	.83	M8	.59	.16
33616	3.54	1.10	.87	M10	.67	.20

*Dimension in millimeters

Revolving Handle ELESA Original Design



- Material: High Impact Strength Technopolymer
- Finish: Gray/Black Matte
- Stud: Zinc Plated Steel
- Resistant to Solvents, Oils, Greases, and other Chemical Agents

Part Number	A	B	C	D	E*	F	G
34471	2.56	.81	.59	.73	M6	.51	.12
34472	2.87	.87	.63	.75	M8	.59	.16
34473	3.39	.96	.69	.94	M8	.59	.16
34474	3.39	.96	.69	.94	M10	.67	.20
34475	3.74	1.04	.71	.98	M10	.67	.20

*Dimension in millimeters

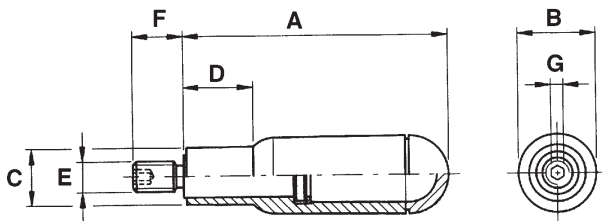



Plastic Heavy Duty Tapered Handle



- Use as grasp handles on portable tools or as machine shift levers
- Inserts: Brass
- 3D Solid Models are available in multiple formats from www.jergensinc.com

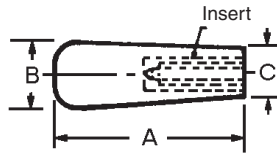

With Tapped Holes

Part Number	A	B	C	Insert Thread and Depth
32105	4 1/2	1 3/8	1	3/8-16 x 5/8
32106	4 1/2	1 3/8	1	3/8-24 x 5/8
32101	4 1/2	1 3/8	1	3/8-16 x 2
32107	4 1/2	1 3/8	1	1/2-13 x 5/8
32108	4 1/2	1 3/8	1	1/2-20 x 5/8
32103	4 1/2	1 3/8	1	1/2-13 x 1 1/4
32104	4 1/2	1 3/8	1	5/8-18 x 3/4

Plastic Light Duty Tapered Handle



- Use as grasp handles on small tools, utensils, and gauges
- Inserts: Brass
- Through hole style for use with a socket head cap screw
- 3D Solid Models are available in multiple formats from www.jergensinc.com

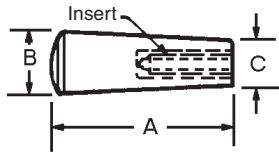

With Tapped Holes

Part Number	A	B	C	Insert Thread and Depth
32111	2 5/8	1	5/8	1/4-20 x 7/16
32112	2 5/8	1	5/8	5/16-18 x 7/16
32117	2 5/8	1	5/8	3/8-16 x 1/2
32118	3 7/8	1 1/8	3/4	1/4-20 x 1/2
32119	3 7/8	1 1/8	3/4	5/16-18 x 7/16
32109	3 7/8	1 1/8	3/4	3/8-16 x 5/8
32102	3 7/8	1 1/8	3/4	3/8-16 x 2
32110*	3 7/8	1 1/8	3/4	.500/.510 x 2

* Cored Hole

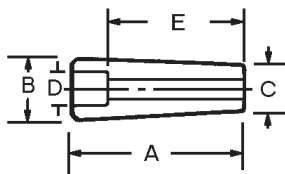

With Through Hole

Part Number	A	B	C	D	E	Through Hole Size
32113	2 9/16	1	5/8	1/2	5/8	.251/.256
32114	3 11/16	1 1/8	3/4	3/4	2 5/8	.380/.385



Fold-Away Handle ELESA Original Design



- Material: High Impact Strength Technopolymer
- Finish: Gray/Black Matte
- Base: Sintered and Oxidized
- Resistant to Solvents, Oils, Greases, and other Chemical Agents

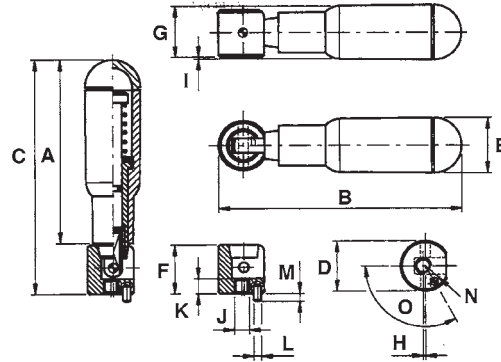

Part Number	A	B	C	D	E	F	G	H	I	J	K	L	M	N	O
34481	2.56	3.27	3.17	.63	.81	.59	.75	.04	.06	M4	.20	.12	.12	.22	90°
34482	2.87	3.58	3.48	.63	.87	.59	.77	.04	.10	M4	.20	.12	.12	.22	90°
34483	2.87	3.82	3.66	.79	.87	.77	.85	.02	.02	M6	.24	.12	.12	.22	120°
34484	3.39	4.33	4.17	.79	.96	.77	.91	.02	.06	M6	.24	.12	.12	.28	120°
34485	3.74	4.69	4.53	.79	1.04	.77	.94	.02	.10	M6	.24	.12	.12	.28	120°

Plastic Revolving Fold-Away Handle ELESA Original Design



- Material: High Impact Strength Technopolymer
- Finish: Black Matte
- Stud: Black Oxide Steel Double Guide
- Resistant to Solvents, Oils, Greases, and other Chemical Agents

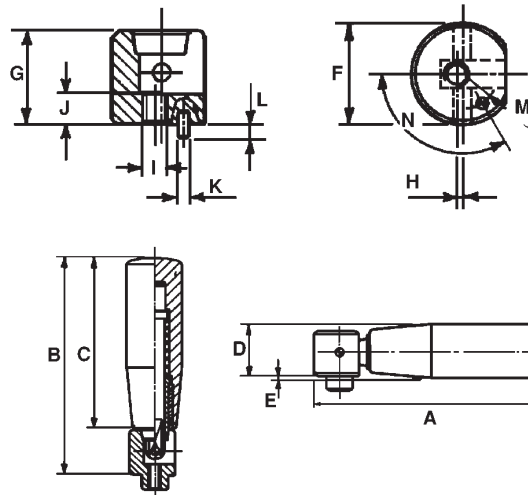

Part Number	A	B	C	D	E	F	G	H	I	J	K	L	M	N
33631	2.91	2.80	2.20	.75	.10	.63	.59	.04	M4	.20	.12	.12	.22	90°
33632	3.27	3.15	2.56	.79	.12	.63	.59	.04	M4	.20	.12	.12	.22	90°
33633	3.50	3.35	2.56	.87	.04	.79	.77	.02	M6	.24	.12	.12	.28	120°
33634	4.09	3.94	3.15	.94	.10	.79	.77	.02	M6	.24	.12	.12	.28	120°
33635	4.49	4.33	3.54	.94	.12	.79	.77	.02	M6	.24	.12	.12	.28	120°
33636	4.65	4.45	3.54	1.06	.04	1.02	.91	.06	M6	.28	.12	.12	.37	90°



Plastic Crank With Revolving Handle ELESA Original Design

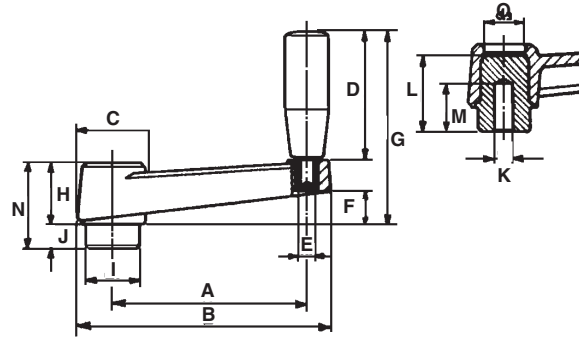

- Material: Glass-Fibre Reinforced Technopolymer
- Finish: Black Matte
- Ribbed Structure for heavy duty applications
- Hub: Black Oxide Steel
- Resistant to Solvents, Oils, Greases, and other Chemical Agents
- Available in Ergostyle®. See Ergostyle Section.
- 3D Solid Models are available in multiple formats from www.jergensinc.com

Part Number	A	B	C	D	E*	F	G	H	I	J	K	L	M	N	O
33651	2.52	3.39	1.06	1.57	M6	.39	2.48	.91	.71	.39	.236	1.14	.71	1.30	.63
33652	3.15	4.13	1.18	1.97	M6	.51	2.99	1.02	.87	.39	.236	1.26	1.02	1.42	.67
33653	3.94	5.04	1.34	2.56	M8	.59	3.78	1.18	.94	.39	.315	1.46	1.10	1.57	.83
33654	5.11	6.37	1.57	3.15	M8	.79	4.52	1.37	1.10	.55	.394	1.73	1.18	1.93	.98
33655	6.30	7.80	1.77	3.54	M10	.91	5.12	1.57	1.34	.59	.394	1.93	1.18	2.17	1.06
33656	8.35	8.92	1.97	3.54	M10	1.02	5.35	1.77	1.57	.59	.472	2.09	1.18	2.36	1.22

*Dimension in millimeters

Plastic Crank With Revolving Fold-Away Handle ELESA Original Design

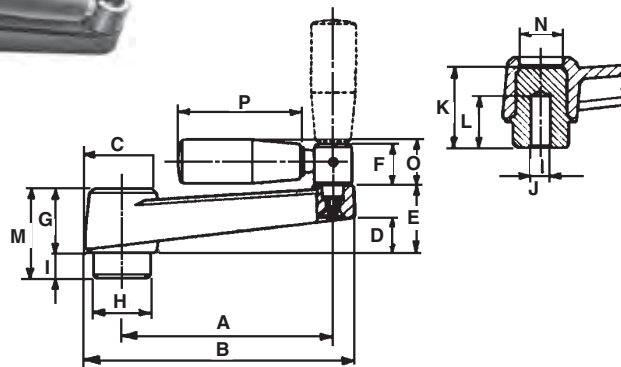

- Material: Glass-Fibre Reinforced Technopolymer
- Finish: Black Matte
- Ribbed Structure for heavy duty applications
- Hub: Black Oxide Steel
- Resistant to Solvents, Oils, Greases, and other Chemical Agents
- 3D Solid Models are available in multiple formats from www.jergensinc.com

Part Number	A	B	C	D	E	F	G	H	I	J	K	L	M	N	O	P
33662	3.15	4.13	1.18	.51	1.06	.59	1.02	.87	.39	.236	1.26	1.02	1.42	.67	.74	2.20
33663	3.94	5.04	1.34	.59	1.22	.79	1.18	.94	.39	.315	1.46	1.10	1.57	.83	.86	2.56
33664	5.11	6.37	1.57	.78	1.37	.79	1.37	1.10	.55	.394	1.73	1.18	1.93	.98	.86	2.56
33665	6.30	7.80	1.77	.91	1.57	.79	1.57	1.34	.59	.394	1.93	1.18	2.17	1.06	.94	3.15
33666	8.35	8.92	1.97	1.02	1.81	.91	1.77	1.57	.59	.472	2.09	1.18	2.36	1.22	1.06	3.54



Aluminum & Malleable Speed Handle

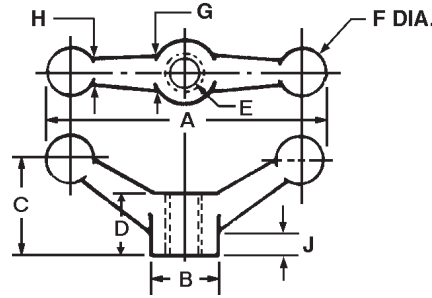

- Material: 319 Aluminum
Malleable ASTM A47, GR32510
- Finish: Mill
- Thread: 2B-UNC or class 6h
- Can be used with rod ends for clamping tank covers, locking lids or any fast spin locking application
- With or without tapped or blank hole
- Three head widths
- 3D Solid Models are available in multiple formats from www.jergensinc.com
- "D" dimension is based on machined castings. It may be slightly greater on blanks.

Part Number		A	B	C	D	E	Dia F	G	H	J
Aluminum	Malleable									
39901	40301	4 1/2	1 1/8	1 1/2	1	Blank	11/16	3/4	7/16	1/2
39902	40302	4 1/2	1 1/8	1 1/2	1	3/8-16	11/16	3/4	7/16	1/2
39903	40303	4 1/2	1 1/8	1 1/2	1	1/2-13	11/16	3/4	7/16	1/2
39904	40304	6	1 1/2	2 1/8	1 1/2	Blank	.94	7/8	5/8	3/4
39905	40305	6	1 1/2	2 1/8	1 1/2	1/2-13	.94	7/8	5/8	3/4
39906	40306	6	1 1/2	2 1/8	1 1/2	5/8-11	.94	7/8	5/8	3/4
39907	40307	8 3/4	2	3	2	Blank	1 3/16	1.02	7/8	.94
—	40308	8 3/4	2	3	2	3/4-10	1 3/16	1.02	7/8	.94

Part Number		A	B	C	D	E*	Dia F	G	H	J
Aluminum	Malleable									
39901	40301	113	28	38	25	Blank	17	19	11	13
39952	40352	113	28	38	25	M10	17	19	11	13
39953	40353	113	28	38	25	M12	17	19	11	13
39904	40304	150	38	53	38	Blank	24	22	16	19
39955	40355	150	38	53	38	M12	24	22	16	19
39956	40356	150	38	53	38	M16	24	22	16	19
39907	40307	219	50	75	50	Blank	30	26	22	24
—	40358	222	50	75	50	M20	30	26	22	24

*Dimension in millimeters



Steel Solid and Revolving Balanced Crank Handle

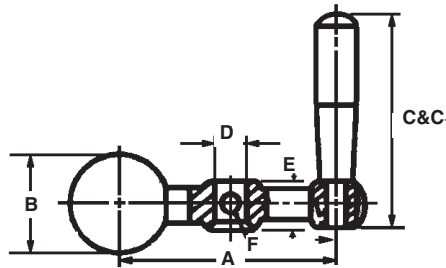

SOLID HANDLE DOES NOT REVOLVE

- Material: Steel
- Finish: Bright Chrome
- 3D Solid Models are available in multiple formats from www.jergensinc.com
- Revolving Handle is a replacement set for Bridgeport Style Mills

Part Number		A	B	C	C [†]	Reamed D	E	Center Hole* F
Solid	Revolving							
11401	—	2	13/16	2	—	5/16	7/16	1/8
11402	11412	2 1/2	1	2 1/2	2 3/4	5/16	9/16	1/8
11403	11413	3 1/8	1 1/4	3 1/4	3 1/2	3/8	11/16	5/32
11404	11414	4	1 1/4	3 1/4	3 1/2	3/8	11/16	5/32
11405	11415	5	1 1/2	4	4 3/16	1/2	7/8	3/16
11406	—	6 1/8	1 1/2	4	—	1/2	7/8	3/16

* Center Hole is cross drilled on one side.

† Dimension for Revolving Style

Aluminum Balanced Crank Handle

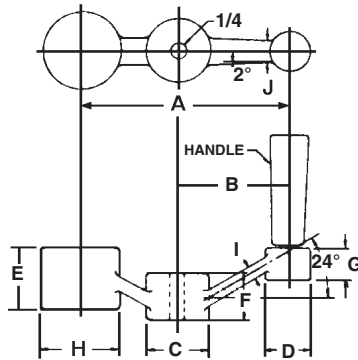

Jergens Aluminum Balanced Crank Handles are good replacements for heavier steel handles. The light-weight characteristics make table positioning easier as no fall-off occurs after position has been established. Light-weight Aluminum Balanced Crank Handles are ideal for applications such as optical jig boring equipment and inspection instruments.

- Material: 319 Aluminum Alloy
- Finish: Grey Enamel
- 3D Solid Models are available in multiple formats from www.jergensinc.com

Part Number	A	B	C	D	E	F	G	H	I	J	Handle	Wt. (lbs)
11301	2 5/16	1 1/4	3/4	1/2	11/16	1/2	7/16	7/8	3/16	5/16	21902	.14
11302	3 1/16	1 11/16	1	5/8	7/8	5/8	1/2	1 1/4	1/4	3/8	21903	.30
11303	3 15/16	2 1/8	1 1/8	3/4	1 3/16	3/4	5/8	1 3/8	5/16	7/16	21904	.54
11304	4 11/16	2 9/16	1 3/8	7/8	1 5/16	1	3/4	1 5/8	5/16	1/2	21905	.75
11305	5 11/16	3 1/16	1 3/8	7/8	1 1/2	1	1	1 3/4	3/8	9/16	21905	.90



Forged Crank Handle

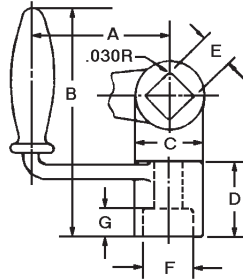

- Material: C-1021 Forging
- Finish: Mill
- 3D Solid Models are available in multiple formats from www.jergensinc.com

Blank Crank Handles

Part Number	A	B	C	D	Wt. (lbs)
20501	2 1/2	3 3/4	1	1/4	.60
20503	3	4 1/4	1 1/4	1 1/2	.97
20504	3 1/2	4 3/16	1 1/16	1 5/16	.90
20505	4	4 1/2	1 1/4	1 3/8	1.14
20506	5	4 15/16	1 1/4	1 13/16	1.62
20507	6	5 1/16	1 1/4	1 15/16	1.62
20508	7	5 7/16	1 3/8	2 1/16	1.95
20509	8	6 1/16	1 9/16	2 7/16	3.00
20510	9 1/8	6 1/4	1 1/2	2 1/2	3.25
20511	10	7	1 3/4	3	4.37

Finished Crank Handles

Part Number	E	F	G	Wt. (lbs)
20301	1/2 Sq.	3/4	3/16	.50
20303	9/16 Sq.	3/4	1/4	.82
20304	1/2 Sq.	11/16	1/4	.74
20305	9/16 Sq.	3/4	5/16	.97
20306	5/8 Sq.	7/8	3/8	1.37
20307	11/16 Sq.	15/16	3/8	1.25
20308	3/4 Sq.	1 1/16	1/2	1.67
20309	7/8 Sq.	1 1/4	1/2	2.44
20310	7/8 Sq.	1 1/4	1/2	2.60
20311	1 Sq.	1 3/8	9/16	3.62

Steel Clamp Lever



- Material: Lever, Low Carbon Steel
Ball, Plastic
- Finish: Lever, Satin Chrome Plate
Ball, Black

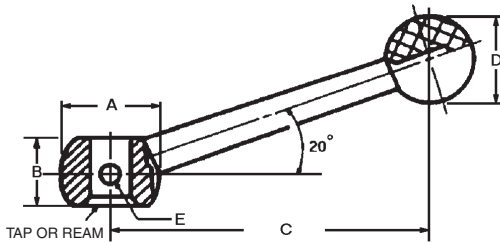

Part Number	Hub Style	A	B	C	D	E
16601	1/4 Ream	5/8	7/16	2 1/4	3/4	1/8
16602	5/16-18 Tap	5/8	7/16	2 1/4	3/4	—
16603	5/16 Ream	25/32	9/16	2 3/4	13/16	1/8
16604	3/8-16 Tap	25/32	9/16	2 3/4	13/16	—
16605	3/8 Ream	1	3/4	3 1/2	15/16	5/32
16606	1/2-13 Tap	1	3/4	3 1/2	15/16	—
16607	1/2 Ream	1 1/4	7/8	4 3/8	1 1/4	3/16
16608	5/8-11 Tap	1 1/4	7/8	4 3/8	1 1/4	—
16609	5/8 Ream	1 9/16	1 1/8	5 1/2	1 1/2	1/4
16610	3/4-10 Tap	1 9/16	1 1/8	5 1/2	1 1/2	—

HANDLES, LEVERS & CRANKS



Single Handle Locking Lever



A fast and efficient means of clamping and locking on jigs, fixtures, machine tools and special applications where high clamping force is necessary.

- Material: Low Carbon Steel
- Finish: Zinc Plate
- Thread: Class 2B-UNC
- Handles: Copper Brazed into the hubs
- Ream: + .001
- .000
- 3D Solid Models are available in multiple formats from www.jergensinc.com

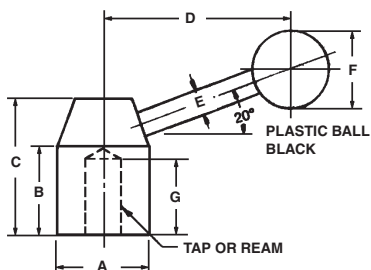

Part Number	A	B	C	D	E	F	G	Hub Style
28901	1	1	1 1/2	2	1/4	1	—	Blank
28902	1	1	1 1/2	2	1/4	1	11/16	3/8-16 Tap
28903	1	1	1 1/2	2	1/4	1	13/16	3/8 Ream
28904	1 1/4	1 1/8	1 11/16	3	3/8	1	—	Blank
28905	1 1/4	1 1/8	1 11/16	3	3/8	1	3/4	1/2-13 Tap
28906	1 1/4	1 1/8	1 11/16	3	3/8	1	7/8	1/2 Ream
28907	1 1/2	1 1/4	2	4	1/2	1 3/8	—	Blank
28908	1 1/2	1 1/4	2	4	1/2	1 3/8	15/16	5/8-11 Tap
28909	1 1/2	1 1/4	2	4	1/2	1 3/8	1 1/16	5/8 Ream

Metric

Part Number*	A	B	C	D	E	F	G	Hub Style
28901	25	25	38	50	6	25	-	Blank
28952	25	25	38	50	6	25	17	M8 Tap
28953	25	25	38	50	6	25	20	8mm Ream
28904	31	28	42	75	9	25	-	Blank
28955	31	28	42	75	9	25	19	M12 Tap
28956	31	28	42	75	9	25	22	12mm Ream
28907	38	31	50	100	13	34	-	Blank
28958	38	31	50	100	13	34	23	M16 Tap
28959	38	31	50	100	13	34	27	16mm Ream

*Dimensions in millimeters

Aluminum & Malleable Offset Handle



- Material: 319 Aluminum Alloy
Malleable ASTM A47, GR32510
- Finish: Mill
- 3D Solid Models are available in multiple formats from www.jergensinc.com

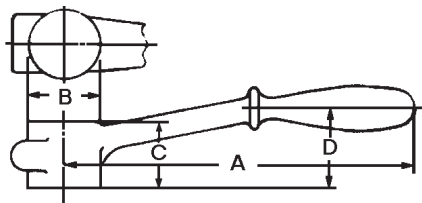

Aluminum

Part Number	A	B	C	D	Wt. (lbs)
29901	4 1/2	1	3/4	1	.15
29902	6	1 1/2	1 1/4	1 3/4	.44
29903	11	1 5/8	1 3/8	1 15/16	.78

Malleable

Part Number	Wt. (lbs)
30101	.45
30102	1.24
30103	2.25



Double Handle Locking Lever

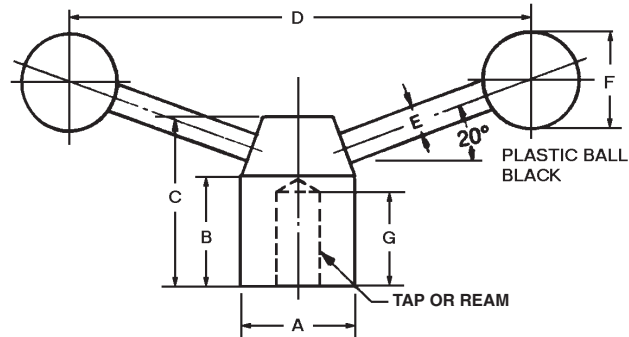

- Material: Low Carbon Steel
- Finish: Zinc Plate
- Thread: Class 2B-UNC or Class 6h
- Handles: Copper brazed into the hubs
- Ream: + .001
- .000
- Metric Ream:
+ .025
- .000
- 3D Solid Models are available in multiple formats from www.jergensinc.com

Part Number	A	B	C	D	E	F	G	Hub Style
28910	1	1	1 1/2	4	1/4	1	—	Blank
28911	1	1	1 1/2	4	1/4	1	11/16	3/8-16 Tap
28912	1 1/4	1 1/8	1 11/16	6	3/8	1	—	Blank
28913	1 1/4	1 1/8	1 11/16	6	3/8	1	3/4	1/2-13 Tap
28914	1 1/2	1 1/4	2	8	1/2	1 3/8	—	Blank
28915	1 1/2	1 1/4	2	8	1/2	1 3/8	15/16	5/8-11 Tap
28916	1 1/2	1 1/4	2	8	1/2	1 3/8	1 1/16	5/8 Ream

Locking levers with double handles are used where it is advantageous to clamp and lock quickly with high clamping force.

Metric

Part Number*	A	B	C	D	E	F	G	Hub Style
28910	25	25	38	100	6	25	—	Blank
28961	25	25	38	100	6	25	17	M8 Tap
28912	31	28	42	150	9	25	—	Blank
28963	31	28	42	150	9	25	19	M12 Tap
28914	38	31	50	200	13	34	—	Blank
28965	38	31	50	200	13	34	23	M16 Tap
28966	38	31	50	200	13	34	27	16mm Ream

*Dimensions in millimeters

Aluminum & Malleable Clamping Levers



- Material: 319 Aluminum Alloy
Malleable ASTM A47, GR32510
- Finish: Mill
- 3D Solid Models are available in multiple formats from www.jergensinc.com

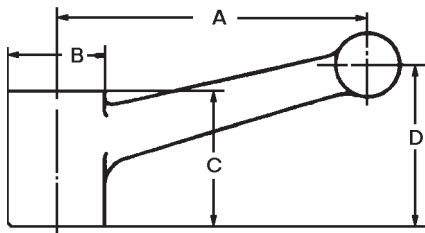

Aluminum

Part Number	A	B	C	D	Wt. (lbs)
16501	2	1	1	1 1/8	.10
16502	4	1 1/2	2	2 1/8	.53
16503	5 9/64	2	2 3/8	2 53/64	1.00

Malleable

Number	Wt. (lbs)
16701	.30
16702	1.50
16703	2.80

HANDLES, LEVERS & CRANKS



Metal Adjustable Handles



For adjustable clamping or tightening controls for limited operating angles. Adjustment of handle position occurs by pulling up on the handle, which disengages the teeth from the locking mechanism, and turning to the desired position. Releasing the handle allows for tightening or loosening.

Tapped Holes:

- Material: Handle, Die Cast Zinc
- Finish: Handle, Plastic Coated
Steel Parts, Black Oxide
- Color: Black Satin Finish

Stainless Steel Tapped Holes:

- Material: Handle, Die Cast Zinc Steel Parts, 303 Stainless Steel
- Finish: Handle, Plastic Coated Steel Parts, Bright
- Color: Black Satin Finish

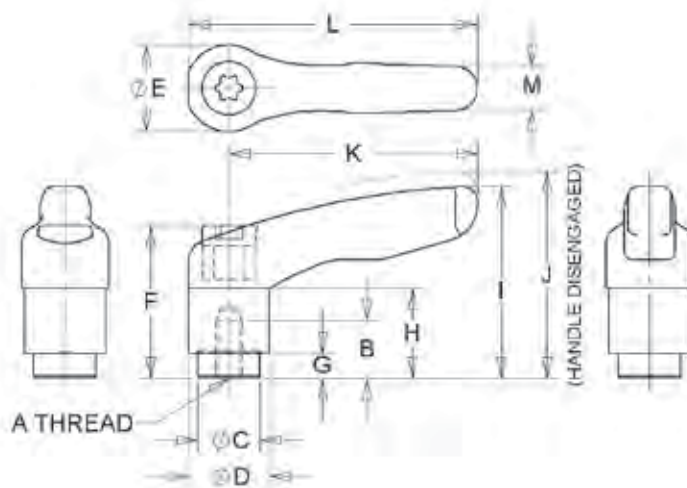

With Tapped Holes

Tapped Part Number	Stainless Tapped Part Number	A	B	C	D	E	F	G	H	I	J	K	L	M
40501	-	8-32	0.35	0.39	0.51	0.57	0.94	0.16	0.59	1.16	1.31	1.57	1.85	0.29
-	40602	10-24	0.35	0.39	0.51	0.57	0.94	0.15	0.59	1.16	1.31	1.57	1.85	0.29
40502	-	10-24	0.35	0.39	0.51	0.57	0.94	0.16	0.59	1.16	1.31	1.57	1.85	0.29
-	40603	1/4-20	0.35	0.39	0.51	0.57	0.94	0.15	0.59	1.16	1.31	1.57	1.85	0.29
40503	-	1/4-20	0.35	0.39	0.51	0.57	0.94	0.16	0.59	1.16	1.31	1.57	1.85	0.29
40504	40604	1/4-20	0.47	0.53	0.70	0.76	1.14	0.25	0.68	1.61	1.77	2.55	2.95	0.37
40505	40605	5/16-18	0.47	0.53	0.70	0.76	1.14	0.25	0.68	1.61	1.77	2.55	2.95	0.37
-	40606	5/16-18	0.55	0.62	0.84	0.90	1.47	0.39	0.94	2.08	2.24	3.14	3.60	0.45
40506	-	5/16-18	0.55	0.70	0.84	0.90	1.47	0.39	0.94	2.08	2.24	3.14	3.60	0.43
-	40607	3/8-16	0.55	0.62	0.84	0.90	1.47	0.39	0.94	2.08	2.24	3.14	3.60	0.45
40507	-	3/8-16	0.55	0.70	0.84	0.90	1.47	0.39	0.94	2.08	2.24	3.74	3.60	0.43
-	40608	3/8-16	0.66	0.74	1.00	1.08	1.67	0.39	1.06	2.40	2.55	3.74	4.28	0.53
40508	-	3/8-16	0.66	0.70	1.00	1.08	1.67	0.39	1.06	2.40	2.55	3.74	4.25	0.51
-	40609	1/2-13	0.66	0.74	1.00	1.08	1.67	0.39	1.06	2.40	2.55	3.74	4.28	0.53
40509	-	1/2-13	0.66	0.70	1.00	1.08	1.67	0.39	1.06	2.40	2.55	3.74	4.25	0.51
40510	40610	1/2-13	0.90	0.90	1.18	1.27	2.00	0.47	1.29	2.85	3.05	4.32	4.97	0.61
40511	40611	5/8-11	0.90	0.90	1.18	1.27	2.00	0.47	1.29	2.85	3.05	4.32	4.97	0.61

Jergens offers 3D models

**for all handles, knobs and handwheels
at www.jergensinc.com**



Metal Adjustable Handles



For adjustable clamping or tightening controls for limited operating angles. Adjustment of handle position occurs by pulling up on the handle, which disengages the teeth from the locking mechanism, and turning to the desired position. Releasing the handle allows for tightening or loosening.

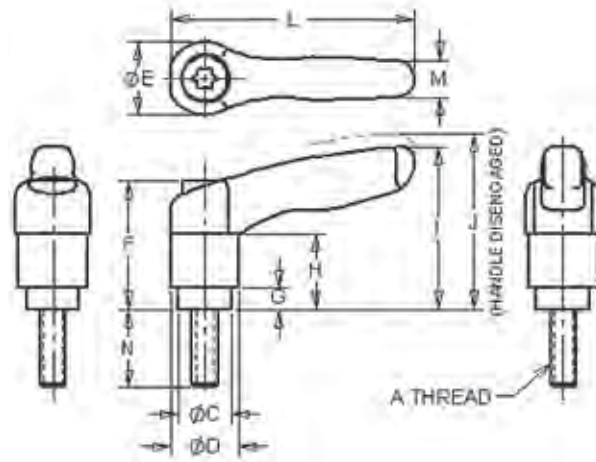

- Material: Handle, Die Cast Zinc
- Finish: Handle, Plastic Coated
Steel Parts, Black Oxide
- Color: Black Satin Finish

Part Number	Thread Size A	Thread Length N	C	D	E	F	G	H	I	J	L	M
40521	10-24	.59	.39	.51	.57	.94	.16	.59	1.16	1.31	1.85	.29
40522	10-24	.98	.39	.51	.57	.94	.16	.59	1.16	1.31	1.85	.29
40523	1/4-20	.78	.39	.51	.57	.94	.16	.59	1.16	1.31	1.85	.29
40524	1/4-20	.98	.39	.51	.57	.94	.16	.59	1.16	1.31	1.85	.29
40525	1/4-20	1.57	.39	.51	.57	.94	.16	.59	1.16	1.31	1.85	.29
40526	1/4-20	.78	.53	.70	.76	1.14	.25	.68	1.61	1.77	2.95	.37
40527	1/4-20	.98	.53	.70	.76	1.14	.25	.68	1.61	1.77	2.95	.37
40528	1/4-20	1.57	.53	.70	.76	1.14	.25	.68	1.61	1.77	2.95	.37
40529	5/16-18	.78	.53	.70	.76	1.14	.25	.68	1.61	1.77	2.95	.37
40530	5/16-18	.98	.53	.70	.76	1.14	.25	.68	1.61	1.77	2.95	.37
40531	5/16-18	1.57	.53	.70	.76	1.14	.25	.68	1.61	1.77	2.95	.37
40532	3/8-16	.98	.70	.84	.90	1.47	.39	.94	2.08	2.24	3.60	.43
40533	3/8-16	1.57	.70	.84	.90	1.47	.39	.94	2.08	2.24	3.60	.43
40534	3/8-16	1.96	.70	.84	.90	1.47	.39	.94	2.08	2.24	3.60	.43
40535	3/8-16	.98	.70	1.00	1.08	1.67	.39	1.06	2.40	2.55	4.25	.51
40536	3/8-16	1.57	.70	1.00	1.08	1.67	.39	1.06	2.40	2.55	4.25	.51
40537	3/8-16	1.96	.70	1.00	1.08	1.67	.39	1.06	2.40	2.55	4.25	.51
40538	1/2-13	.98	.70	1.00	1.08	1.67	.39	1.06	2.40	2.55	4.25	.51
40539	1/2-13	1.57	.70	1.00	1.08	1.67	.39	1.06	2.40	2.55	4.25	.51
40540	1/2-13	1.96	.70	1.00	1.08	1.67	.39	1.06	2.40	2.55	4.25	.51
40541	1/2-13	.98	.90	1.18	1.27	2.00	.47	1.29	2.85	3.05	4.97	.61
40542	1/2-13	1.57	.90	1.18	1.27	2.00	.47	1.29	2.85	3.05	4.97	.61
40543	1/2-13	1.96	.90	1.18	1.27	2.00	.47	1.29	2.85	3.05	4.97	.61
40544	5/8-11	1.37	.90	1.18	1.27	2.00	.47	1.29	2.85	3.05	4.97	.61
40545	5/8-11	1.77	.90	1.18	1.27	2.00	.47	1.29	2.85	3.05	4.97	.61
40546	5/8-11	2.16	.90	1.18	1.27	2.00	.47	1.29	2.85	3.05	4.97	.61
34360	M5	25	10	13	14	24.5	4	14.5	30	33	37	7
34361	M5	35	10	13	14	24.5	4	14.5	30	33	37	7

HANDLES, LEVERS & CRANKS



Metal Adjustable Handles



For adjustable clamping or tightening controls for limited operating angles. Adjustment of handle position occurs by pulling up on the handle, which disengages the teeth from the locking mechanism, and turning to the desired position. Releasing the handle allows for tightening or loosening.

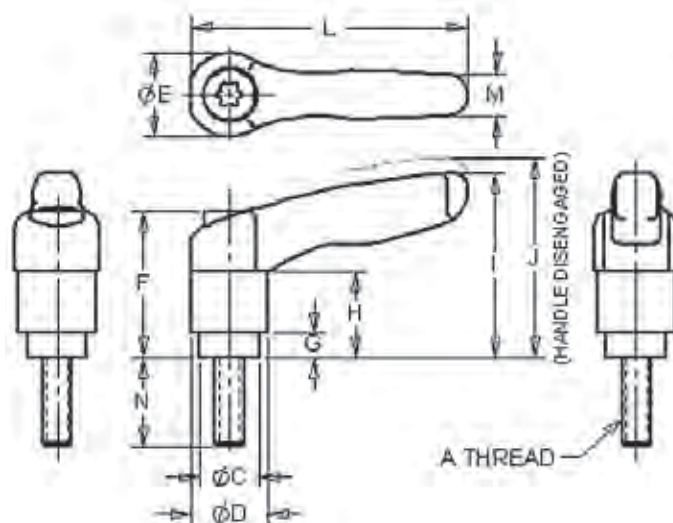

- Handle: Zinc Die Cast, Powder Coated, Satin Black
- Bolts & Internal Parts: Steel Black Oxide Finish; 303 Stainless Steel

With Stainless Steel Stud

Part Number	Thread Size A	Thread Length N	C	D	E	F	G	H	I	J	K	L	M
40621	10-24	.59	.39	.51	.57	.94	.15	.59	1.16	1.31	1.57	1.85	.29
40623	1/4-20	.78	.39	.51	.57	.94	.15	.59	1.16	1.31	1.57	1.85	.29
40625	1/4-20	1.57	.53	.70	.76	1.14	.25	.68	1.61	1.77	2.55	2.95	.37
40630	5/16-18	.78	.53	.70	.76	1.14	.25	.68	1.61	1.77	2.55	2.95	.37
40631	5/16-18	1.57	.53	.70	.76	1.14	.25	.68	1.61	1.77	2.55	2.95	.37
40632	3/8-16	.98	.62	.84	.90	1.47	.39	.94	2.08	2.24	3.14	3.60	.45
40634	3/8-16	1.96	.62	.84	.90	1.47	.39	.94	2.08	2.24	3.14	3.60	.45
40641	1/2-13	.98	.74	1.00	1.08	1.67	.39	1.06	2.40	2.55	3.74	4.28	.53
40643	1/2-13	1.96	.74	1.00	1.08	1.67	.39	1.06	2.40	2.55	3.74	4.28	.53
40644	5/8-11	1.57	.90	1.18	1.27	2.00	.47	1.29	2.85	3.05	4.32	4.97	.61
40646	5/8-11	2.36	.90	1.18	1.27	2.00	.47	1.29	2.85	3.05	4.32	4.97	.61



Adjustable Handle ELESA Original Design

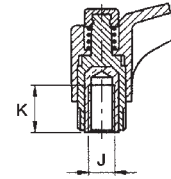
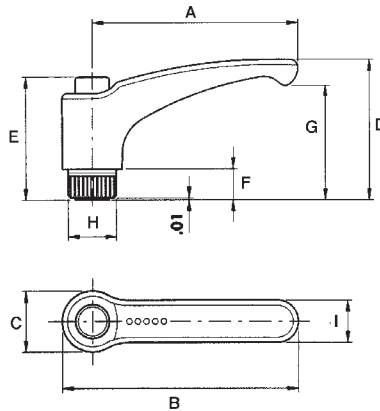

- Material: Glass Fibre Reinforced Technopolymer
- Finish: Body - Gray/Black Matte
Push Button - Orange
- Insert: Brass With Tapped Blind Hole
- Resistant to Solvents, Oils, Greases, and other Chemical Agents
- Optional button colors available upon request (Black, Grey, Yellow, Blue & Red)

With Brass Insert

Brass Insert	Stainless Insert	A	B	C	D	E	F	G	H	I	J	K
34401	—	1.73	2.05	.61	1.28	1.16	.24	.98	.47	.43	10-24	.39
34402	34412	1.73	2.05	.61	1.28	1.16	.24	.98	.47	.43	1/4-20	.39
34403	—	2.48	2.89	.75	1.69	1.48	.31	1.36	.59	.53	1/4-20	.47
34404	34414	2.48	2.89	.75	1.69	1.48	.31	1.36	.59	.53	5/16-18	.51
34406	—	3.07	3.56	.91	2.13	1.85	.47	1.73	.75	.63	3/8-16	.67
34407	34416	3.07	3.56	.91	2.13	1.85	.47	1.73	.75	.63	1/2-13	.67
34408	—	3.74	4.29	1.04	2.54	2.15	.51	2.09	.85	.71	3/8-16	.79
34409	—	3.74	4.29	1.04	2.54	2.15	.51	2.09	.85	.71	1/2-13	.79

Adjustable Handle With Stud ELESA Original Design



- Material: Glass Fibre Reinforced Technopolymer
- Finish: Body - Gray/Black Matte
Push Button - Orange
- Stud: Zinc Plated Steel With Chamfered End.
- Resistant to Solvents, Oils, Greases, and other Chemical Agents
- Optional button colors available upon request (Black, Grey, Yellow, Blue & Red)

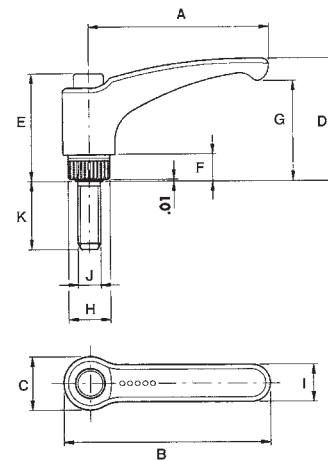

Part Number	A	B	C	D	E	F	G	H	I	J	K
34421	1.73	2.05	.61	1.28	1.16	.24	.98	.47	.43	10-24	.75
34422	1.73	2.05	.61	1.28	1.16	.24	.98	.47	.43	1/4-20	.75
34423	1.73	2.05	.61	1.28	1.16	.24	.98	.47	.43	1/4-20	1
34424	2.48	2.89	.75	1.69	1.48	.31	1.36	.59	.53	5/16-18	.75
34425	2.48	2.89	.75	1.69	1.48	.31	1.36	.59	.53	5/16-18	1
34426	2.48	2.89	.75	1.69	1.48	.31	1.36	.59	.53	5/16-18	1.2
34427	3.07	3.56	.91	2.13	1.85	.47	1.73	.75	.63	3/8-16	1
34428	3.07	3.56	.91	2.13	1.85	.47	1.73	.75	.63	3/8-16	1.2
34429	3.07	3.56	.91	2.13	1.85	.47	1.73	.75	.63	3/8-16	1.5

HANDLES, LEVERS & CRANKS



Plastic Button Head Adjustable Handle With Stud ELESA Original Design

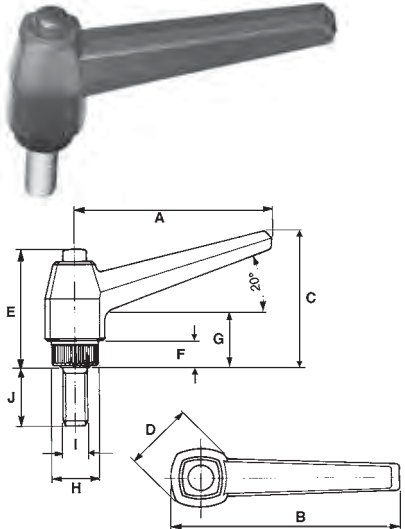

- Material: Glass-Fibre Reinforced Technopolymer Lever Body
- Finish: Black Matte
- Available with a Zinc Plated Steel Stud with a chamfered flat end or with a Brass Insert with a tapped blind hole
- Resistant to Solvents, Oils, Greases, and other Chemical Agents
- Available In Ergostyle®. See Ergostyle Section.
- 3D Solid Models are available in multiple formats from www.jergensinc.com

Part Number	A	B	C	D	E	F	G	H	I	J
34311	1.65	1.96	1.25	0.70	1.14	0.23	0.55	0.47	10-24	0.750
34312	1.65	1.96	1.25	0.70	1.14	0.23	0.55	0.47	1/4-20	0.500
34313	1.65	1.96	1.25	0.70	1.14	0.23	0.55	0.47	1/4-20	0.750
34314	1.65	1.96	1.25	0.70	1.14	0.23	0.55	0.47	1/4-20	1.00
34315	1.65	1.96	1.25	0.70	1.14	0.23	0.55	0.47	1/4-20	1.50
34321	2.48	2.87	1.69	0.90	1.45	0.31	0.66	0.60	1/4-20	0.750
34322	2.48	2.87	1.69	0.90	1.45	0.31	0.66	0.60	1/4-20	1.00
34323	2.48	2.87	1.69	0.90	1.45	0.31	0.66	0.60	1/4-20	1.50
34324	2.48	2.87	1.69	0.90	1.45	0.31	0.66	0.60	5/16-18	0.500
34325	2.48	2.87	1.69	0.90	1.45	0.31	0.66	0.60	5/16-18	0.750
34326	2.48	2.87	1.69	0.90	1.45	0.31	0.66	0.60	5/16-18	1.00
34327	2.48	2.87	1.69	0.90	1.45	0.31	0.66	0.60	5/16-18	1.25
34328	2.48	2.87	1.69	0.90	1.45	0.31	0.66	0.60	5/16-18	1.50
34329	2.48	2.87	1.69	0.90	1.45	0.31	0.66	0.60	5/16-18	2.00
34331	3.15	3.63	2.13	1.10	1.85	0.39	0.86	0.75	3/8-16	0.750
34332	3.15	3.63	2.13	1.10	1.85	0.39	0.86	0.75	3/8-16	1.00
34333	3.15	3.63	2.13	1.10	1.85	0.39	0.86	0.75	3/8-16	1.25
34334	3.15	3.63	2.13	1.10	1.85	0.39	0.86	0.75	3/8-16	1.50
34335	3.15	3.63	2.13	1.10	1.85	0.39	0.86	0.75	3/8-16	2.00
34337	3.15	3.63	2.13	1.10	1.85	0.39	0.86	0.75	1/2-13	1.25
34338	3.15	3.63	2.13	1.10	1.85	0.39	0.86	0.75	1/2-13	1.50
34339	3.15	3.63	2.13	1.10	1.85	0.39	0.86	0.75	1/2-13	2.00
34341	3.94	4.50	2.55	1.30	2.12	0.47	0.98	0.98	1/2-13	1.25
34342	3.94	4.50	2.55	1.30	2.12	0.47	0.98	0.98	1/2-13	1.50
34343	3.94	4.50	2.55	1.30	2.12	0.47	0.98	0.98	1/2-13	2.00

Plastic Button Head Tapped Adjustable Handle

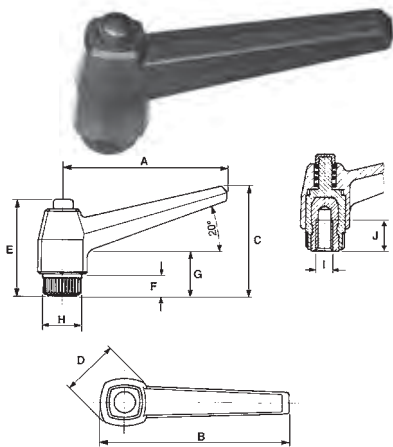

Part Number	A	B	C	D	E	F	G	H	I	J
34301	1.65	1.96	1.25	0.70	1.14	0.23	0.55	0.47	10-24	0.39
34302	1.65	1.96	1.25	0.70	1.14	0.23	0.55	0.47	1/4-20	0.39
34303	2.48	2.87	1.69	0.90	1.45	0.31	0.66	0.60	1/4-20	0.47
34304	2.48	2.87	1.69	0.90	1.45	0.31	0.66	0.60	5/16-18	0.51
34305	3.15	3.62	2.12	1.10	1.85	0.39	0.86	0.74	5/16-18	0.71
34306	3.15	3.62	2.12	1.10	1.85	0.39	0.86	0.74	3/8-16	0.67
34307	3.15	3.62	2.12	1.10	1.85	0.39	0.86	0.74	1/2-13	0.67
34308	3.94	4.48	2.55	1.30	2.12	0.47	0.98	0.98	3/8-16	0.79
34309	3.94	4.48	2.55	1.30	2.12	0.47	0.98	0.98	1/2-13	0.79



Plastic Adjustable Handle With Stainless Steel Stud ELESA Original Design

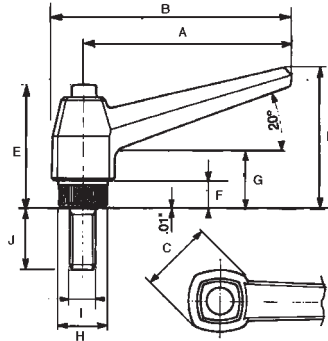

- Material: Lever Body, Glass-Fibre Reinforced Technopolymer
- Finish: Lever Body, Black Matte
- Stainless Steel Stud with chamfered flat end
- Retaining Pin, Glass-Fibre Reinforced Technopolymer integrally molded with the Locking Element
- Push Button, Black Matte Technopolymer
- Resistant to Solvents, Oils, Greases, and other Chemical Agents

Part Number	A	B	C	D	E	F	G	H	I	J
34145	2.48	2.87	0.91	1.69	1.46	0.31	0.67	0.59	5/16-18	0.750
34146	2.48	2.87	0.91	1.69	1.46	0.31	0.67	0.59	5/16-18	1.000
34147	2.48	2.87	0.91	1.69	1.46	0.31	0.67	0.59	5/16-18	1.250

Metric

Part Number*	A	B	C	D	E	F	G	H	I	J
34156	42	50	32	18	29	6	14	12	M6	16
34157	63	73	43	23	37	8	17	15	M8	20
34158	80	92	51	28	47	10	22	19	M10	20
34159	80	92	54	28	47	10	22	19	M12	30

*Dimensions in millimeters

HANDLES, LEVERS & CRANKS

Plastic Button Head Adjustable Tapped Handle With Stainless Steel Insert

Metric
ELESA Original Design

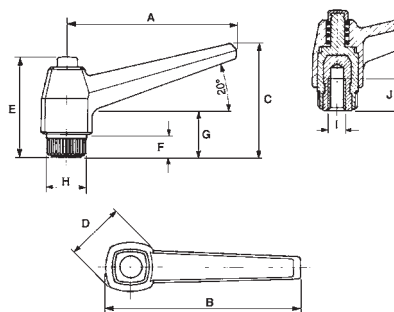

- Material: Glass-Fibre Reinforced Technopolymer Lever Body
- Finish: Black Matte
- Locking Element: Black, Glass-Fibre Reinforced Technopolymer
- Insert: 303 Stainless Steel
- Resistant to Solvents, Oils, Greases, and other Chemical Agents

Part Number*	A	B	C	D	E	F	G	H	I	J
34151	42	50	32	18	29	6	14	12	M6	10
34152	63	73	43	23	37	8	17	15	M8	13
34153	80	92	54	28	47	10	22	19	M10	17

*Dimensions in millimeters



Plastic Button Head Adjustable Handle With Stud

Metric
ELESA Original Design



For adjustable clamping or tightening controls when the operating angle is limited. To adjust during the locking operation, lift the lever in order to disengage the teeth from the locking element and change lever position. The return spring automatically engages the teeth again.

- Material: Glass-Fibre Reinforced Technopolymer Lever Body
- Finish: Black Matte
- Locking Element: Black, Glass-Fibre Reinforced Technopolymer
- Stud: Zinc Plated Steel
- Resistant to Solvents, Oils, Greases, and other Chemical Agents

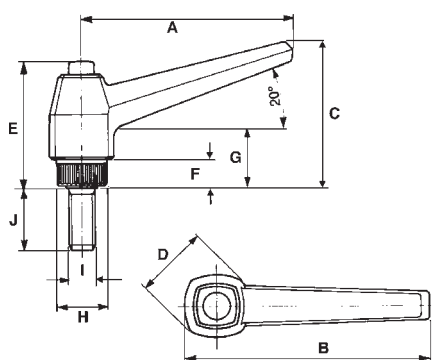

Part Number*	A	B	C	D	E	F	G	H	I	J
34362	42	50	32	18	29	6	14	12	M6	16
34363	42	50	32	18	29	6	14	12	M6	20
34364	42	50	32	18	29	6	14	12	M6	30
34365	42	50	32	18	29	6	14	12	M6	40
34374	63	73	43	23	37	8	17	15	M8	16
34375	63	73	43	23	37	8	17	15	M8	20
34377	63	73	43	23	37	8	17	15	M8	30
34378	63	73	43	23	37	8	17	15	M8	40
34379	63	73	43	23	37	8	17	15	M8	50
34381	80	92	54	28	47	10	22	19	M10	20
34383	80	92	54	28	47	10	22	19	M10	30
34385	80	92	54	28	47	10	22	19	M10	50
34387	80	92	54	28	47	10	22	19	M12	30
34388	80	92	54	28	47	10	22	19	M12	40
34391	100	114	65	33	54	12	25	25	M12	30
34393	100	114	65	33	54	12	25	25	M12	50

*Dimensions in millimeters

Plastic Button Head Tapped Adjustable Handle

Metric
ELESA Original Design



- Material: Glass-Fibre Reinforced Technopolymer Lever Body
- Finish: Black Matte
- Locking Element: Black, Glass-Fibre Reinforced Technopolymer
- Insert: Brass
- Resistant to Solvents, Oils, Greases, and other Chemical Agents

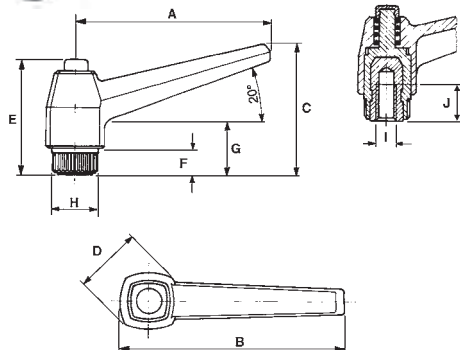

Part Number*	A	B	C	D	E	F	G	H	I	J
34352	42	50	32	18	29	6	14	12	M6	10
34354	63	73	43	23	37	8	17	15	M8	13
34355	80	92	54	28	47	10	22	19	M8	20
34356	80	92	54	28	47	10	22	19	M10	18
34357	80	92	54	28	47	10	22	19	M12	17
34359	100	114	65	33	54	12	25	25	M12	20

*Dimensions in millimeters



Control Lever ELESA Original Design



- Material: Glass Fibre Reinforced Technopolymer
- Finish: Gray/Black Matte
- Removable Boss Caps
- Adaptable For Click Positioning Applications
- Slot Provided For Angle Limit Stop Pins
- Resistant to Solvents, Oils, Greases, and other Chemical Agents
- Optional cap colors available upon request (Black, Grey, Yellow, Blue & Red)

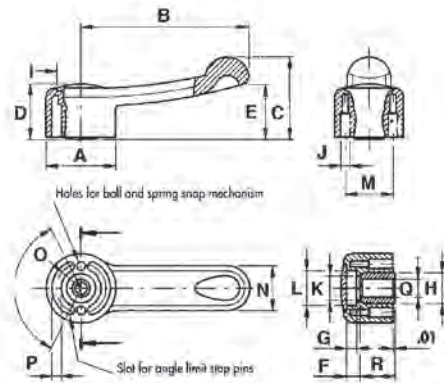

Part Number	A	B	C	D	E	F	G	H	I	J	K	L	M	N	O	P	Q	R
34460	1.46	3.35	1.56	1.04	1.02	.30	.20	.71	1.02	.20	.53	.79	1.02	.91	.54	.17	.315	.69
34461	1.81	4.33	2.13	1.38	1.42	.39	.31	.87	1.24	.24	.67	1.00	1.26	1.14	.69	.26	.472	.87

Machine Guard Handles ELESA Original Design



Closed Style

Open Style

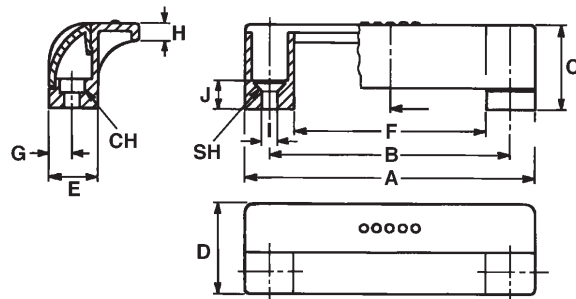

- Material: Glass-Fibre Reinforced Technopolymer
- Finish: Gray/Black Matte
- Handle Shank, Matte Reinforced Polyamide Technopolymer
- Safety Cover Caps, Technopolymer Orange
- Cylindrical Socket Head (CH) or Countersunk Head (SH) Self-Tapping Screws (use 1/4-20 screws)
- Resistant to Solvents, Oils, Greases, and other Chemical Agents
- Optional cap colors available upon request (Black, Grey, Yellow, Blue & Red)

Part Number	Mounting Style	A	B	C	D	E	F	G	H	I	J
34240	CH	4.49	3.68	1.30	1.38	.75	2.91	.37	.28	.26	.43
34241	SH	4.49	3.68	1.30	1.38	.75	2.91	.37	.28	.26	.43
34242*	CH	4.49	3.68	1.30	1.38	.75	2.91	.37	.28	.26	.43
34243*	SH	4.49	3.68	1.30	1.38	.75	2.91	.37	.28	.26	.43

* Open Style

HANDLES, LEVERS & CRANKS



Back Mounted Bridge Handle ELESA Original Design

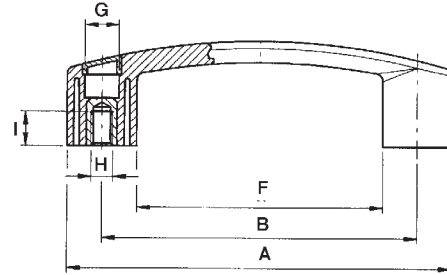
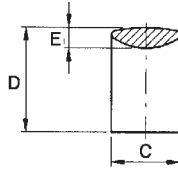

- Material: Glass Fibre Reinforced Technopolymer
- Finish: Gray/Black Matte
- Inserts: Tapped with Blind Hole
- Resistant to Solvents, Oils, Greases, and other Chemical Agents
- Optional cap colors available upon request (Black, Grey, Yellow, Orange, Blue & Red)

Part Number	A	B	C	D	E	F	G	H	I
33875	4.57	3.68	0.87	1.38	0.29	2.83	0.51	1/4-20	0.47
34469	5.67	4.61	1.02	1.54	0.33	3.62	0.53	5/16-18	0.51
33876	7.01	5.91	1.10	1.77	0.37	4.80	0.53	5/16-18	0.51

Front Mounted Bridge Handle ELESA Original Design

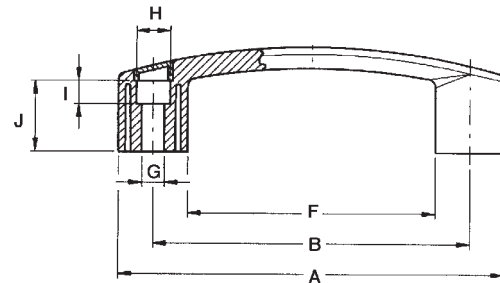
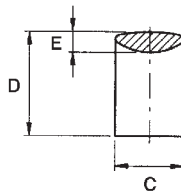

- Material: Glass Fibre Reinforced Technopolymer
- Finish: Gray/Black Matte
- Mounted by Two Through Holes in Front
- Resistant to Solvents, Oils, Greases, and other Chemical Agents
- Optional cap colors available upon request (Black, Grey, Yellow, Orange, Blue & Red)

Part Number	A	B	C	D	E	F	G	H	I	J
34467	4.57	3.68	0.87	1.38	0.29	2.83	0.25	0.41	0.25	0.92
34468	5.67	4.61	1.02	1.54	0.31	3.62	0.33	0.53	0.33	1.04
34479	7.01	5.91	1.10	1.77	0.37	4.8	0.33	0.53	0.55	1.26



Plastic Handle ELESA Original Design



- Material: High Impact Strength Technopolymer
- Finish: Black Matte
- Insert: Brass With Tapped Blind Hole
- Resistant to Solvents, Oils, Greases, and other Chemical Agents

Part Number	A	B	C	D	E	F	G	St lbs
33791	3.94	3.39	1.73	0.55	0.91	1/4-20	0.47	538
33792	5.28	4.61	1.93	0.59	0.98	5/16-18	0.51	594
33793	7.72	7.05	2.24	0.63	1.06	5/16-18	0.51	450

Metric

Part Number*	A	B	C	D	E	F	G	H	St N
33706	100	86	44	14	23	M6	12	73	2400
33705	134	117	49	15	25	M8	13	103	2650
33707	196	179	57	16	27	M8	13	105	2000

*Dimensions in millimeters

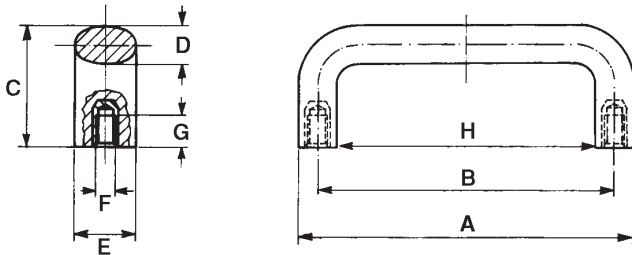
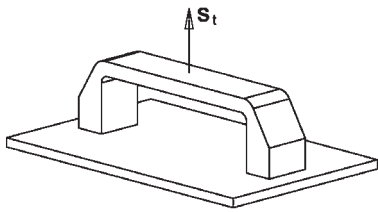

Plastic Handle Metric ELESA Original Design



- Material: High Impact Strength Technopolymer
- Finish: Black Matte
- Insert: Brass With Tapped Blind Hole
- Resistant to Solvents, Oils, Greases, and other Chemical Agents

Part Number*	A	B	C	D	E	F	G	H	St N
33708	134	117	38	7.5	25	102	12	M6	2000
33709	134	117	38	7.5	25	102	12	M8	2000

*Dimensions in millimeters

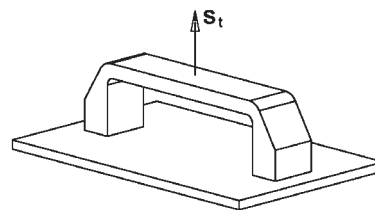
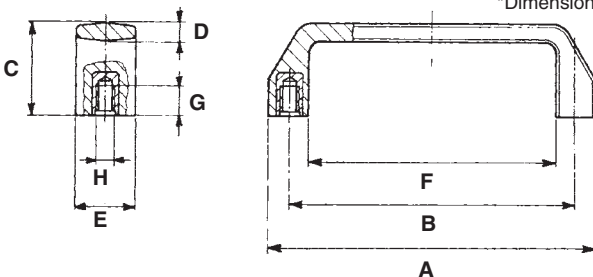

HANDLES, LEVERS & CRANKS



Plastic Pull/Lift Handle ELESA Original Design

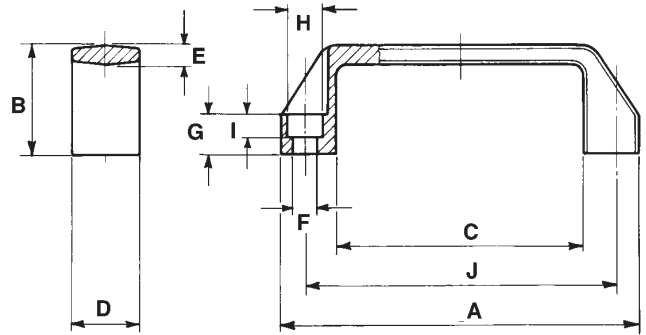
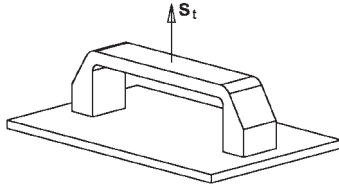

- Material: Glass-Fibre Reinforced Polyamide Technopolymer
- Finish: Black Matte
- Maximum Working Temp. 210°F
- Resistant to Solvents, Oils, Greases, and other Chemical Agents

Part Number	A	B	C	D	E	F	G	H	I	J	St*
33701	4.21	1.42	2.91	0.83	0.24	0.26	0.51	0.41	0.28	3.68	560
33702	5.28	1.61	3.74	1.02	0.28	0.34	0.59	0.53	0.33	4.61	560
33703	5.90	1.77	4.25	1.06	0.28	0.34	0.63	0.53	0.33	5.20	560
33704	7.76	1.97	6.02	1.10	0.31	0.34	0.67	0.53	0.33	7.05	605
33710	10.31	2.13	7.95	1.22	0.35	0.41	0.79	0.65	0.41	9.25	784

* Denotes Stength Table

Aluminum Tubular Handle Elesa Original Design

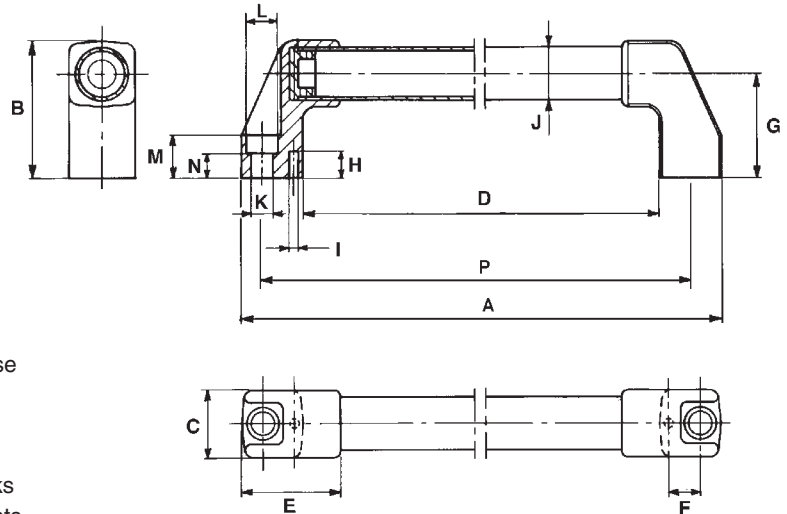

- Material: Tube, Aluminum Handle Shanks, Reinforced Polyamide Technopolymer
- Finish: Tube, Polyurethane coat on an epoxy base Color, Metallflake Graphite
- Handle Shank connection is axially knurled to the tube to prevent tube rotation
- Reference pins for safer positioning of the shanks
- Resistant to wear, scratches, and chemical agents

Part Number	A	B	C	D	E	F	G	H	I	J	K	L	M	N	P
33725	12.76	3.07	1.50	10.00	2.24	.71	2.36	.59	.16	1.18	.41	.63	.98	.59	12
33727	16.69	3.07	1.50	13.94	2.24	.71	2.36	.59	.16	1.18	.41	.63	.98	.59	16
33728	20.63	3.07	1.50	17.87	2.24	.71	2.36	.59	.16	1.18	.41	.63	.98	.59	20
33730	28.50	3.07	1.50	25.75	2.24	.71	2.36	.59	.16	1.18	.41	.63	.98	.59	28

KNOBS

Knobs

Aluminum Hand Knob.....	119–120	Plastic T-Handle	138
Aluminum Hand Knob With Stud.....	119	Plastic Three-Spoked Knob	142
Aluminum Palm Grips.....	144	Plastic Wing Knob	125
Aluminum Palmgrip Knob.....	121	Plastic Wing Knob With Stud	125
Aluminum Star Nuts.....	145	Polished Steel Ball	123
Brass Ball	123	Quick Lock Hand Knob	117
Cast Iron Hand Knob.....	118	Soft Touch Ball	124
Knurled Knob	136	Soft Touch Oval Tapered Knob.....	140
Knurled Knob With Stud	136	Soft Touch Tapered Knob	141
Knurled Steel Knob	121	Speed Bar Knob	122
Knurled Thumb Screw.....	149	Stainless Steel Star Grips.....	146
Stainless Steel Palm Grips.....	143	Steel Knurled Control Knob.....	116
Mushroom Knobs	148	Steel Knurled Control Knob With Stud.....	117
Plain Steel Ball.....	123	Thermoplastic Fluted Knob.....	129
Plastic Ball	124	Wing Nut	126
Plastic Fluted Grip Knob.....	135	Wing Nut With Stud	126
Plastic Fluted Grip Knob With Stud.....	135	Wing Nuts	147
Plastic Fluted Knob	129		
Plastic Four Prong Knob.....	127		
Plastic Four Prong Knob With Extended Prong	127		
Plastic Knurled Torque Knob.....	128		
Plastic Knurled Torque Knob With Stud.....	128		
Plastic Knurled Knob	130		
Plastic Knurled Knob With Stud	130		
Plastic Knurled Grip Knob.....	137		
Plastic Latch Type Lobe Knob	137		
Plastic Lift Knob	139		
Plastic Lobe Knob.....	131–133		
Plastic Lobe Knob With Stud	134		
Plastic Lobe Knob With Stainless Steel Stud.....	134		
Plastic Oval Tapered Knob.....	140		
Plastic Push/Pull Knob.....	142		
Plastic Tapered Knob	139		



Steel Knurled Control Knob



- Material: 1214 Steel
- Finish: Black Oxide
- Knurled Head

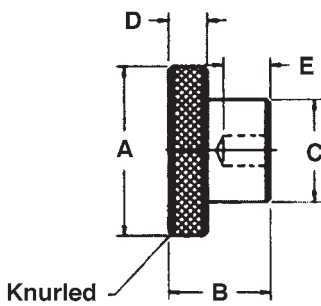

Part Number	A	B	C	D	E	Hole Diameter
21200	3/4	5/8	1/2	1/4	3/8	3/16 Ream
21201	3/4	5/8	1/2	1/4	3/8	10-24 Tap
21202	3/4	5/8	1/2	1/4	3/8	10-24 Thru Hole
21203	3/4	5/8	1/2	1/4	3/8	1/4 Ream
21204	3/4	5/8	1/2	1/4	3/8	1/4-20 Tap
21205	3/4	5/8	1/2	1/4	3/8	1/4-20 Thru Hole
21206	1	3/4	5/8	1/4	1/2	1/4 Ream
21207	1	3/4	5/8	1/4	1/2	1/4-20 Tap
21208	1	3/4	5/8	1/4	1/2	1/4-20 Thru Hole
21209	1	3/4	5/8	1/4	1/2	5/16 Ream
21210	1	3/4	5/8	1/4	1/2	5/16-18 Tap
21211	1	3/4	5/8	1/4	1/2	5/16-18 Thru Hole
21212	1 1/2	1	3/4	5/16	5/8	5/16 Ream
21213	1 1/2	1	3/4	5/16	5/8	5/16-18 Tap
21214	1 1/2	1	3/4	5/16	5/8	5/16-18 Thru Hole
21215	1 1/2	1	3/4	5/16	5/8	3/8 Ream
21216	1 1/2	1	3/4	5/16	5/8	3/8-16 Tap
21217	1 1/2	1	3/4	5/16	5/8	3/8-16 Thru Hole
21218	2	1 1/8	1	3/8	5/8	3/8 Ream
21219	2	1 1/8	1	3/8	5/8	3/8-16 Tap
21220	2	1 1/8	1	3/8	5/8	3/8-16 Thru Hole
21221	2	1 1/8	1	3/8	5/8	1/2 Ream
21222	2	1 1/8	1	3/8	5/8	1/2-13 Tap
21223	2	1 1/8	1	3/8	5/8	1/2-13 Thru Hole
21224	2 1/2	1 1/2	1 1/2	9/16	3/4	1/2 Ream
21225	2 1/2	1 1/2	1 1/2	9/16	3/4	1/2-13 Tap
21226	2 1/2	1 1/2	1 1/2	9/16	3/4	1/2-13 Thru Hole
21227	2 1/2	1 1/2	1 1/2	9/16	3/4	5/8 Ream
21228	2 1/2	1 1/2	1 1/2	9/16	3/4	5/8-11 Tap
21229	2 1/2	1 1/2	1 1/2	9/16	3/4	5/8-11 Thru Hole
21230	3	1 3/4	1 3/4	5/8	1	5/8 Ream
21231	3	1 3/4	1 3/4	5/8	1	5/8-11 Tap
21232	3	1 3/4	1 3/4	5/8	1	5/8-11 Thru Hole
21233	3	1 3/4	1 3/4	5/8	1	3/4 Ream
21234	3	1 3/4	1 3/4	5/8	1	3/4-10 Tap
21235	3	1 3/4	1 3/4	5/8	1	3/4-10 Thru Hole

Note: Also available in Metric and Stainless Steel



Steel Knurled Control Knob With Stud



- Material: 1214 Steel
- Finish: Black Oxide
- Knurled Head

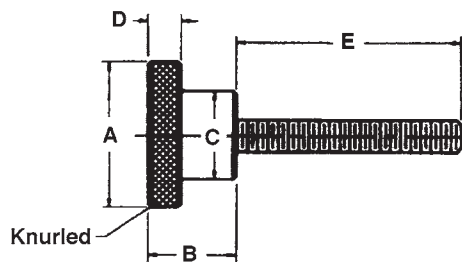

Part Number	A	B	C	D	E	Stud Thread
21240	3/4	5/8	1/2	1/4	1/2	10-24
21241	3/4	5/8	1/2	1/4	1	10-24
21242	3/4	5/8	1/2	1/4	3/4	1/4-20
21243	3/4	5/8	1/2	1/4	1 1/4	1/4-20
21244	1	3/4	5/8	1/4	1 3/4	1/4-20
21245	1	3/4	5/8	1/4	1 3/4	5/16-18
21246	1	3/4	5/8	1/4	3	5/16-18
21247	1 1/2	1	3/4	5/16	1 3/4	5/16-18
21248	1 1/2	1	3/4	5/16	3	5/16-18
21249	1 1/2	1	3/4	5/16	1 3/4	3/8-16
21250	1 1/2	1	3/4	5/16	3	3/8-16
21251	2	1 1/8	1	3/8	1 3/4	3/8-16
21252	2	1 1/8	1	3/8	3	3/8-16
21253	2	1 1/8	1	3/8	1 3/4	1/2-13
21254	2 1/2	1 1/2	1 1/2	9/16	1 3/4	1/2-13
21255	2 1/2	1 1/2	1 1/2	9/16	3	1/2-13
21256	2 1/2	1 1/2	1 1/2	9/16	1 3/4	5/8-11

Quick Lock Hand Knob

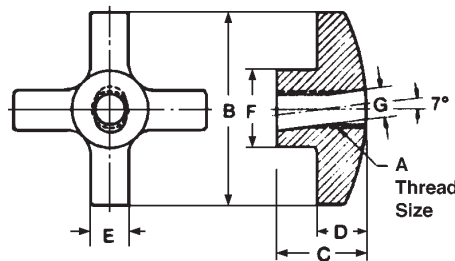
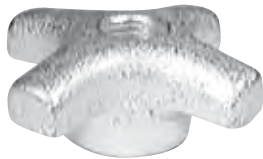

- Material: 40 Grey Iron
- Finish: Zinc Plate
- Thread: Class 2B-UNC
- 3D Solid Models are available in multiple formats from www.jergensinc.com

Used to save time where a knob must be completely removed from the stud. After approximately one-quarter turn of the hand knob, it can be tilted on an angle and removed from the stud. Recommended for light duty applications.

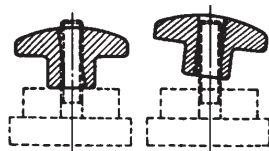

Part Number	Thread Size A	B	C	D	E	F	G	Wt. (lbs)
33901	1/4-20	1 1/8	11/16	5/16	5/16	9/16	17/64	.06
33902	3/8-16	2 3/16	1	1/2	1/2	7/8	25/64	.27
33903	1/2-13	3	1 1/4	5/8	5/8	1 7/16	33/64	.72
33904	5/8-11	3	1 1/4	5/8	5/8	1 7/16	41/64	.69



Cast Iron Hand Knob



- Material: #30 Grey Iron
- Finish: Zinc Plate
- Thread: 2B-UNC
- Ream: +.002
-.000
- Hub: Available Blank, Reamed or Tapped
- 3D Solid Models are available in multiple formats from www.jergensinc.com

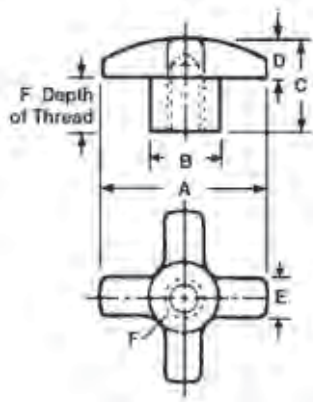

Cast Iron Hand Knob Metric

- Material: #30 Grey Iron
- Finish: Zinc Plate
- Thread: Class 6h
- Ream: -.000
+.05
- Blank Knobs are Zinc Plated
- 3D Solid Models are available in multiple formats from www.jergensinc.com

Part Number	A	B	C	D	E	Hub Style	Depth of Thread F	Wt. (lbs) 10 Pcs.
16305*	1 1/8	5/8	3/4	5/16	5/16	Blank	—	.78
16331*	1 1/8	5/8	11/16	5/16	5/16	1/4 Ream	1/2	.63
16330	1 1/8	5/8	11/16	5/16	5/16	5/16 Ream	1/2	.63
16306*	1 1/8	5/8	11/16	5/16	5/16	1/4-20 Tap	1/2	.63
16307	1 1/8	5/8	11/16	5/16	5/16	5/16-18 Tap	1/2	.63
16308*	1 1/2	11/16	15/16	7/16	3/8	Blank	—	1.56
16309*	1 1/2	11/16	7/8	7/16	3/8	5/16 Ream	9/16	1.30
16310	1 1/2	11/16	7/8	7/16	3/8	3/8 Ream	9/16	1.30
16311*	1 1/2	11/16	7/8	7/16	3/8	5/16-18 Tap	9/16	1.30
16312	1 1/2	11/16	7/8	7/16	3/8	3/8-16 Tap	9/16	1.30
16313*	2	3/4	1 3/16	1/2	1/2	Blank	—	3.00
16314*	2	3/4	1 1/8	1/2	1/2	3/8 Ream	11/16	2.75
16315	2	3/4	1 1/8	1/2	1/2	1/2 Ream	11/16	2.70
16316*	2	3/4	1 1/8	1/2	1/2	3/8-16 Tap	11/16	2.75
16317	2	3/4	1 1/8	1/2	1/2	1/2-13 Tap	11/16	2.70
16318*	2 1/2	1 1/8	1 9/16	5/8	5/8	Blank	—	7.00
16319*	2 1/2	1 1/8	1 1/2	5/8	5/8	1/2 Ream	1	6.00
16320*	2 1/2	1 1/8	1 1/2	5/8	5/8	5/8 Ream	1	5.80
16321*	2 1/2	1 1/8	1 1/2	5/8	5/8	1/2-13 Tap	1	6.00
16322*	2 1/2	1 1/8	1 1/2	5/8	5/8	5/8-11 Tap	1	5.80
16323*	3	1 1/4	1 13/16	9/16	5/8	Blank	—	11.25
16324*	3	1 1/4	1 3/4	9/16	5/8	5/8 Ream	1 1/8	10.00
16325*	3	1 1/4	1 3/4	9/16	5/8	3/4 Ream	1 1/8	8.20
16326	3	1 1/4	1 3/4	9/16	5/8	1/2-13 Tap	1 1/8	10.70
16327*	3	1 1/4	1 3/4	9/16	5/8	5/8-11 Tap	1 1/8	10.25
16328*	3	1 1/4	1 3/4	9/16	5/8	3/4-10 Tap	1 1/8	8.50

*TCMA Standard

*Part Number	A	B	C	D	E	Hub Style	Depth of Thread F
16305	28	16	19	8	8	Blank	—
16354	28	16	17	8	8	6mm Ream	12
16355	28	16	17	8	8	M6 x 1.0 Tap	12
16308	38	17	23	11	9	Blank	—
16359	38	17	22	11	9	8mm Ream	14
16361	38	17	22	11	9	M8 x 1.25 Tap	14
16313	50	19	30	13	13	Blank	—
16364	50	19	28	13	13	10mm Ream	17
16366	50	19	28	13	13	M10 x 1.5 Tap	17
16318	63	29	39	16	16	Blank	—
16369	63	29	38	16	16	12mm Ream	25
16370	63	29	38	16	16	16mm Ream	25
16371	63	29	38	16	16	M12 x 1.75 Tap	25
16372	63	29	38	16	16	M16 x 2.0 Tap	25
16323	75	32	45	14	16	Blank	—
16374	75	32	44	14	16	16mm Ream	28
16375	75	32	44	14	16	20mm Ream	28
16377	75	32	44	14	16	M16 x 2.0 Tap	28
16378	75	32	44	14	16	M20 x 2.5 Tap	28

*Dimensions in millimeters



Aluminum Hand Knob



- Material: Aluminum
- Also available in black, red, blue, clear and gold anodized

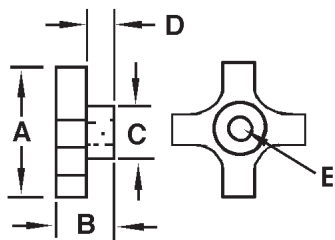

Part Number	A	B	C	D	E
21000	1	7/8	1/2	1/2	Blank
21001	1	7/8	1/2	1/2	1/4-20 Tap
21002	1	7/8	1/2	1/2	1/4-20 Thru Hole
21003	1	7/8	1/2	1/2	1/4 Ream
21004	1 1/2	7/8	5/8	3/8	Blank
21005	1 1/2	7/8	5/8	3/8	5/16-18 Tap
21006	1 1/2	7/8	5/8	3/8	5/16-18 Thru Hole
21007	1 1/2	7/8	5/8	3/8	5/16 Ream
21008	2	1	13/16	1/2	Blank
21009	2	1	13/16	1/2	3/8-16 Tap
21010	2	1	13/16	1/2	3/8-16 Thru Hole
21011	2	1	13/16	1/2	3/8 Ream
21012	2 1/2	1 1/8	1	9/16	Blank
21013	2 1/2	1 1/8	1	9/16	1/2-13 Tap
21014	2 1/2	1 1/8	1	9/16	1/2-13 Thru Hole
21015	2 1/2	1 1/8	1	9/16	1/2 Ream

Note: Also available in metric sizes.

Aluminum Hand Knob With Stud



- Material: Aluminum
- Also available in black, red, blue, clear and gold anodized

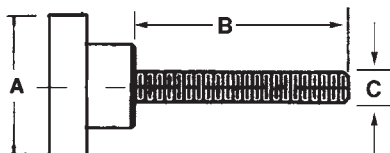

Part Number	A	B	C
21020	1 1/2	1 3/4	1/4-20
21021	1 1/2	3	1/4-20
21022	2	1 3/4	5/16-18
21023	2	3	5/16-18
21024	2 1/2	1 3/4	3/8-16
21025	2 1/2	3	3/8-16
21026	2 1/2	1 3/4	1/2-13
21027	2 1/2	3	1/2-13

Note: Also available in metric sizes.



Aluminum Hand Knob

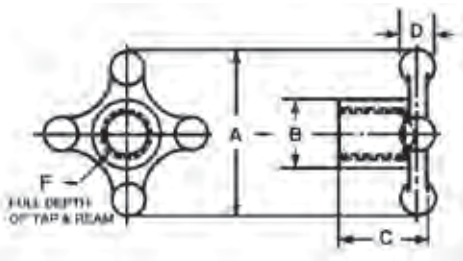

- Material: 319 Aluminum Alloy
- Thread: 2B-UNC
- Ream: +.002
-.000
- 3D Solid Models are available in multiple formats from www.jergensinc.com

Part Number	A	B	C	D	Hub Style	F	Wt. (lbs) 10 Pcs.
21101	1 1/4	9/16	3/4	5/16	Blank	—	.21
21102	1 1/4	9/16	3/4	5/16	1/4 Ream	1/2	.16
21104	1 1/4	9/16	3/4	5/16	1/4-20 Tap	1/2	.16
21105	1 1/4	9/16	3/4	5/16	5/16-18 Tap	1/2	.16
21106	1 1/2	11/16	7/8	3/8	Blank	—	.47
21108	1 1/2	11/16	7/8	3/8	3/8 Ream	5/8	.31
21109	1 1/2	11/16	7/8	3/8	5/16-18 Tap	5/8	.31
21110	1 1/2	11/16	7/8	3/8	3/8-16 Tap	5/8	.31
21111	2 1/8	7/8	1 1/4	1/2	Blank	—	1.10
21112	2 1/8	7/8	1 1/4	1/2	3/8 Ream	7/8	1.00
21113	2 1/8	7/8	1 1/4	1/2	1/2 Ream	7/8	1.00
21114	2 1/8	7/8	1 1/4	1/2	3/8-16 Tap	7/8	1.00
21115	2 1/8	7/8	1 1/4	1/2	1/2-13 Tap	7/8	1.00
21116	3	1 3/8	1 3/4	11/16	Blank	—	3.80
21118	3	1 3/8	1 3/4	11/16	5/8 Ream	1 1/4	3.30
21119	3	1 3/8	1 3/4	11/16	3/4 Ream	1 1/4	3.10
21120	3	1 3/8	1 3/4	11/16	1/2-13 Tap	1 1/4	3.40
21121	3	1 3/8	1 3/4	11/16	5/8-11 Tap	1 1/4	3.30
21122	3	1 3/8	1 3/4	11/16	3/4-10 Tap	1 1/4	3.10

Aluminum Hand Knob Metric

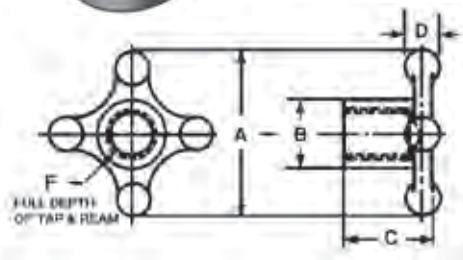

- Material: 319 Aluminum Alloy
- Thread: Class 6h
- Ream: +.05
-.000

*Part Number	A	B	C	D	Hub Style	F
21101	31	14	19	8	Blank	—
21152	31	14	19	8	6mm Ream	13
21154	31	14	19	8	M6 Tap	13
21155	31	14	19	8	M8 Tap	13
21106	38	17	22	9	Blank	—
21158	38	17	22	9	10mm Ream	16
21159	38	17	22	9	M8 Tap	16
21160	38	17	22	9	M10 Tap	16
21111	53	22	32	12	Blank	—
21162	53	22	32	12	10mm Ream	22
21163	53	22	32	12	12mm Ream	22
21164	53	22	32	12	M10 Tap	22
21165	53	22	32	12	M12 Tap	22
21116	75	34	44	17	Blank	—
21168	75	34	44	17	16mm Ream	32
21169	75	34	44	17	20mm Ream	32
21170	75	34	44	17	M12 Tap	32
21171	75	34	44	17	M16 Tap	32
21172	75	34	44	17	M20 Tap	32

*Dimensions in millimeters



Aluminum Palmgrip Knob



Full Depth of Tap and Ream

- Material: 319 Aluminum Alloy
- Finish: Tumble
- Thread: 2B-UNC or Class 6h
- Ream: +.002
-.000
- Metric Ream: +.05
-.000
- 3D Solid Models are available in multiple formats from www.jergensinc.com

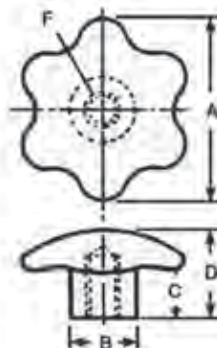

Inch

Part Number	A	B	C	D	F	Hub Style
20901	1 1/2	27/32	7/8	3/8	—	Blank
20902	1 1/2	27/32	7/8	1 5/16	3/4	1/4 Ream
20903	1 1/2	27/32	7/8	1 5/16	3/4	1/4-20 Tap
20904	2	1	7/8	1 19/32	—	Blank
20905	2	1	7/8	1 1/2	3/4	3/8 Ream
20906	2	1	7/8	1 1/2	3/4	3/8-16 Tap
20907	2 3/4	1 3/16	1 1/8	1 31/32	—	Blank
20908	2 3/4	1 3/16	1 1/8	1 7/8	1 1/4	1/2 Ream
20909	2 3/4	1 3/16	1 1/8	1 7/8	1 1/4	1/2-13 Tap
20910	3 1/2	1 1/4	1	1 13/16	—	Blank
20911	3 1/2	1 1/4	1	1 3/4	1 1/4	1/2 Ream
20912	3 1/2	1 1/4	1	1 3/4	1 1/4	1/2-13 Tap

Metric

*Part Number	A	B	C	D	F	Hub Style
20901	38	19	22	34	—	Blank
20952	38	19	22	33	19	6mm Ream
20953	38	19	22	33	19	M6 Tap
20904	50	25	22	40	—	Blank
20955	50	25	22	38	19	10mm Ream
20956	50	25	22	38	19	M10 Tap
20907	69	30	29	49	—	Blank
20958	69	30	29	47	31	12mm Ream
20959	69	30	29	47	31	M12 Tap
20910	88	31	25	45	—	Blank
20961	88	31	25	44	31	12mm Ream
20962	88	31	25	44	31	M12 Tap

*Dimensions in millimeters

Knurled Steel Knob

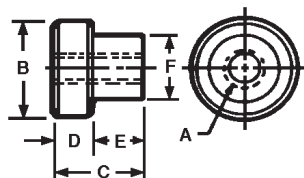

- Material: Low Carbon Steel
- Finish: Black Oxide
- Thread: 2B-UNC or Class 6h
- 3D Solid Models are available in multiple formats from www.jergensinc.com

Inch

Part Number	A	B	C	D	E	F
27901	10-24	3/4	5/8	1/4	3/8	7/16
27902	1/4-20	1	3/4	1/4	1/2	5/8
27903	3/8-16	1 1/4	1 1/8	1/2	5/8	3/4
27904	1/2-13	1 1/2	1 1/4	1/2	3/4	1
27905	5/8-11	2	1 3/4	5/8	1 1/8	1 1/4
27906	3/4-10	2 1/2	2 1/4	5/8	1 5/8	1 1/2

Metric

*Part Number	A	B	C	D	E	F
27951	M5 x 0.8	19	16	6	9	11
27952	M6 x 1.0	25	19	6	13	16
27953	M10 x 1.5	31	28	13	16	19
27954	M12 x 1.75	38	31	13	19	25
27955	M16 x 2.0	50	44	16	28	31
27956	M20 x 2.5	63	57	16	41	38

*Dimensions in millimeters



Speed Bar Knob



Speed Bar Knobs offer the ultimate in strength to hold down covers and clamp heavy work pieces. Insert bar between four vertical prongs for maximum leverage and holding force. One extra long prong is available on part numbers **40706** and **40707** for use with a crank handle.

- Material: Malleable ASTM 32510
- Finish: Mill
- Thread: 2B-UNC or Metric Class 6h
- 3D Solid Models are available in multiple formats from www.jergensinc.com

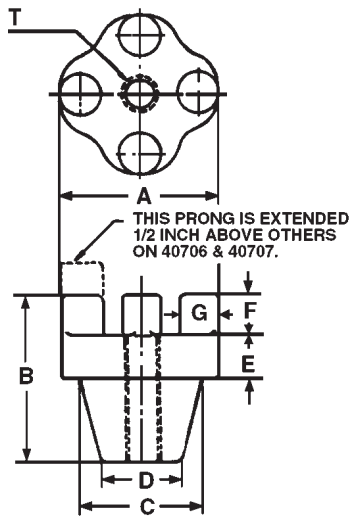

Inch

Part Number	A	B	C	D	E	F	G	T	Wt. (lbs)
40701	2	2 1/8	1 1/4	1 1/8	1/2	3/4	1/2	Blank	0.80
40711	2	2 1/8	1 1/4	1 1/8	1/2	3/4	1/2	3/8-16	0.76
40702	2	2 1/8	1 1/4	1 1/8	1/2	3/4	1/2	1/2-13	0.72
40712	2	2 1/8	1 1/4	1 1/8	1/2	3/4	1/2	5/8-11	0.68
40703	2 1/2	2 3/8	1 3/4	1 1/2	9/16	7/8	5/8	Blank	1.56
40713	2 1/2	2 3/8	1 3/4	1 1/2	9/16	7/8	5/8	1/2-13	1.48
40704	2 1/2	2 3/8	1 3/4	1 1/2	9/16	7/8	5/8	5/8-11	1.44
40705	2 1/2	2 3/8	1 3/8	1 1/2	9/16	7/8	5/8	3/4-10	1.44
40706	3 1/2	2 3/8	2 3/8	2 1/8	1/2	7/8	5/8	Blank	2.50
40715	3 1/2	2 3/8	2 3/8	2 1/8	1/2	7/8	5/8	7/8-09	2.38
40707	3 1/2	2 3/8	2 3/8	2 1/8	1/2	7/8	5/8	1-8	2.25

Metric

Part Number**	A	B	C	D	E	F	G	T
40701	50	53	31	28	12	19	12	Blank
40752	50	53	31	28	12	19	12	M12
40703	63	59	44	38	14	22	16	Blank
40754	63	59	44	38	14	22	16	M16
40755	63	59	44	38	14	22	16	M20
40706*	88	59	59	53	12	22	16	Blank
40757*	88	59	59	53	12	22	16	M24

*Note: One extra long prong is available on part numbers 40706 and 40757 for use with a crank handle.

**Dimensions in millimeters



Plain Steel Ball



- Material: Carbon Steel
- Finish: Black Oxide
- Available Tapped or Blank
- 3D Solid Models are available in multiple formats from www.jergensinc.com

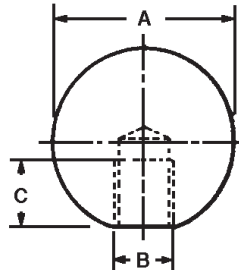

Part Number	A	B	C
36511	1 1/2	Blank	—
36512	1 1/2	3/8-16	5/8
36513	2	Blank	—
36514	2	1/2-13	3/4
36515	2	5/8-11	7/8

Polished Steel Ball



- Material: Steel
- Finish: Polished

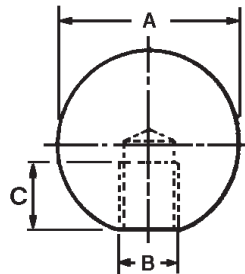

Part Number	A	B	C
36520	3/4	10-32	3/8
36521	1	10-32	3/8
36522	1	1/4-20	1/2
36523	1	5/16-18	1/2
36524	1	3/8-16	1/2
36525	1 3/8	1/4-20	5/8
36526	1 3/8	5/16-18	5/8
36527	1 3/8	3/8-16	5/8
36528	1 3/8	1/2-13	5/8
36529	1 7/8	3/8-16	3/4
36530	1 7/8	1/2-13	3/4
36531	1 7/8	5/8-11	3/4

Brass Ball



- Material: Brass
- Finish: Polished
- Water Resistant

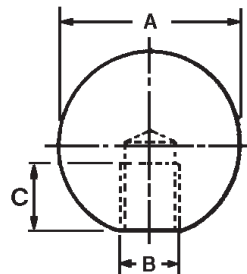

Part Number	A	B	C
36540	3/4	10-32	3/8
36541	1	10-32	3/8
36542	1	1/4-20	1/2
36543	1	5/16-18	1/2
36544	1	3/8-16	1/2
36545	1 3/8	1/4-20	5/8
36546	1 3/8	5/16-18	5/8
36547	1 3/8	3/8-16	5/8
36548	1 3/8	1/2-13	5/8
36549	1 7/8	3/8-16	3/4
36550	1 7/8	1/2-13	3/4
36551	1 7/8	5/8-11	3/4



Plastic Ball



- Material: Plastic, Black
- Insert: Brass
- Finish: Tumble, Sand, & Buff
- 3D Solid Models are available in multiple formats from www.jergensinc.com

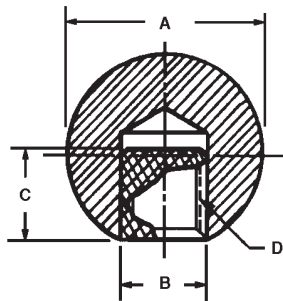

Black Part Number	A	B	C	Brass Insert D
31301	3/4	1/4	5/16	10-32
31316	3/4	1/4	5/16	1/4-20
31317	1	1/2	1/2	10-32
31302	1	1/2	7/16	1/4-20
31308	1	1/2	7/16	5/16-18
31303	1	1/2	1/2	3/8-16
31318	1 3/8	5/8	5/8	1/4-20
31309	1 3/8	5/8	7/16	5/16-18
31304	1 3/8	5/8	1/2	3/8-16
31310	1 3/8	5/8	1/2	3/8-24
31305	1 3/8	5/8	5/8	1/2-13
31311	1 3/8	5/8	5/8	1/2-20
31319	1 5/8	11/16	5/8	5/16-18
31314	1 5/8	11/16	1/2	3/8-16
31315	1 5/8	11/16	5/8	1/2-13
31320	1 7/8	3/4	7/16	5/16-18
31312	1 7/8	3/4	1/2	3/8-16
31306	1 7/8	3/4	5/8	1/2-13
31313	1 7/8	3/4	5/8	1/2-20
31307	1 7/8	3/4	3/4	5/8-18

Soft Touch Ball

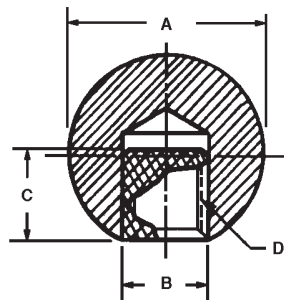

- Material: Soft Touch Plastic
- Finish: Black Matte
- Insert: Brass
- Also available in red, blue, yellow, and green (250 piece minimum)

Part Number	A	B	C	Insert D
31330	1 1/2	1 15/64	5/8	1/4-20 x 5/8
31331	1 1/2	1 15/64	5/8	5/16-18 x 5/8
31332	1 1/2	1 15/64	5/8	3/8-16 x 5/8
31333	1 1/2	1 15/64	5/8	1/2-13 x 5/8

This Ball Knob has a soft touch material which enables the operator to get a better grip on the knob for many different types of operations.



Plastic Wing Knob ELESA Original Design Metric



- Material: Glass-Fibre Reinforced Black Technopolymer
- Finish: Black Matte
- Insert: Brass with tapped blind hole
- Resistant to Solvents, Oils, Greases, and other Chemical Agents

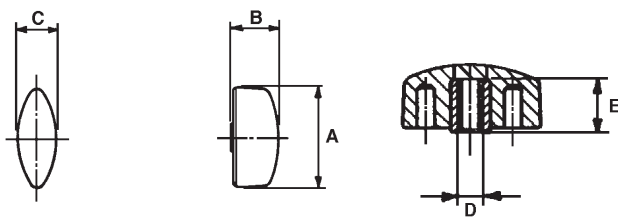

Part Number*	A	B	C	D	E
33776	26	13	11	M5	5
33777	32	15	13	M6	8
33778	40	17	15.5	M8	8

*Dimensions in millimeters

Plastic Wing Knob With Stud ELESA Original Design



- Material: Glass-Fibre Reinforced Black Technopolymer
- Finish: Black Matte
- Zinc-Plated Steel Stud with chamfered flat end
- Resistant to Solvents, Oils, Greases, and other Chemical Agents

Inch

Part Number	A	B	C	D	E
33765	1.02	.51	.43	10-32	.500
33766	1.02	.51	.43	10-32	.750
33767	1.26	.59	.51	1/4-20	.500
33768	1.26	.59	.51	1/4-20	.750
33769	1.26	.59	.51	1/4-20	1.000
33770	1.57	.67	.61	5/16-18	.750
33771	1.57	.67	.61	5/16-18	1.000

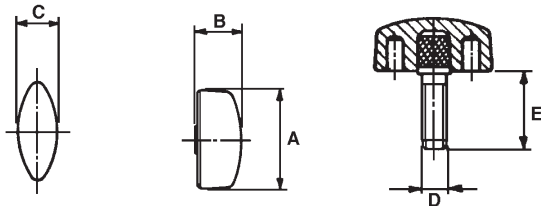

Metric

Part Number*	A	B	C	D	E
33781	26	13	11	M5	16
33782	32	15	13	M6	16
33783	32	15	13	M8	16
33784	40	17	15.5	M8	25
33785	40	17	15.5	M10	30

*Dimensions in millimeters



Wing Nut ELESA Original Design

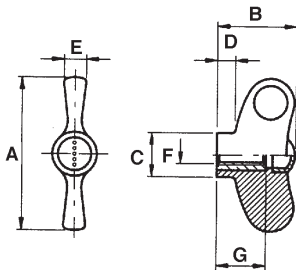

- Material: Glass Fibre Reinforced Technopolymer
- Finish: Gray/Black Matte
- Insert: Brass With Tapped Hole
- Resistant to Solvents, Oils, Greases, and other Chemical Agents
- Optional cap colors available upon request (Black, Grey, Yellow, Blue & Red)

Part Number	A	B	C	D	E	F	G
34450	2.17	1.1	0.63	0.26	0.31	1/4-20	0.71
34451	2.17	1.1	0.63	0.26	0.31	5/16-18	0.71
34452	2.76	1.42	0.79	0.31	0.39	5/16-18	0.79
34453	2.76	1.42	0.79	0.31	0.39	3/8-16	0.79

Wing Nut With Stud ELESA Original Design

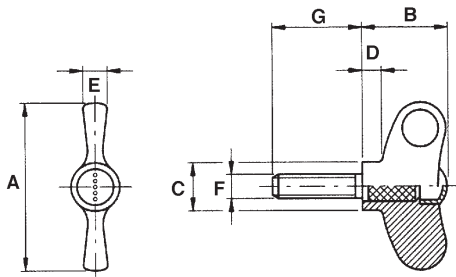

- Material: Glass Fibre Reinforced Technopolymer
- Finish: Gray/Black Matte
- Stud: Zinc Plated Threaded Steel With Chamfered End
- Resistant to Solvents, Oils, Greases, and other Chemical Agents
- Optional cap colors available upon request (Black, Grey, Yellow, Blue & Red)

Part Number	A	B	C	D	E	F	G
34455	2.17	1.10	.63	.26	.31	5/16-18	1.00
34456	2.17	1.10	.63	.26	.31	5/16-18	1.50
34457	2.76	1.42	.79	.31	.39	3/8-16	1.00
34458	2.76	1.42	.79	.31	.39	3/8-16	1.50



Plastic Four Prong Knob

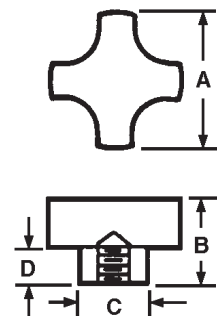

- Material: Plastic
- Finish: Tumble
- Insert: Brass
- Excellent gripping action for turning and tightening uses: adjusting devices, tripods, lawn mower height adjustments, valve controls, etc.
- 3D Solid Models are available in multiple formats from www.jergensinc.com

Part Number	Insert Thread and Depth	A	B	C	D
32201	1/4-20 x 7/16	1 1/4	7/8	5/8	3/8
32270	5/16-18 x 7/16	1 1/4	7/8	5/8	3/8
32202*	1/4-20 x 1/2	1 1/4	7/8	5/8	3/8
32271	1/4-20 x 7/16	1 3/4	1	13/16	1/2
32203	5/16-18 x 7/16	1 3/4	1	13/16	1/2
32204*	5/16-18 x 5/8	1 3/4	1	13/16	1/2
32272*	1/4-20 x 5/8	1 3/4	1	13/16	1/2
32205	3/8-16 x 1/2	1 3/4	1	13/16	1/2
32206*	3/8-16 x 5/8	1 3/4	1	13/16	1/2
32207	3/8-16 x 1/2	2 1/4	1 1/8	1	9/16
32273	5/16-18 x 1/2	2 1/4	1 1/8	1	9/16
32208*	3/8-16 x 5/8	2 1/4	1 1/8	1	9/16
32274*	5/16-18 x 5/8	2 1/4	1 1/8	1	9/16
32209	1/2-13 x 5/8	2 1/4	1 1/8	1	9/16
32210*	1/2-13 x 5/8	2 1/4	1 1/8	1	9/16

*Indicates knobs with through clearance hole.

Plastic Four Prong Knob With Extended Prong

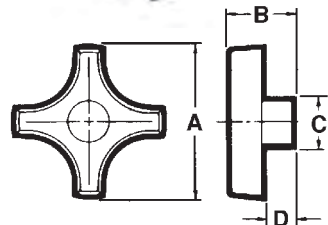

- Material: Polypropylene
- Finish: Tumble
- Insert: Brass

Part Number	A	B	C	D	Insert
32260	3	1 1/4	7/8	5/8	1/4-20
32261*	3	1 1/4	7/8	5/8	1/4-20
32262	3	1 1/4	7/8	5/8	5/16-18
32263*	3	1 1/4	7/8	5/8	5/16-18
32264	3	1 1/4	7/8	5/8	3/8-16
32265*	3	1 1/4	7/8	5/8	3/8-16

* Through Hole Style



Plastic Knurled Torque Knob

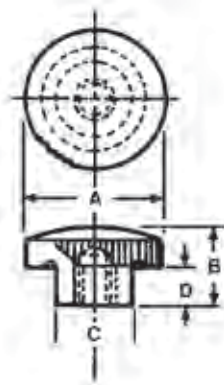

- Material: Plastic
- Finish: Tumble
- Knurled edge for non-slip grip
- Insert Threads: Brass
- 3D Solid Models are available in multiple formats from www.jergensinc.com

Part Number	Insert Thread and Depth	A	B	C	D
32324	8-32 x 5/16	3/4	9/16	5/8	—
32325	10-32 x 5/16	3/4	9/16	5/8	—
32328	1/4-20 x 3/8	3/4	9/16	5/8	—
32301	10-32 x 5/16	1	21/32	5/8	5/16
32303	1/4-20 x 3/8	1	21/32	5/8	5/16
32305	1/4-20 x 7/16	1 3/8	25/32	3/4	3/8
32308	5/16-18 x 7/16	1 3/8	25/32	3/4	3/8
32310	3/8-16 x 3/8	1 3/8	25/32	3/4	3/8
32311	5/16-18 x 7/16	1 7/8	1	1	1/2
32312	3/8-16 x 1/2	1 7/8	1	1	1/2
32315	Bushing*	1 7/8	1	1	1/2

*.377 I.D. x 1/2" O.D. x 1/2" long plain hole brass bushing, drilled and tapped for one #10-32 set screw.

Plastic Knurled Torque Knob With Stud

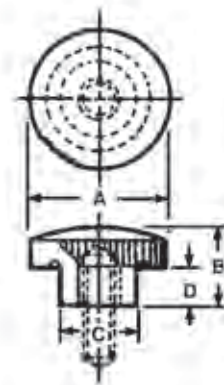

- Material: Plastic
- Finish: Tumble
- Knurled edge for non-slip grip
- Stud Threads: Zinc Plated Steel
- 3D Solid Models are available in multiple formats from www.jergensinc.com

Part Number	Stud Thread and Length	A	B	C	D
32326	10-32 x 1/2	3/4	9/16	5/8	—
32327	10-32 x 1	3/4	9/16	5/8	—
32329	1/4-20 x 1/2	3/4	9/16	5/8	—
32330	1/4-20 x 1	3/4	9/16	5/8	—
32302	10-32 x 1	1	21/32	5/8	5/16
32304	1/4-20 x 1	1	21/32	5/8	5/16
32334	5/16-18 x 1	1	21/32	5/8	5/16
32306	1/4-20 x 1	1 3/8	25/32	3/4	3/8
32307	1/4-20 x 2	1 3/8	25/32	3/4	3/8
32331	5/16-18 x 1	1 3/8	25/32	3/4	3/8
32309	5/16-18 x 2	1 3/8	25/32	3/4	3/8
32332	3/8-16 x 1	1 3/8	25/32	3/4	3/8
32333	5/16-18 x 1	1 7/8	1	1	1/2
32313	3/8-16 x 1	1 7/8	1	1	1/2



Plastic Fluted Knob



- Material: Plastic
- Finish: Tumble
- Insert Threads: Brass
- Bushing: Brass
- Stud Threads: Zinc Plated Steel
- For heavy torque applications, clamping devices, adjusting rods
- 3D Solid Models are available in multiple formats from www.jergensinc.com

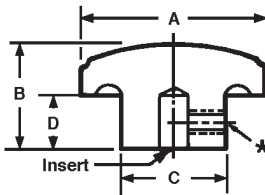

Part Number	Insert Thread and Depth	Stud Thread and Length	A	B	C	D
32320	1/4-20 x 7/16	—	1 3/8	27/32	27/32	25/64
32340	—	1/4-20 x 1	1 3/8	27/32	27/32	25/64
32321	5/16-18 x 7/16	—	1 3/8	27/32	27/32	25/64
32341	—	5/16-18 x 1	1 3/8	27/32	27/32	25/64
32342	—	3/8-16 x 1	1 3/8	27/32	27/32	25/64
32343	—	1/4-20 x 1	1 3/4	1 1/16	1 1/16	1/2
32322	5/16-18 x 7/16	—	1 3/4	1 1/16	1 1/16	1/2
32344	—	5/16-18 x 1	1 3/4	1 1/16	1 1/16	1/2
32323	3/8-16 x 1/2	—	1 3/4	1 1/16	1 1/16	1/2
32345	—	3/8-16 x 1	1 3/4	1 1/16	1 1/16	1/2
32346	1/4-20 x 7/16	—	1 3/4	1 1/16	1 1/16	1/2
32316	3/8-16 x 1/2	—	2 3/8	1 5/16	1 1/4	5/8
32347	5/16-18 x 7/16	—	2 3/8	1 5/16	1 1/4	5/8
32317	—	3/8-16 x 1	2 3/8	1 5/16	1 1/4	5/8
32318	—	3/8-16 x 2	2 3/8	1 5/16	1 1/4	5/8
32348	—	5/16-18 x 1	2 3/8	1 5/16	1 1/4	5/8
32319	Bushing*	—	2 3/8	1 5/16	1 1/4	5/8

*.377 I.D. x 1/2" O.D. x 1/2" deep plain brass bushing, drilled and tapped for one #10-32 set screw.

Thermoplastic Fluted Knob

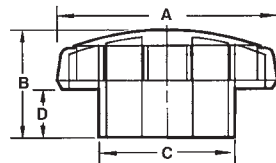
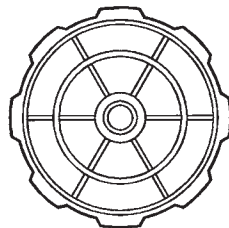

- Material: Thermoplastic
- Finish: Black Matte
- Insert: Brass
- Textured surface resists scratches, nicks, and fingerprints
- Also available in red, blue, yellow, and green
- A standard 1" stud is available, other lengths available upon request.

Part Number	A	B	C	D	Insert
32350	3 1/4	1 3/8	2	3/4	1/4-20 x 5/8
32351	3 1/4	1 3/8	2	3/4	5/16-18 x 3/4
32352	3 1/4	1 3/8	2	3/4	3/8-16 x 7/8



**Plastic Knurled Knob
ELESA Original Design**

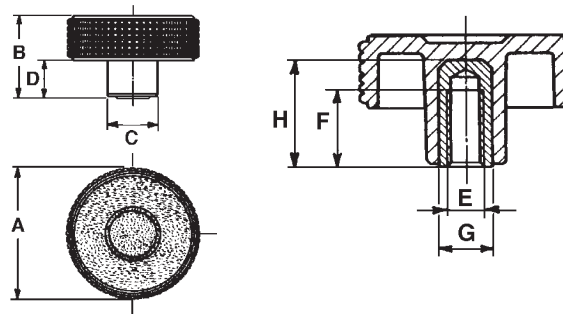

- Material: High Impact Strength Technopolymer
- Finish: Black Matte
- Brass Insert with tapped or plain blind hole
- Knobs with plain blind hole complete with set screw
- Resistant to Solvents, Oils, Greases, and other Chemical Agents

Part Number	A	B	C	D	E	Set Screw	F	G	H
33801	1.22	.87	.59	.35	1/4-20	—	.47	—	—
33802	1.57	.94	.67	.43	1/4	10-32	.55	.47	.67
33803	1.57	.94	.67	.43	1/4-20	—	.47	—	—
33804	1.57	.94	.67	.43	5/16-18	—	.51	—	—
33805	1.97	1.18	.79	.53	3/8	10-32	.79	.63	.98
33806	1.97	1.18	.79	.53	5/16-18	—	.70	—	—
33807	1.97	1.18	.79	.53	3/8-16	—	.67	—	—
33808	2.36	1.38	.91	.59	3/8	1/4-20	.79	.63	1.18
33809	2.36	1.38	.91	.59	3/8-16	—	.79	—	—
33810	2.36	1.38	.91	.59	1/2-13	—	.79	—	—

**Plastic Knurled Knob
With Stud
ELESA Original Design**

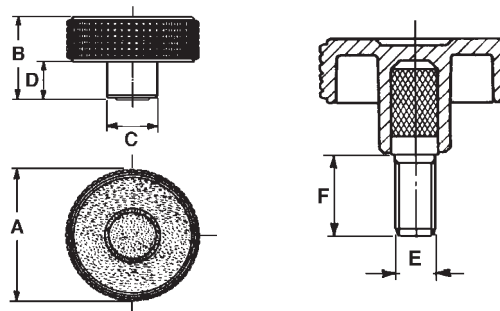

- Material: High Impact Strength Technopolymer
- Finish: Black Matte
- Stud: Zinc Plated Steel with chamfered flat end
- Resistant to Solvents, Oils, Greases, and other Chemical Agents

Part Number	A	B	C	D	E	F
33811	1.22	.87	.59	.35	1/4-20	.500
33812	1.22	.87	.59	.35	1/4-20	.750
33813	1.57	.94	.67	.43	1/4-20	.750
33814	1.57	.94	.67	.43	1/4-20	1.00
33815	1.57	.94	.67	.43	5/16-18	.750
33816	1.57	.94	.67	.43	5/16-18	1.00
33817	1.97	1.18	.79	.53	3/8-16	1.00
33818	1.97	1.18	.79	.53	3/8-16	1.25
33819	2.36	1.38	.91	.59	3/8-16	1.00
33820	2.36	1.38	.91	.59	3/8-16	1.25



Plastic Lobe Knob ELESA Original Design



- Material: High Impact Strength Technopolymer
- Finish: Black
- Insert: Brass with tapped or plain blind hole
- Knobs with plain blind hole
- Resistant to Solvents, Oils, Greases, and other Chemical Agents

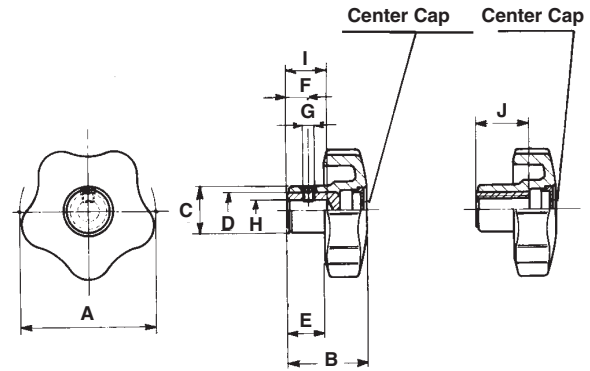

Part Number	A	B	C	D	E	F	Set Screw G	Mounting Holes (H)		I	J
								Plain	Tapped		
33840	0.98	0.75	0.51	0.28	0.31	—	—	—	10-32	—	0.39
33841	1.26	0.91	0.59	—	0.39	—	—	—	1/4-20	—	0.47
33842	1.26	0.91	0.59	0.47	0.39	0.2	10-32	1/4	—	—	0.47
33843	1.57	1.06	0.67	—	0.47	—	—	—	1/4-20	—	0.71
33844	1.57	1.06	0.67	—	0.47	—	—	—	5/16-18	—	0.71
33845	1.57	1.06	0.67	0.47	0.47	0.24	10-32	1/4	—	0.55	—
33846	1.57	1.06	0.67	0.55	0.47	0.24	10-32	5/16	—	0.59	—
33847	1.97	1.26	0.75	—	0.55	—	—	—	5/16-18	—	0.79
33848	1.97	1.26	0.75	—	0.55	—	—	—	3/8-16	—	0.79
33849	1.97	1.26	0.75	0.55	0.55	0.28	10-32	5/16	—	0.63	—
33850	1.97	1.26	0.75	0.63	0.55	0.28	10-32	3/8	—	0.63	—
33851	2.48	1.46	0.87	—	0.63	—	—	—	3/8-16	—	1.02
33852	2.48	1.46	0.87	—	0.63	—	—	—	1/2-13	—	1.02
33853*	2.48	1.46	0.87	0.67	0.63	0.31	1/4-20	3/8	—	0.79	—
33854*	2.48	1.46	0.87	0.75	0.63	0.31	1/4-20	1/2	—	0.79	—
33855	2.91	1.71	1.02	0.75	0.87	0.31	1/4-20	1/2	—	0.79	—
33856	2.91	1.71	1.02	—	0.87	—	—	—	1/2-13	—	1.02

*Steel Insert

Plastic Lobe Knob Metric Elesa Original Design

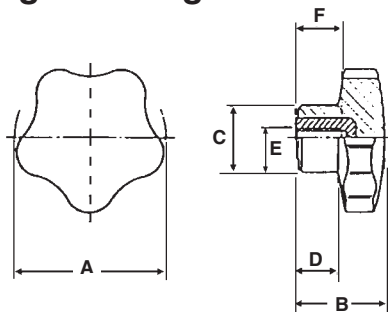

- Material: Duroplast
- Finish: Black Matte
- Insert: Stainless Steel
- Resistant to Solvents, Oils, Greases, and other Chemical Agents

Part Number*	A	B	C	D	E	F
34121	32	23	19	11	M6	12
34122	40	27	21	12	M8	13
34123	50	33	25	14	M10	17
34124	60	37	27	17	M12	20

*Dimensions in millimeters



Plastic Lobe Knob

ELESA Original Design

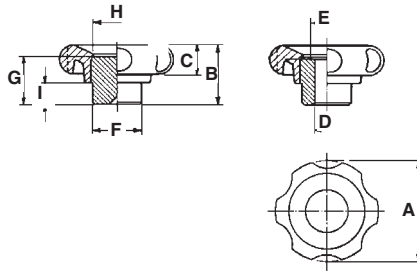

- Material: Black Duroplast
- Finish: Black Bright
- Metal Hub
- Resistant to Solvents, Oils, Greases, and other Chemical Agents

Part Number	A	B	C	D	E	F	G	H	I
33751	2.01	1.14	.51	Blank	—	.79	.83	.71	.39
33752	2.01	1.14	.51	5/16	—	.79	.83	.71	.39
33753	2.01	1.14	.51	5/16-18	—	.79	.83	.71	.39
33755	2.72	1.30	.71	3/8	.71	1.18	.98	1.10	.47
33756	2.72	1.30	.71	3/8-16	.71	1.18	.98	1.10	.47
33758	3.23	1.57	.75	1/2	.71	1.38	1.18	1.34	.59
33759	3.23	1.57	.75	1/2-13	.71	1.38	1.18	1.34	.59
33760	3.90	1.73	.79	Blank	—	1.42	1.34	1.34	.55
33761	3.90	1.73	.79	1/2	.84	1.42	1.34	1.34	.55
33762	3.90	1.73	.79	5/8-11	.84	1.42	1.34	1.34	.55
33763	5.07	1.85	.87	Blank	—	1.57	1.34	1.42	.51
33764	5.07	1.85	.87	1/2	—	1.57	1.34	1.46	.51

Plastic Lobe Knob

ELESA Original Design



- Material: High Impact Strength Technopolymer
- Finish: Black Matte
- Insert: Brass with tapped through hole
- Resistant to Solvents, Oils, Greases, and other Chemical Agents

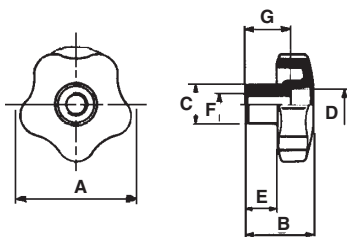

Part Number	A	B	C	D	E	F	G
33831	1.26	0.91	0.59	0.39	0.39	1/4-20	0.47
33832	1.57	1.06	0.67	0.47	0.47	5/16-18	0.71
33833	1.97	1.26	0.75	0.59	0.55	3/8-16	0.79
33834	2.48	1.46	0.87	0.75	0.63	3/8-16	1.02
33835	2.48	1.46	0.87	0.75	0.63	1/2-13	1.02
33836	2.91	1.17	1.02	0.67	0.87	1/2-13	1.02



Plastic Lobe Knob ELESA Original Design

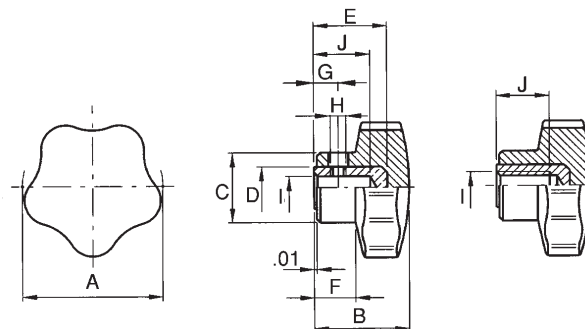

- Material:
Phenolic based
Duroplast
- Insert:
Black oxide steel
or Brass

Part Number	A	B	C	D	E	F	Set Screw		Mounting Hole (I)		J	Wt. lbs.
							G	H	Plain	Tapped		
33884*	1.26	0.91	0.75	—	—	0.43	—	—	—	1/4-20	0.39	0.04
33885*	1.57	1.06	0.83	—	—	0.47	—	—	—	1/4-20	0.47	0.07
33886*	1.57	1.06	0.83	—	—	0.47	—	—	—	5/16-18	0.51	0.06
33887*	1.57	1.06	0.83	0.47	0.67	0.47	0.28	10-32	0.250	—	0.55	0.07
33888*	1.57	1.06	0.83	0.63	0.79	0.47	0.28	10-32	0.312	—	0.63	0.06
33889*	1.97	1.3	0.98	—	—	0.55	—	—	—	5/16-18	0.71	0.11
33890*	1.97	1.3	0.98	—	—	0.55	—	—	—	3/8-16	0.67	0.10
33891*	1.97	1.3	0.98	0.59	0.99	0.55	0.31	10-32	0.312	—	0.79	0.14
33892*	1.97	1.3	0.98	0.63	0.99	0.55	0.31	10-32	0.375	—	0.79	0.13
33893	2.36	1.46	1.06	—	—	0.67	—	—	—	3/8-16	0.67	0.16
33894	2.36	1.46	1.06	—	—	0.67	—	—	—	1/2-13	0.79	0.17
33895	2.36	1.46	1.06	0.67	1.02	0.67	0.35	1/4-20	0.375	—	0.79	0.21
33896	2.36	1.46	1.06	0.79	1.18	0.67	0.35	1/4-20	0.500	—	0.99	0.19
33897	2.75	1.73	1.18	—	—	0.79	—	—	—	1/2-13	0.79	0.26
33898	2.75	1.73	1.18	0.79	1.18	0.79	0.43	1/4-20	0.500	—	0.99	0.27
33899	3.34	2.16	1.37	—	—	1.18	—	—	—	5/8-11	0.86	0.38

*denotes brass insert.

Plastic Lobe Knob ELESA Original Design

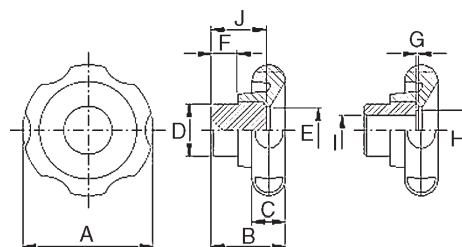

- Materials: Glass reinforced polyamide based technopolymer
- Finish: Black glossy
- Black-oxide steel hub
- Lighter Design
- With plain or tapped hole

1. Not drilled
2. Plain through hole
3. Tapped through hole

Part Number	A	B	C	D	E	F	G	H	Mounting Holes (I)		J	Wt. lbs.
									Plain	Tapped		
34000 ¹	1.97	1.14	0.51	0.79	0.71	0.39	—	—	—	—	0.83	0.16
34001 ²	1.97	1.14	0.51	0.79	0.71	0.39	—	—	0.312	—	0.83	0.14
34002 ²	1.97	1.14	0.51	0.79	0.71	0.39	—	—	—	5/16-18	0.83	0.15
34003 ¹	2.40	1.18	0.53	0.98	0.94	0.43	—	—	—	—	0.91	0.28
34004 ¹	2.76	1.30	0.71	1.18	1.14	0.47	—	—	—	—	0.98	0.42
34005 ²	2.76	1.30	0.71	1.18	1.14	0.47	0.03	0.71	0.375	—	0.98	0.37
34006 ³	2.76	1.30	0.71	1.18	1.14	0.47	0.03	0.71	—	3/8-16	0.98	0.39
34007 ¹	3.15	1.57	0.75	1.38	1.34	0.59	—	—	—	—	1.18	0.66
34008 ²	3.15	1.57	0.75	1.38	1.34	0.59	0.03	0.71	0.500	—	1.18	0.61
34009 ³	3.15	1.57	0.75	1.38	1.34	0.59	0.03	0.71	—	1/2-13	1.18	0.62



Plastic Lobe Knob With Stud ELESA Original Design



- Material: High Impact Strength Technopolymer
- Finish: Black Matte
- Stud: Zinc Plated Steel with Chamfered Flat End
- Resistant to Solvents, Oils, Greases, and other Chemical Agents

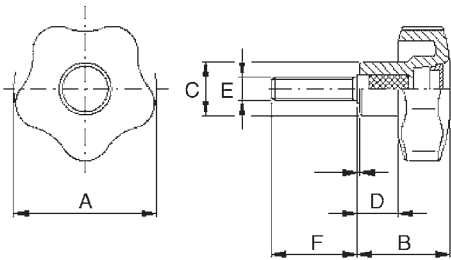

Part Number	A	B	C	D	E	F
33859	0.98	0.75	0.51	0.31	10-32	0.500
33860	0.98	0.75	0.51	0.31	10-32	0.750
33861	1.26	0.91	0.59	0.39	1/4-20	0.500
33862	1.26	0.91	0.59	0.39	1/4-20	0.750
33863	1.26	0.91	0.59	0.39	1/4-20	1.000
33864	1.57	1.06	0.67	0.47	1/4-20	0.500
33865	1.57	1.06	0.67	0.47	1/4-20	1.000
33866	1.57	1.06	0.67	0.47	5/16-18	0.750
33867	1.57	1.06	0.67	0.47	5/16-18	1.000
33868	1.97	1.26	0.75	0.55	5/16-18	1.000
33869	1.97	1.26	0.75	0.55	5/16-18	1.500
33870	1.97	1.26	0.75	0.55	3/8-16	1.000
33871	1.97	1.26	0.75	0.55	3/8-16	1.500
33872	2.48	1.46	0.87	0.63	3/8-16	1.250
33873	2.48	1.46	0.87	0.63	3/8-16	2.000
33874	2.48	1.46	0.87	0.63	1/2-13	1.500
33877	2.91	1.71	1.02	0.87	1/2-13	1.250
33878	2.91	1.71	1.02	0.87	1/2-13	2.000

Plastic Lobe Knob With Stainless Steel Stud ELESA Original Design



- Material: Duroplast
- Finish: Black Matte
- Stud: Stainless Steel
- Resistant to Solvents, Oils, Greases, and other Chemical Agents

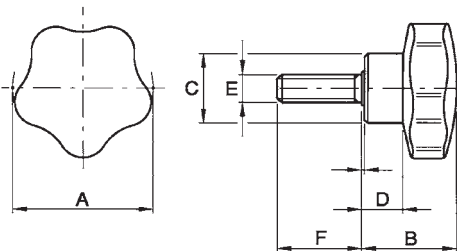

Part Number	A	B	C	D	E	F
34181	1.26	.91	.75	.43	1/4-20	.500
34182	1.26	.91	.75	.43	1/4-20	.750
34183	1.26	.91	.75	.43	1/4-20	1.00
34184	1.57	1.06	.83	.47	5/16-18	.750
34185	1.57	1.06	.83	.47	5/16-18	1.00
34186	1.57	1.06	.83	.47	5/16-18	1.25
34187	1.97	1.30	.98	.55	3/8-16	1.00
34188	1.97	1.30	.98	.55	3/8-16	1.25
34189	1.97	1.30	.98	.55	3/8-16	1.50
34190	1.97	1.30	.98	.55	3/8-16	2.00

Metric

Part Number*	A	B	C	D	E	F
34131	32	23	19	11	M6	16
34132	40	27	21	12	M8	20
34133	40	27	21	12	M8	30
34134	50	33	25	14	M10	20
34135	50	33	25	14	M10	40
34136	60	37	27	17	M12	30

*Dimensions in millimeters



Plastic Fluted Grip Knob ELESA Original Design

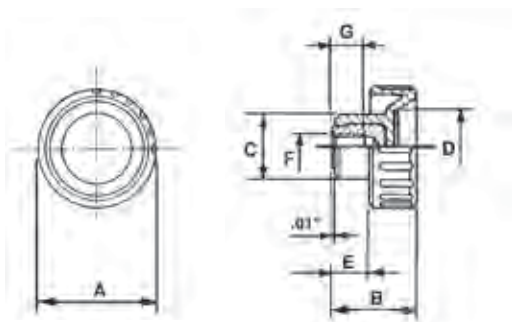

- Material: High Strength Technopolymer
- Finish: Black Matte
- Insert: Brass with tapped blind hole
- Resistant to Solvents, Oils, Greases, and other Chemical Agents

Part Number	A	B	C	D	E	F	G
34200	.79	.63	.47	.43	.24	8-32	.24
34201	.79	.63	.47	.43	.24	10-32	.24
34202	.98	.75	.63	.59	.31	10-32	.39
34203	.98	.75	.63	.59	.31	1/4-20	.31
34204	1.26	.87	.67	.83	.35	1/4-20	.39
34205	1.26	.87	.67	.83	.35	5/16-18	.39

Metric

Part Number*	A	B	C	D	E	F	G
34260	16	13	11	9	5	M4	6
34261	20	16	12	11	6	M5	6
34262	25	19	16	15	8	M6	8
34263	32	22	17	21	9	M8	10

*Dimensions in millimeters

Plastic Fluted Grip Knob With Stud ELESA Original Design

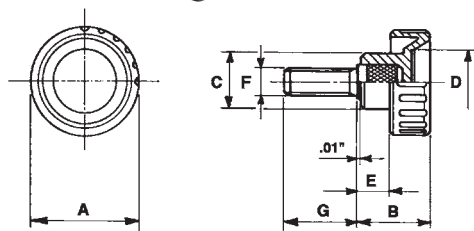

- Material: High Impact Strength Technopolymer
- Finish: Black Matte
- Zinc-Plated Steel Stud With Chamfered Flat End
- Resistant to Solvents, Oils, Greases, and other Chemical Agents

Part Number	A	B	C	D	E	F	G
34210	0.63	0.51	0.43	0.35	0.2	8-32	0.375
34211	0.63	0.51	0.43	0.35	0.2	8-32	0.500
34212	0.79	0.63	0.47	0.43	0.24	8-32	0.500
34213	0.79	0.63	0.47	0.43	0.24	8-32	0.750
34214	0.79	0.63	0.47	0.43	0.24	10-32	0.500
34215	0.79	0.63	0.47	0.43	0.24	10-32	0.750
34216	0.98	0.75	0.63	0.59	0.31	1/4-20	0.500
34217	0.98	0.75	0.63	0.59	0.31	1/4-20	0.750
34218	0.98	0.75	0.63	0.59	0.31	1/4-20	1.000
34219	1.26	0.87	0.67	0.83	0.35	5/16-18	0.750
34220	1.26	0.87	0.67	0.83	0.35	5/16-18	1.000
34221	1.57	1.06	0.75	0.98	0.51	3/8-16	1.000
34222	1.97	1.12	0.87	1.22	0.53	3/8-16	1.000

Metric

Part Number*	A	B	C	D	E	F	G
34250	16	13	11	9	5	M4	10
34251	16	13	11	9	5	M5	10
34252	20	16	12	11	6	M5	16
34253	20	16	12	11	6	M6	16
34254	25	19	16	15	8	M6	16
34255	25	19	16	15	8	M8	16
34256	32	22	17	21	9	M8	16
34257	32	22	17	21	9	M10	20

*Dimensions in millimeters



Knurled Knob ELESA Original Design

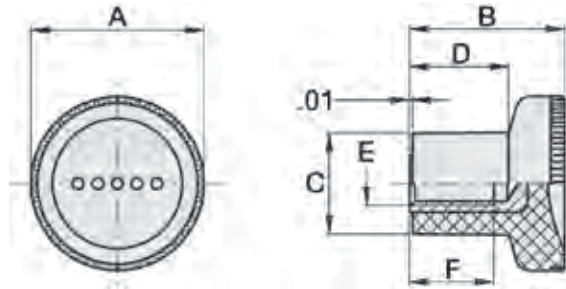

- Material: High Strength Technopolymer
- Finish: Gray/Black Matte
- Insert: Brass With Tapped Blind Hole
- Resistant to Solvents, Oils, Greases, and other Chemical Agents
- Concave surface makes gripping easier.

Part Number	A	B	C	D	E	F
34490	0.83	0.71	0.49	0.41	10-32	0.39
34491	0.98	0.89	0.57	0.55	1/4-20	0.47
34492	1.22	1.06	0.73	0.67	5/16-18	0.63

Knurled Knob With Stud ELESA Original Design

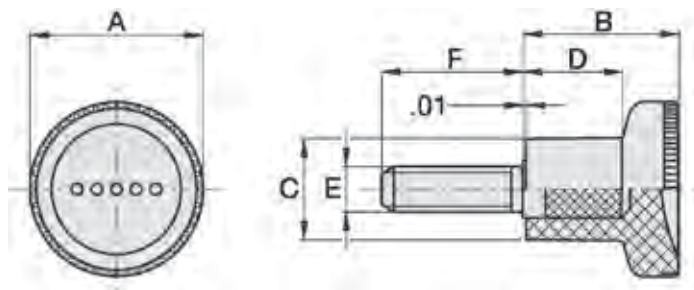

- Material: High Strength Technopolymer
- Finish: Gray/Black Matte
- Stud: Zinc Plated Threaded Steel With Chamfered End
- Resistant to Solvents, Oils, Greases, and other Chemical Agents
- Concave surface makes gripping easier.

Part Number	A	B	C	D	E	F
34493	.83	.71	.49	.41	10-32	.750
34494	.98	.89	.57	.55	1/4-20	.750
34495	1.22	1.06	.73	.67	5/16-18	.750



Plastic Latch Type Lobe Knob ELESA Original Design

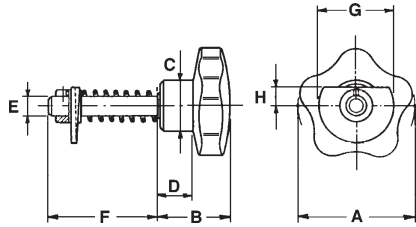

- Material: Black Duroplast
- Finish: Black Bright
- Stud: Zinc Plated Steel
- Resistant to Solvents, Oils, Greases, and other Chemical Agents
- Available in Stainless Steel with left or right swing style

Part Number	A	B	C	D	E	F	G	H	Swing Style
33881	1.97	1.30	.98	.55	.47	1.81	1.77	.47	Left
33882	2.36	1.46	1.06	.67	.47	1.81	1.77	.47	Right

Plastic Knurled Grip Knob ELESA Original Design

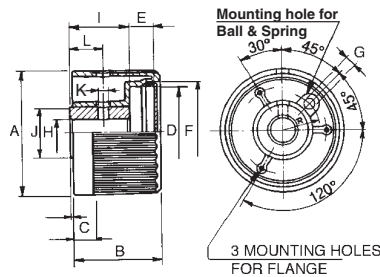

- Material: Glass-Fibre Reinforced Technopolymer
- Finish: Black Bright
- Black Oxide Steel Insert
- Resistant to Solvents, Oils, Greases, and other Chemical Agents

Part Number	A	B	C	D	E	F	G	H	I	J	K	L
33741	1.89	1.38	.31	1.26	.39	1.34	.13	.375	.87	.87	.16	.55
33742	2.05	1.54	.35	1.46	.51	1.54	.17	.500	.87	.87	.16	.55
33743	2.28	1.61	.39	1.65	.43	1.73	.20	.500	1.06	1.02	.20	.63
33744	2.48	1.73	.43	1.89	.39	1.97	.24	.500	1.18	1.02	.20	.63

KNOBS



Plastic T-Handle

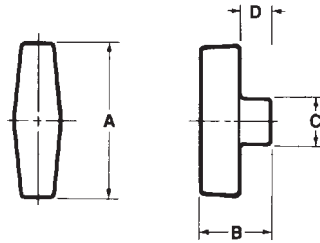

- Material: Polypropylene
- Finish: Tumble
- Insert: Metal
- Also Available With Stud
- Ideal For High Torque Applications
- Textured Grip

Part Number	A	B	C	D	Insert
32126	2 1/2	1 1/4	3/4	5/8	5/16-18 x 3/4

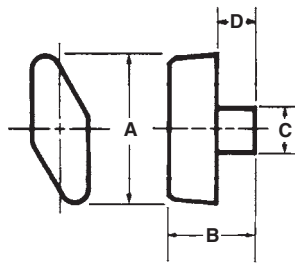

Part Number	A	B	C	D	Insert
32121	2	1 1/8	5/8	1/2	5/16-18 x 5/8

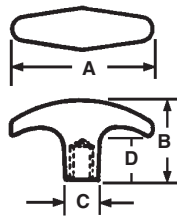

- Material: Plastic
- Finish: Tumble
- For heavy-duty clamping and push/pull applications; latch release with pull cables or rods; also for cabinet doors, access panel latches, etc.

Part Number	Insert Thread and Depth	A	B	C	D
32115	5/16-18 x 7/16	2 1/4	1 1/4	9/16	11/16
32116	1/4-20 x 7/16	2 1/4	1 1/4	9/16	11/16

Plastic T-Handle ELESA Original Design

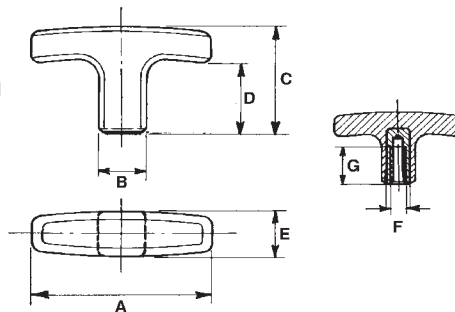

- Material: Glass-Fibre Reinforced Technopolymer
- Finish: Black Matte
- Insert: Brass With Tapped Blind Hole
- Resistant to Solvents, Oils, Greases, and other Chemical Agents

Part Number	A	B	C	D	E	F	G	Ft.* lbs.
33711	1.57	0.51	1.18	0.79	0.51	1/4-20	0.63	560
33712	2.17	0.55	1.3	0.87	0.55	1/4-20	0.71	739
33713	2.64	0.63	1.46	0.98	0.63	5/16-18	0.79	1,008
33714	3.15	0.79	1.61	1.02	0.79	3/8-16	0.79	1,568
33715	3.66	0.83	1.77	1.12	0.83	1/2-13	0.79	1,795

*Max. Tensile strength / Pull Force



Plastic Tapered Knob

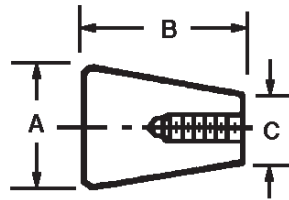

- Tapered shanks, enlarged heads provide good finger clearance and excellent grasp for pulling
- Popular Applications: push-pull rods, palm switch knobs, palm grasp knobs (for portable power tools), push buttons, drawer pulls, etc.

- Material: Plastic
- Finish: Tumble
- Insert: Brass
- 3D Solid Models are available in multiple formats from www.jergensinc.com

Part Number	A	B	C	Insert Thread and Depth
32213	1	1 1/4	1/2	1/4-20 x 7/16
32214	1	1 1/4	1/2	5/16-18 x 7/16

Plastic Lift Knob

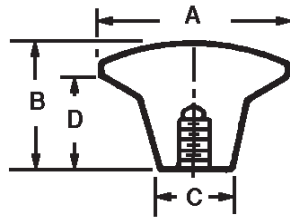

- Material: Plastic
- Finish: Tumble
- Insert: Brass
- 3D Solid Models are available in multiple formats from www.jergensinc.com

Part Number	A	B	C	D	Insert Thread and Depth
32217	1 3/8	7/8	5/8	5/8	1/4-20 x 7/16

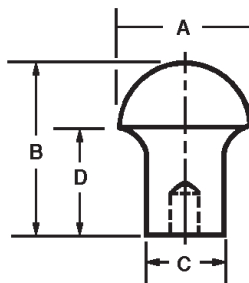

Part Number	A	B	C	D	Insert Thread and Depth
32215	1	1 3/16	9/16	11/16	10-32 x 5/16
32216	1	1 3/16	9/16	11/16	1/4-20 x 7/16

Jergens offers 3D models

for all handles, knobs and handwheels at www.jergensinc.com



Plastic Oval Tapered Knob



- Material: Polypropylene
- Finish: Tumble
- For shift levers, control levers, push/pull rods on machine tools, lawn and garden equipment, jigs and fixtures, and for finger tip levers or lid knobs.
- Available with either brass insert, tapped plastic thread, or untapped through hole.
- Sand and Buff Finish available upon request
- 3D Solid Models are available in multiple formats from www.jergensinc.com

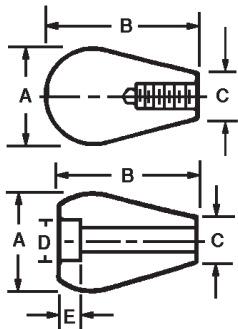

Part Number	A	B	C	D	E	Hole Diameter
32211*	1 3/16	1 7/8	9/16	—	—	5/16-18 x 3/4
32218**	1 3/16	1 7/8	9/16	—	—	1/4-20 x 7/16 .380/.385
32212	1 3/16	1 3/4	9/16	9/16	5/16	through hole (untapped) .313/.318
32219	1 3/16	1 3/4	9/16	9/16	5/16	through hole (untapped)

*Tapped plastic threads
**Brass insert

Soft Touch Oval Tapered Knob



- Material: Soft Touch Plastic
- Finish: "Soft Feel" Black Matte
- Insert: Brass
- Cushioned vinyl covering helps to dampen vibrations
- Also available in red, blue, yellow, and green (250 piece minimum)

This Oval Tapered Knob has the original soft touch material that helps in gripping. It is designed with an enlarged head and tapered shaft for maximum push, pull, and turning.

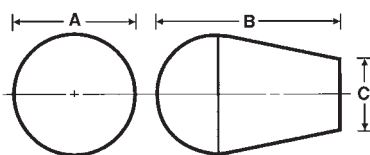

Part Number	A	B	C	Hole Diameter
32150	1 5/8	2 1/2	7/8	5/16-18 x 5/8
32151	1 5/8	2 1/2	7/8	5/16
32152	1 5/8	2 1/2	7/8	3/8-16 x 5/8
32153	1 5/8	2 1/2	7/8	3/8

WARNING - Cancer and Reproductive Harm - www.P65Warnings.ca.gov



Soft Touch Tapered Knob



- Material: Soft Touch Plastic
- Finish: Black Matte
- Insert: Brass
- Cushioned vinyl covering helps to dampen vibrations
- Also available in red, blue, yellow, and green (250 piece minimum)

This Oval Tapered Knob has the original soft touch material that helps in gripping. It is designed with an enlarged head and tapered shaft for maximum push, pull, and turning.

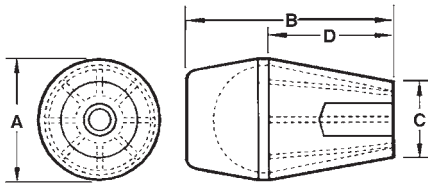

Part Number	A	B	C	D	Hole Diameter
32160	1 1/2	2 1/2	15/16	1 1/2	1/4-20 x 5/8
32161	1 1/2	2 1/2	15/16	1 1/2	5/16-18 x 3/4
32162	1 1/2	2 1/2	15/16	1 1/2	3/8-16 x 5/8

Soft Touch Tapered Knob



- Material: Soft Touch Plastic
- Finish: Black Matte
- Insert: Brass
- Cushioned vinyl covering helps to dampen vibrations
- Also available in red, blue, yellow, and green (250 piece minimum)
- A standard 1" stud is available, other lengths available upon request.

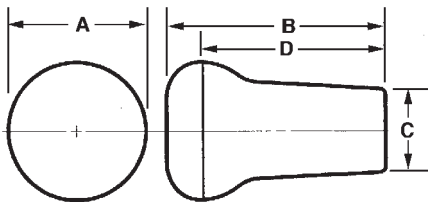

Part Number	A	B	C	D	Hole Diameter
32180	1 5/8	2 1/2	7/8	2 1/8	1/4-20 x 5/8
32181*	1 5/8	2 1/2	7/8	2 1/8	1/4 x 1
32182	1 5/8	2 1/2	7/8	2 1/8	5/16-18 x 5/8
32183*	1 5/8	2 1/2	7/8	2 1/8	5/16 x 1
32184*	1 5/8	2 1/2	7/8	2 1/8	3/8 x 1
32170	1 3/8	2 1/8	13/16	1 3/4	5/16-18 x 5/8
32171	1 3/8	2 1/8	13/16	1 3/4	3/8-16 x 5/8
32172*	1 3/8	2 1/8	13/16	1 3/4	3/8 x 1
32173	1 3/8	2 1/8	13/16	1 3/4	1/2-13 x 5/8
32174*	1 3/8	2 1/8	13/16	1 3/4	1/2 x 1

*Cored Hole

WARNING - Cancer and Reproductive Harm - www.P65Warnings.ca.gov



Plastic Push/Pull Knob



- Material: Thermoplastic
- Finish: Matte
- Insert: Brass
- Also available with stud

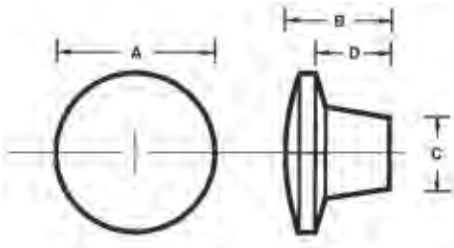

Part Number	A	B	C	D	Insert
32225	1 3/8	7/8	5/8	5/8	8-32
32226	1 3/8	7/8	5/8	5/8	10-32
32227	1 3/8	7/8	5/8	5/8	1/4-20
32228	1 3/8	7/8	5/8	5/8	5/16-18
32229	1 3/8	7/8	5/8	5/8	3/8-16

Plastic Push/Pull Knob

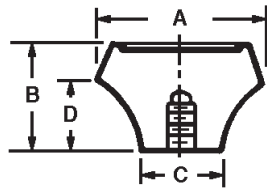

- Material: Plastic
- Finish: Tumbled
- Insert: Brass
- 3D Solid Models are available in multiple formats from www.jergensinc.com

Part Number	A	B	C	D	Insert Thread and Depth
32220	1	11/16	1/2	7/16	8-32 x 5/16
32221	1	11/16	1/2	7/16	10-32 x 5/16
32222	1	11/16	1/2	7/16	1/4-20 x 7/16
32223	1	15/16	9/16	11/16	10-32 x 7/16
32224	1	15/16	9/16	11/16	1/4-20 x 7/16

Plastic Three-Spoked Knob ELESA Original Design

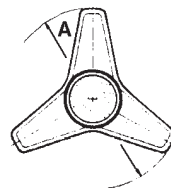
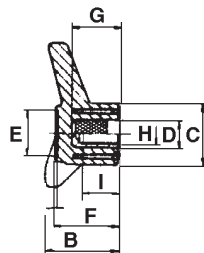

- Material: Glass-Fibre Reinforced Technopolymer
- Finish: Black Matte
- Brass Insert with tapped blind hole
- Insert: Brass or Steel with plain blind hole
- Resistant to Solvents, Oils, Greases, and other Chemical Agents

Part Number	A	B	C	D	E	F	G	H	I	Insert
33731	2.48	1.10	1.02	—	.70	.98	—	5/16-18	.62	Brass
33732	2.48	1.10	1.02	.59	.70	.98	.87	5/16	.62	Steel
33733	3.14	1.37	1.25	—	.82	1.18	—	3/8-16	.67	Brass
33734	3.14	1.37	1.25	.59	.82	1.18	.98	3/8	.79	Steel
33735	3.93	1.65	1.41	—	.98	1.41	—	1/2-13	.79	Brass
33736	3.93	1.65	1.41	.94	.98	1.41	1.29	1/2	.98	Steel



Stainless Steel Palm Grips

Inch



- Material: Stainless Steel
- Finish: ground and polished

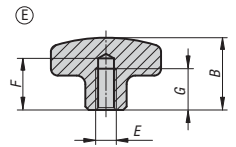
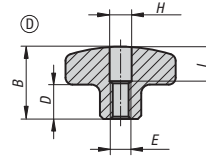
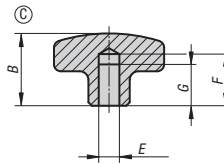
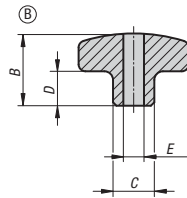
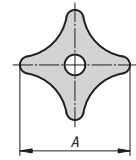

Style	Part No.	A	B	C	D	E	F	G	H	I
B	40360	1.26	0.79	0.47	0.39	0.250	-	-	-	-
B	40361	1.57	0.98	0.55	0.51	0.312	-	-	-	-
B	40362	1.97	1.26	0.71	0.67	0.375	-	-	-	-
B	40363	2.48	1.57	0.79	0.93	0.500	-	-	-	-
C	40364	1.26	0.83	0.47	0.39	0.250	0.59	0.47	-	-
C	40365	1.57	1.02	0.55	0.51	0.312	0.71	0.59	-	-
C	40366	1.97	1.34	0.71	0.67	0.375	0.83	0.71	-	-
C	40367	2.48	1.65	0.79	0.83	0.500	0.98	0.87	-	-
D	40368	1.26	0.79	0.47	0.39	1/4-20	-	-	0.25	0.39
D	40369	1.57	0.98	0.55	0.51	5/16-18	-	-	0.33	0.47
D	40370	1.97	1.26	0.71	0.67	3/8-16	-	-	0.41	0.63
D	40371	2.44	1.57	0.79	0.83	1/2-13	-	-	0.51	0.79
E	40372	1.26	0.83	0.47	0.39	1/4-20	0.59	0.47	-	-
E	40373	1.57	1.02	0.55	0.51	5/16-18	0.71	0.59	-	-
E	40374	1.97	1.34	0.71	0.67	3/8-16	0.83	0.71	-	-
E	40375	2.44	1.65	0.79	0.83	1/2-13	0.98	0.87	-	-

Stainless Steel Palm Grips

Metric

Style	Part No.	A	B	C	D	E	F	G	H	I
B	40376	32	20	12	10	6	-	-	-	-
B	40377	40	25	14	13	8	-	-	-	-
B	40378	50	32	18	17	10	-	-	-	-
B	40379	63	40	20	21	12	-	-	-	-
C	40380	32	21	12	10	6	15	12	-	-
C	40381	40	26	14	13	8	18	15	-	-
C	40382	50	34	18	17	10	21	18	-	-
C	40383	63	42	20	21	12	25	22	-	-
D	40384	32	20	12	10	M6	-	-	6.4	10
D	40385	40	25	14	13	M8	-	-	8.4	12
D	40386	50	32	18	17	M10	-	-	10.5	16
D	40387	63	40	20	21	M12	-	-	13	20
E	40388	32	21	12	10	M6	15	12	-	-
E	40389	40	26	14	13	M8	18	15	-	-
E	40390	50	34	18	17	M10	21	18	-	-
E	40391	63	42	20	21	M12	25	22	-	-



Aluminum Palm Grips

Inch



- Material: Aluminum
- Finish: natural finish, tumbled
- Tumbled finish is shiny and slightly dimpled

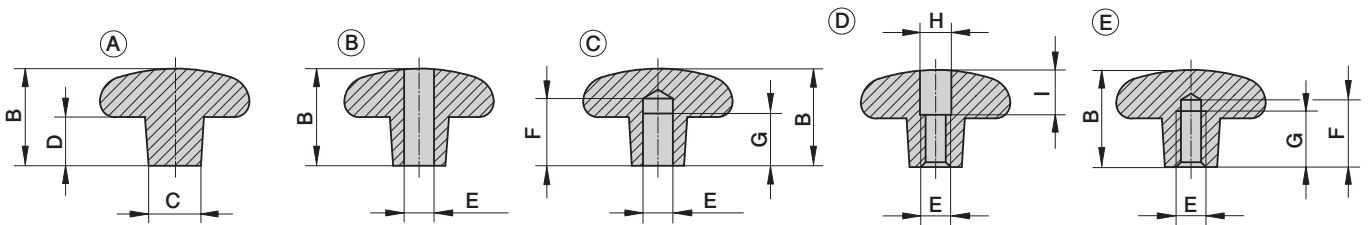
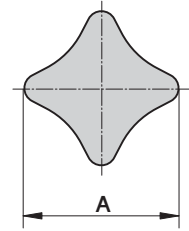

Style	Part No. Tumbled	Part No. Polished	A	B	C	D	E	F	G	H	I
A	40309	-	40	26	14	14	-	-	-	-	-
A	40310	-	50	34	18	20	-	-	-	-	-
A	40311	-	63	42	25	25	-	-	-	-	-
A	40312	-	80	52	25	30	-	-	-	-	-
B	40313	40329	40	25	14	14	8	-	-	-	-
B	40314	40330	50	32	18	20	10	-	-	-	-
B	40315	40331	63	40	25	25	12	-	-	-	-
B	40316	40332	80	50	25	30	16	-	-	-	-
C	40317	40333	40	26	14	14	8	18	15	-	-
C	40318	40334	50	34	18	20	10	21	18	-	-
C	40319	40335	63	42	25	25	12	25	22	-	-
C	40320	40336	80	52	25	30	16	32	28	-	-
D	40321	40337	40	25	14	14	M8	-	-	8.4	12
D	40322	40338	50	32	18	20	M10	-	-	10.5	16
D	40323	40339	63	40	25	25	M12	-	-	13	20
D	40324	40340	80	50	25	30	M16	-	-	17	30
E	40325	40341	40	26	14	14	M8	18	15	-	-
E	40326	40342	50	34	18	18	M10	21	18	-	-
E	40327	40343	63	42	25	25	M12	25	22	-	-
E	40328	40344	80	52	25	25	M16	32	28	-	-

KNOBS



Aluminum Star Nuts Metric



- Material: Aluminum
- Finish: natural finish, tumbled
- Tumbled finish is shiny and slightly dimpled

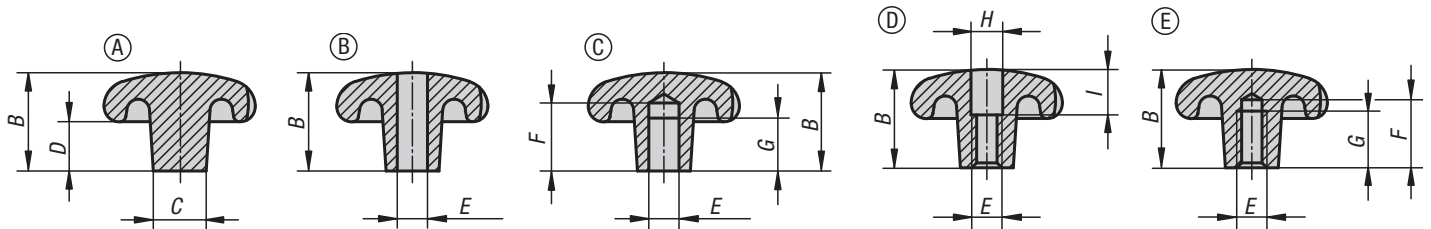
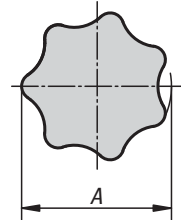

Style	Part No. Tumbled	Part No. Polished	A	B	C	D	E	F	G	H	I
A	40785	-	40	26	14	13	-	-	-	-	-
A	40786	-	50	34	18	17	-	-	-	-	-
A	40787	-	63	42	20	21	-	-	-	-	-
A	40788	-	80	52	25	25	-	-	-	-	-
B	40789	40805	40	25	14	13	8	-	-	-	-
B	40790	40806	50	32	18	17	10	-	-	-	-
B	40791	40807	63	40	20	21	12	-	-	-	-
B	40792	40808	80	50	25	25	16	-	-	-	-
C	40793	40809	40	26	14	13	8	18	15	-	-
C	40794	40810	50	34	18	17	10	21	18	-	-
C	40795	40811	63	42	20	21	12	25	22	-	-
C	40796	40812	80	52	25	25	16	32	28	-	-
D	40797	40813	40	25	14	13	M8	-	-	8.4	12
D	40798	40814	50	32	18	17	M10	-	-	10.5	16
D	40799	40815	63	40	20	21	M12	-	-	13	20
D	40800	40816	80	50	25	25	M16	-	-	17	30
E	40801	40817	40	26	14	13	M8	18	15	-	-
E	40802	40818	50	34	18	17	M10	21	18	-	-
E	40803	40819	63	42	20	21	M12	25	22	-	-
E	40804	40820	80	52	25	25	M16	32	28	-	-



Stainless Steel Star Grips

Inch

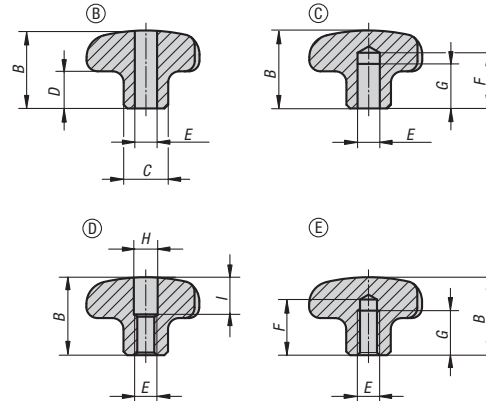
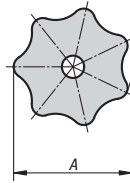

- Material: Stainless steel
- Finish: ground and polished
- Highly polished finish looks great

Style	Part No.	A	B	C	D	E	F	G	H	I
B	40821	1.26	0.79	0.47	0.39	0.250	-	-	-	-
B	40822	1.57	0.98	0.55	0.51	0.312	-	-	-	-
B	40823	1.97	1.26	0.71	0.67	0.375	-	-	-	-
B	40824	2.48	1.57	0.79	0.83	0.500	-	-	-	-
C	40825	1.26	0.83	0.47	0.39	0.250	0.59	0.47	-	-
C	40826	1.57	1.02	0.55	0.51	0.312	0.71	0.59	-	-
C	40827	1.97	1.34	0.71	0.67	0.375	0.83	0.71	-	-
C	40828	2.48	1.65	0.79	0.83	0.500	0.98	0.87	-	-
D	40829	1.26	0.79	0.47	0.39	1/4-20	-	-	0.25	0.39
D	40830	1.57	0.98	0.55	0.51	5/16-18	-	-	0.33	0.47
D	40831	1.97	1.26	0.71	0.67	3/8-16	-	-	0.41	0.63
D	40832	2.48	1.57	0.79	0.83	1/2-13	-	-	0.51	0.79
E	40833	1.26	0.83	0.47	0.39	1/4-20	0.59	0.47	-	-
E	40834	1.57	1.02	0.55	0.51	5/16-18	0.71	0.59	-	-
E	40835	1.97	1.34	0.71	0.67	3/8-16	0.83	0.71	-	-
E	40836	2.48	1.65	0.79	0.83	1/2-13	0.98	0.87	-	-

Stainless Steel Star Grips

Metric

Style	Part No.	A	B	C	D	E	F	G	H	I
B	40837	32	20	12	10	6	-	-	-	-
B	40838	40	25	14	13	8	-	-	-	-
B	40839	50	32	18	17	10	-	-	-	-
B	40840	63	40	20	21	12	-	-	-	-
C	40841	32	21	12	10	6	15	12	-	-
C	40842	40	26	14	13	8	18	15	-	-
C	40843	50	34	18	17	10	21	18	-	-
C	40844	63	42	20	21	12	25	22	-	-
D	40845	32	20	12	10	M6	-	-	6.4	10
D	40846	40	25	14	13	M8	-	-	8.4	12
D	40847	50	32	18	17	M10	-	-	10.5	16
D	40848	63	40	20	21	M12	-	-	13	20
E	40849	32	21	12	10	M6	15	12	-	-
E	40850	40	26	14	13	M8	18	15	-	-
E	40851	50	34	18	17	M10	21	18	-	-
E	40852	63	42	20	21	M12	25	22	-	-



Wing Nuts Inch

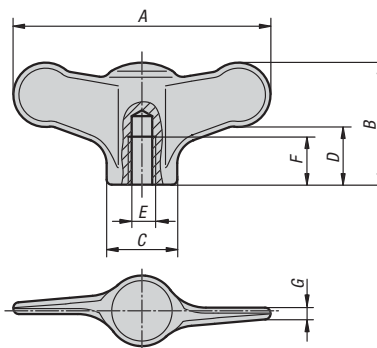

Blasted

- Material: Stainless steel
- Finish: Blasted
- Wings are offset for comfortable, ergonomic grip
- Coarse, blasted finish delivers an economical option for applications where appearance is less important.

Ground and Polished

- Material: Stainless steel
- Finish: ground and polished
- Wings are offset for comfortable, ergonomic grip
- Polished to a shiny, smooth finish for a high quality look and feel.

Ground & Polished Part No.	Blasted Part No.	A	B	C	D	E	F	G
40853	40861	1.50	0.71	0.41	0.34	8-32	0.35	0.067
40854	40862	1.50	0.71	0.41	0.34	10-32	0.35	0.067
40855	40863	1.50	0.71	0.41	0.34	1/4-20	0.35	0.067
40856	40864	1.97	0.94	0.55	0.45	10-24	0.39	0.091
40857	40865	1.97	0.94	0.55	0.45	10-32	0.47	0.091
40858	40866	1.97	0.94	0.55	0.45	1/4-20	0.39	0.091
40859	40867	2.95	1.39	0.83	0.65	5/16-18	0.55	0.134
40860	40868	2.95	1.39	0.83	0.65	3/8-16	0.55	0.134

Wing Nuts Metric

Ground & Polished Part No.	Blasted Part No.	A	B	C	D	E	F	G
40869	40876	38	18	10.5	8.5	M4	9	1.7
40870	40877	38	18	10.5	8.5	M5	9	1.7
40871	40878	38	18	10.5	8.5	M6	9	1.7
40872	40879	50	24	14	11.5	M5	12	2.3
40873	40880	50	24	14	11.5	M6	12	2.3
40874	40881	75	35	21	16.5	M8	15	3.4
40875	40882	75	35	21	16.5	M10	15	3.4



Mushroom Knobs Inch

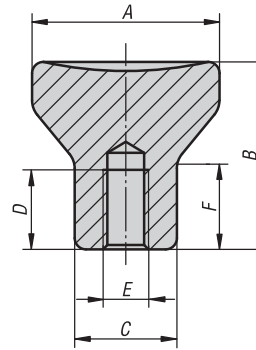

- Material: Stainless steel
- Finish: Electrolytic-polish
- Mushroom knob with polished surface

Part No.	E	A	C	B	F	D
40883	2-56	0.55	0.32	0.55	0.26	0.16
40884	6-32	0.71	0.39	0.71	0.34	0.30
40885	8-32	0.83	0.47	0.83	0.39	0.39
40886	10-24	0.83	0.47	0.83	0.39	0.49
40887	10-32	0.83	0.47	0.83	0.39	0.49
40888	1/4-20	0.98	0.55	0.98	0.47	0.47
40889	5/16-18	1.30	0.71	1.30	0.63	0.63
40890	3/8-16	1.57	0.94	1.57	0.41	0.79

Mushroom Knobs Metric

Part No.	E	A	C	B	F	D
40891	M2	14	8	14	6.7	4
40892	M3	18	10	18	8.6	7.5
40893	M4	21	12	21	10	10
40894	M5	21	12	21	10	12.5
40895	M6	25	14	25	12	12
40896	M8	33	18	33	16	16
40897	M10	40	24	40	18.7	20



Knurled Thumb Screw Stainless Steel, Inch

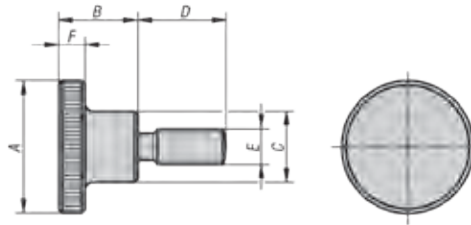

Stainless Steel

- Material: Stainless steel
- Finish: Natural
- Knurled Head
- Note: The knurled thumb screw is supplied with no thread undercut

Part No. SS	A	B	C	D	E	F
41838	0.63	0.37	0.32	0.39	8-32	0.14
41839	0.63	0.37	0.32	0.63	8-32	0.14
41840	0.63	0.37	0.32	0.79	8-32	0.14
41841	0.79	0.45	0.39	0.39	10-24	4.00
41842	0.79	0.45	0.39	0.63	10-24	4.00
41843	0.79	0.45	0.39	0.79	10-24	4.00
41844	0.94	0.59	0.47	0.39	1/4-20	0.20
41845	0.94	0.59	0.47	0.63	1/4-20	0.20
41846	0.94	0.59	0.47	0.79	1/4-20	0.20
41847	0.94	0.59	0.47	0.98	1/4-20	0.20
41848	1.18	0.71	0.63	0.63	5/16-18	0.24
41849	1.18	0.71	0.63	0.79	5/16-18	0.24
41850	1.18	0.71	0.63	0.98	5/16-18	0.24
41851	1.42	0.91	0.79	0.79	3/8-16	0.32
41852	1.42	0.91	0.79	0.79	3/8-16	0.32

Knurled Thumb Screw Stainless Steel & Steel, Metric

Free-Cutting Steel

- Material: steel
- Finish: black oxide
- Knurled Head
- Note: The knurled thumb screw is supplied with no thread undercut

Part No. Steel	Part No. SS	A	B	C	D	E	F
41853	41871	16	9.5	8	10	M4	3.5
41854	41872	16	9.5	8	16	M4	3.5
41855	41873	16	9.5	8	20	M4	3.5
41856	41874	20	11.5	10	10	M5	4
41857	41875	20	11.5	10	16	M5	4
41858	41876	20	11.5	10	20	M5	4
41859	41877	24	15	12	10	M6	5
41860	41878	24	15	12	16	M6	5
41861	41879	24	15	12	20	M6	5
41862	41880	24	15	12	25	M6	5
41863	41881	30	18	16	16	M8	6
41864	41882	30	18	16	20	M8	6
41865	41883	30	18	16	25	M8	6
41866	41884	30	18	16	30	M8	6
41867	41885	36	23	20	20	M10	8
41868	41886	36	23	20	25	M10	8
41869	41887	36	23	20	30	M10	8
41870	41888	36	23	20	40	M10	8

We Are Jergens

WORKHOLDING SOLUTIONS

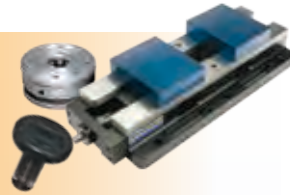

SUPPORT, LOCATE AND HOLD:

From standard components to vises and quick change fixture systems like Ball Lock®, ZPS and Fixture-Pro® Multi-Axis.

SPECIALTY FASTENERS



FASTEN, STRENGTHEN AND SECURE:

From threaded inserts and toggle clamps to Kwik-Lok® Pins.

LIFTING SOLUTIONS



LIFT, TURN AND TRACK:

From chain sling and eye bolts to hoist rings and our proprietary Lift-Check™ hoist rings.

We got our start back in 1942, manufacturing tooling components to help American manufacturers operate quickly and more efficiently. “The Standard Components with the Highest Standards.” This founding philosophy put Jergens on the forefront of the “lean manufacturing” movement before anyone even thought to put those two words together.

In the years since, Jergens has structured its offering to advance the cause of leaner manufacturing, adding products and engineered solutions for an integrated approach to “Manufacturing Efficiency.”

You can find Jergens products just about anywhere in the manufacturing environment.

Jergens
MANUFACTURING EFFICIENCY

Jergens®

MANUFACTURING EFFICIENCY

WORLD HEADQUARTERS

15700 S. WATERLOO ROAD
CLEVELAND, OH 44110-3898

 866.KWIK.LOK (594-5565)

 JERGENSINC.COM/SPECIALTY-FASTENERS

 FASTENERS@JERGENSINC.COM

DISTRIBUTED BY:



WORKHOLDING SOLUTIONS



SPECIALTY FASTENERS



LIFTING SOLUTIONS

©2020 JERGENS, INC. | IMG0220

