

Alcoa
Fastening
Systems



DOUBLE SLOTTED TURRET NUTS

FULLY CERTIFIED BY *Network Rail*



DOUBLE SLOTTED TURRET NUTS

Class (CL8), Dual-lock self lock nut, zinc passivated (Chrome 6 free) meeting the designated standards NFE25411 & BS EN ISO 2320:1998 (partially replaces BS 4929-1:1973)

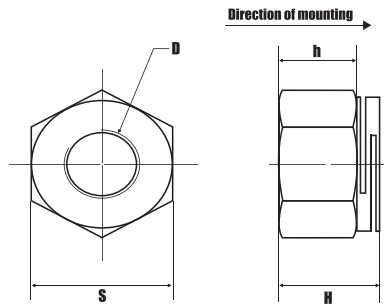

Industrial examples: wherever there is continual or intermittent vibration which could cause fastener loosening:

Railway Industry

- Electrical connection to tracks and overhead
- Electrical lines to connection boxes
- Fasten wheels to the wagons
- Fasten rails to cement sleepers
- Stretcher bars

Other Industrial Applications

- Off-shore platforms (Anti-corrosion)
- Mining conveyors
- Cranes
- Agricultural equipment
- Compressors

H&C code	D	Pitch	S	H	h	SNEP code	Network Rail PADS Number	Box Quantity
				MAX				
1687M45	M4	0.70	7	5.6	3	DAH M4X070 CL.8	-	10000
1687M47	M5	0.80	8	6.5	3.7	DAH M5X080 CL.8	-	8000
1687M49	M6	1.00	10	8	4.5	DAH M6X100 CL.8	003/96079	4000
1687M54	M8	1.25	13	10	5.5	DAH M8X125 CL.8	003/96080	2000
1687M56	M10	1.50	16	12.5	6.5	DAH M10X150 CL.8	003/96081	1000
1687M58	M12	1.75	18	15	8.5	DAH M12X175 CL.8	003/96082	500
1687M60	M14	2.00	21	17.5	10	DAH M14X200 CL.8	003/96083	400
1687M62	M16	2.00	24	18.7	12	DAH M16X200 CL.8	003/96084	250
1687M63	M18	2.50	27	22	14	DAH M18X250 CL.8	003/96085	150
1687M64	M20	2.50	30	24	16	DAH M20X250 CL.8	003/96086	100
1687M65	M22	2.50	34	27	19	DAH M22X250 CL.8	003/96087	50
1687M66	M24	3.00	36	24	14	DAH M24X300 CL.8	003/96088	50
1687M69	M30	3.50	46	37	24	DAH M30X350 CL.8	-	30

European Rail Standard Certified "SNCF" - CF 00-040 FP n° 6

NETWORK RAIL CERTIFIED (CERTIFICATE NUMBER PA05/03451, 19/12/07)

DIMENSIONS :

According to NFE 25 411

THREAD:

Profile ISO - according to ISO 965-2 Quality 6H

MECHANICAL CHARACTERISTICS :

According to NF EN ISO 2320

Conforms to European RoHS Directive



Manufactured within the EU by Alcoa Fastening Systems, ISO 9001V2000 - EN9100 - ISO 14001

Alcoa
Fastening
Systems

